



**EXPERION PKS**

**RELEASE 516**

# Serial Interface Module Implementation Guide

EPDOC-X123-en-516A

August 2020

---

# Disclaimer

This document contains Honeywell proprietary information. Information contained herein is to be used solely for the purpose submitted, and no part of this document or its contents shall be reproduced, published, or disclosed to a third party without the express permission of Honeywell International Sàrl.

While this information is presented in good faith and believed to be accurate, Honeywell disclaims the implied warranties of merchantability and fitness for a purpose and makes no express warranties except as may be stated in its written agreement with and for its customer.

In no event is Honeywell liable to anyone for any direct, special, or consequential damages. The information and specifications in this document are subject to change without notice.

Copyright 2020 - Honeywell International Sàrl

---

<b>Contents</b> .....	<b>3</b>
<b>Chapter 1 - About This Document</b> .....	<b>1</b>
<b>Chapter 2 - Serial Interface Module Purpose</b> .....	<b>2</b>
2.1 About the SIM .....	2
2.2 Function block support for serial interface .....	4
2.3 SIM processing characteristics .....	5
<b>Chapter 3 - SIM Planning and Design</b> .....	<b>7</b>
3.1 General Planning References .....	7
3.2 General MODBUS Protocol References .....	7
3.3 Identifying Serial Interface Module Components .....	7
3.4 SIM implementation considerations and restrictions .....	8
<b>Chapter 4 - SIM Installation and Upgrades</b> .....	<b>10</b>
4.1 SIM Installation Declarations .....	10
4.2 Installing Serial Interface Module .....	11
4.3 Installing power adapter to be used with SIM .....	12
4.4 Installing MODBUS FTA .....	15
4.4.4 Guidelines for Wiring Modbus FTA to Modbus Devices .....	17
4.5 Installing ALLEN-BRADLEY FTA .....	19
4.5.5 Guidelines for wiring A-B FTA to Allen-Bradley Devices .....	22
4.6 Upgrading SIM Firmware .....	22
4.7 Converting Limited Range Modbus FTA to Extended Range Modbus FTA .....	22
4.8 About Using Limited Range Modbus FTA with R301.1 Control Builder .....	23
4.9 About Using Extended Range Modbus FTA with Pre R301.1 Control Builder .....	23
<b>Chapter 5 - SIM Configuration</b> .....	<b>24</b>
5.1 Adding SIM (TC_MUX021) Block to Project .....	24
5.2 Adding serial interface I/O channel to Control Module .....	26
5.3 Assigning SIM to Execution Environment .....	30
5.4 Loading configuration data to the SIM .....	33
<b>Chapter 6 - SIM Operation</b> .....	<b>36</b>

---

---

6.1 SIM Front Panel Display and Indicators .....	36
6.1.1 Typical startup, runtime, and firmware load SIM display indications .....	36
6.1.2 Typical channel activity LED indications .....	37
6.1.3 Typical health LED indications .....	37
6.2 Monitoring Serial Interface Functions through Station Displays .....	37
6.2.1 About Using Station Detail displays .....	37
6.2.2 About Using Station Event Summary display .....	38
6.3 Monitoring Serial Interface Functions through Monitoring Tab in Control Builder .....	38
6.3.1 Activating/inactivating SIM .....	38
6.3.2 SIM block icon appearances .....	38
6.3.3 Monitoring/Interacting with given component/block .....	39
<b>Chapter 7 - SIM Maintenance .....</b>	<b>40</b>
7.1 Periodic Checks .....	40
7.2 Recommended Spare Parts .....	40
7.3 SIM Removal and Installation Under Power .....	40
7.4 Replacing Failed SIM T C- or TK-MUX021 .....	41
7.5 Replacing Failed Power Adapter TC-/TK-SMPD01 or TC-/TK-SMPC01 .....	42
7.6 Replacing Failed Serial Interface FTA .....	42
<b>Chapter 8 - SIM Troubleshooting .....</b>	<b>43</b>
8.1 Fault Classifications .....	43
8.2 Initial Checks .....	44
8.2.1 Checking Control Builder error code reference .....	44
8.2.2 Checking front panel display and LEDs .....	44
8.2.3 Viewing error codes through serial interface block form .....	44
8.2.4 Viewing flash log .....	44
8.2.5 Viewing release information log .....	45
8.2.6 Viewing trace log .....	45
8.2.7 Checking version and revision log .....	45
8.2.8 Checking server point build log .....	45
8.2.9 Using NetworkTools to view SIM statistic data .....	45
8.2.10 Checking server point build error log .....	45
8.2.11 Checking error log .....	46
8.2.12 Using NetworkTools to capture chassis information .....	46

---

8.3 SIM Self-Test Diagnostic Codes .....	46
8.4 Fixing Common Problems .....	51
8.4.1 Loss of power .....	51
8.4.2 Poweron Self-Test Fault .....	52
8.4.3 Fatal ECC error .....	52
8.4.4 Background Diagnostic failure .....	53
8.5 Getting Further Assistance .....	53
8.5.1 Other troubleshooting sources .....	53
8.5.2 Guidelines for requesting support .....	54
<b>Chapter 9 - Allen-Bradley Interface Reference .....</b>	<b>55</b>
9.1 Array Channel Block Configuration for Allen-Bradley Interface	55
9.1.1 AUXDATA parameter configuration for Allen-Bradley interface .....	55
9.1.2 AUXDATA[6] parameter setting details .....	57
9.1.3 DEVADDR parameter configuration .....	59
9.1.4 STARTINDEX and number of elements parameters configuration .....	59
9.1.5 Report by Exception requirements .....	60
9.1.6 Performance considerations when Array Channel Block is configured for Allen-Bradley Interface .....	60
9.1.7 Array Channel block execution state when Array Channel Block is configured for Allen-Bradley Interface .....	61
9.1.8 Write processing considerations when Array Channel Block is configured for Allen-Bradley Interface .....	62
9.1.9 Diagnostic procedures and data configuration .....	63
9.1.10 Time-Out gate configuration .....	64
9.1.11 Status and error checking when Array Channel Block is configured for Allen-Bradley Interface .....	64
9.1.12 Error messages when Array Channel Block is configured for Allen-Bradley Interface .....	65
9.1.13 Special FTA to KE/KF cabling considerations .....	66
9.1.14 FTA direct to PLC-5 RS-232 Port cable considerations .....	66
9.1.15 Reference Specifications when Array Channel Block is configured for Allen-Bradley Interface .....	67
<b>Chapter 10 - MODBUS Interface Reference .....</b>	<b>69</b>
10.1 Array Channel Block Configuration for Generic MODBUS Interface .....	69
10.1.1 AUXDATA parameter configuration .....	69
10.2 Extended range versus limited range Modbus FTA .....	71
10.3 Starting element index value differences .....	71
10.3.1 Modbus loopback diagnostic .....	74

---

10.3.2 Performance considerations when Array Channel Block is configured for Generic MODBUS Interface .....	74
10.3.3 Array Channel block execution state when Array Channel Block is configured for Generic MODBUS Interface .....	75
10.3.4 Write processing considerations when Array Channel Block is configured for Generic MODBUS Interface .....	76
10.3.5 Status and error checking when Array Channel Block is configured for Generic MODBUS Interface .....	76
10.3.6 Error messages when Array Channel Block is configured for Generic MODBUS Interface .....	77
10.3.7 Special Modbus slave FTA implementation .....	78
10.3.8 Reference Specifications when Array Channel Block is configured for Generic MODBUS Interface .....	79

## CHAPTER

## 1

**ABOUT THIS DOCUMENT**

Provides information about interfacing devices with your Experion system through the Serial Interface Module in a C200 Controller chassis.

**1.1 Revision history**

Revision	Date	Description
A	August 2020	Initial release of the document.

## CHAPTER

## 2

## SERIAL INTERFACE MODULE PURPOSE

- [About the SIM](#)
- [Function block support for serial interface](#)
- [SIM processing characteristics](#)

### 2.1 About the SIM

The Serial Interface Module (SIM) is a double-width I/O module that mounts in a standard Experion chassis (or rack). It functionally serves as a communications 'bridge' between an Experion C200 or C300 Controller, and a field device connected to the SIM through a Field Termination Assembly (FTA).

The SIM supports two serial ports for bi-directional communication with two FTAs through a single FTA power adapter. It does not store or maintain any field device I/O configuration or real-time data. It only transfers these data elements between the Experion Controller and the connected field devices.

The FTA features a plug-in module that adapts I/O requirements to the specific serial interface for a given field device. The following three models are available as standard products.

- The limited range Modbus FTA model **MU-TSIM12** provides a point-to-point Modbus RTU EIA-232 (RS232) or EIA-422/485 (RS422/485) multi-drop communications interface with address support up to 9,999.
- The extended range Modbus FTA model **MU-TSIM13** provides a point-to-point Modbus RTU EIA-232 (RS232) or EIA-422/485 (RS422/485) multi-drop communications interface with address support up to 99,999.
- The Allen-Bradley (A-B) FTA model **MU-TSIA12** provides a single EIA-232 (RS-232) communications interface to A-B PLC-2, PLC-3, or PLC-5 devices using the DF1 protocol.

Chapter 2 - Serial Interface Module Purpose

Figure 2.1 Typical SIM topology with C200 Controller

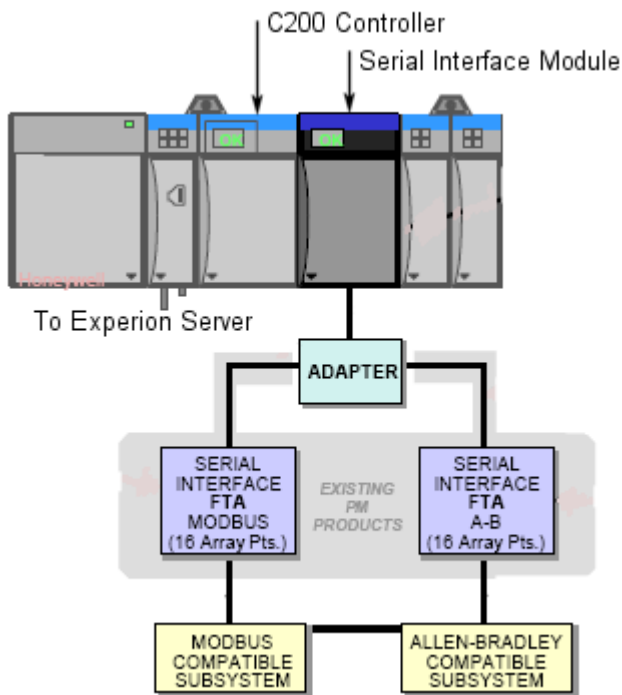
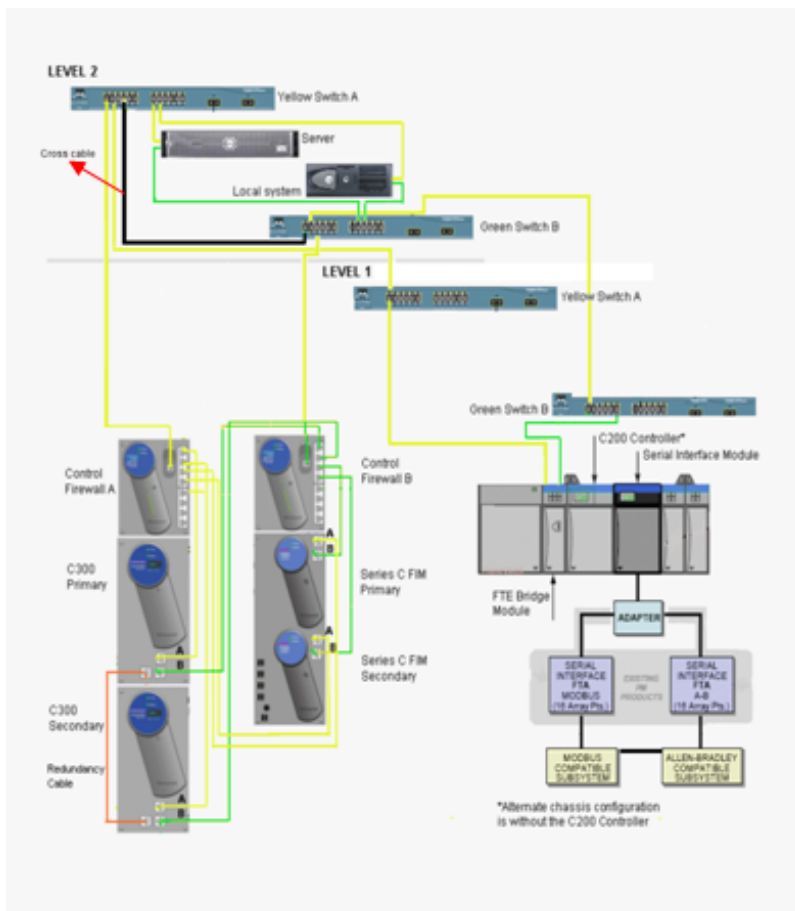

Figure 2.2 Typical SIM topology with C300 Controller



## 2.2 Function block support for serial interface

The IOMODULE library in Control Builder includes a SIM IOM function block that is labeled TC-MUX021 or TK-MUX021. The SIM block supports the configuration and assignment of a SIM to a C200 or C300 Controller. After a SIM block is assigned to a Control Execution Environment and loaded to a Controller, communications between the SIM and the controller are established, but not necessarily between the SIM and the field devices. To establish communications with field devices, you must configure, assign and load Serial Interface (SI) Array Channel function blocks through a Control Module in Control Builder.

The IOCHANNEL library in Control Builder includes the following SI Array Channel function blocks.

- Numeric (SINUMARRCH)
- Flag (SIFLAGARRCH)
- Text (SITEXTARRCH)

These blocks provide the application link between the control strategy and the data associated with a serial device. You establish the signal path and specify device specific parameters through the configuration forms for the SI Array Channel blocks in Control Builder.

The following figure provides a block diagram overview of the communications path between a serial interface field device and an SI Array Channel block.



## Chapter 2 - Serial Interface Module Purpose

The SIM block collects the writes for each Channel and sends them to the SIM every 250 milliseconds. It is possible that a write to a Channel block is rejected because the SIM block's write list is full. The following table summarizes the maximum number of writes a SIM block supports per Channel per 250 milliseconds period.

SI Array Channel Block Data Type	Maximum number of writes supported per Channel per 250 ms period
Numerics	8
Flags	16
8-Character Strings	8
16-Character Strings	4
32-Character Strings	2
64-Character Strings	1

Writes to the Channel blocks can also be rejected because the SIM is not keeping up with the writes being sent by the SIM. The SIM uses a write sequence number on a per channel basis for each write command to the SIM. Upon receipt of the write command, the SIM echoes back the last write sequence number processed. When the sequence numbers get too far apart, the Channel block rejects further writes.

Note that writes can degrade read performance to as little as one array update per second. Actual performance depends on Baud Rate and Device Protocol as well as responsiveness of the field device. You can check read/write performance and overrun statistics by viewing SIM details through the Network Tools (NTOOLS) application provided with Experion Engineering Tools. See the [Using NetworkTools to capture chassis information](#) section for more information.

The SIM block non-alarming parameters FTAAOVRNFL and FTABOVRNFL indicate write overruns. You can monitor these parameters through the SIM Detail display in Station. To alarm on the overrun condition, connect the overrun parameter to a FLAG block, which can generate an OffNormal alarm.

## CHAPTER

## 3

## SIM PLANNING AND DESIGN

- [General Planning References](#)
- [General MODBUS Protocol References](#)
- [Identifying Serial Interface Module Components](#)
- [SIM implementation considerations and restrictions](#)

### 3.1 General Planning References

Refer to the following documents for planning and design details for the Experion system in general and the Fault Tolerant Ethernet supervisory network. For the sake of brevity, this Guide does not repeat the applicable general guidelines, considerations, cautions, and so on that are covered in these other Guides.

- Control Hardware Planning Guide
- Server and Client Planning Guide
- Fault Tolerant Ethernet Overview and Implementation Guide

### 3.2 General MODBUS Protocol References

Please refer to the Modbus web site for references to general information about the MODBUS protocol.

### 3.3 Identifying Serial Interface Module Components

The following table identifies the SIM components needed to provide a serial device interface to a C200 or C300 Controller in an Experion system. The model numbers beginning with the prefix 'TK' or 'MC' are for the coated version of the component.

Component	Description	Honeywell Model Number	
<b>Serial Interface Module (SIM)</b>	Double-wide module mounts in Controller or Remote I/O chassis. Serves as a 'bridge' between the qualified third-party serial device and Experion Controller using the MODBUS protocol.	TC-MUX021	
		TK-MUX021	
<b>SIM FTA Power Adapter</b>	Accepts 24 Vdc or 85 to 265 Vac input to power the SIM FTA. Mounts on a DIN rail or flat surface		
		24 Vdc input model	TC-SMPD01 TK-SMPD01
		85 to 265 Vac input model	TC-SMPC01
			TK-SMPC01

## Chapter 3 - SIM Planning and Design

Component	Description	Honeywell Model Number
<b>SIM to Power Adapter Cable</b>	Connects SIM to Power Adapter mounted up to 10 m (32 ft) away.	TC-KSM003
	3 m (10 ft)	TC-KSM003
	5 m (16 ft)	TC-KSM005
	10 m (32 ft)	TC-KSM010
<b>Power Adapter to FTA Cable</b>	Connects Power Adapter to FTA mounted in a cabinet or outside.	
	<i>Internal Cabinet Cable</i>	
	33 cm (1 ft)	MU-KLAM01
	66 cm (2 ft)	MU-KLAM02
	100 cm (3 ft)	MU-KLAM03
	200 cm (6 ft)	MU-KLAM06
	<i>External Cable</i>	
	30 m (100 ft)	MU-KSX030
	152 m (500 ft)	MU-KSX152
305 m (1000 ft)	MU-KSX305	
<b>Limited Range Modbus FTA<sup>1</sup></b>	Supports standard MODBUS remote terminal unit (RTU) RS232 or RS422/485 communications with address support up to 9,999.	MU-TSIM12
<b>Extended Range Modbus FTA<sup>2</sup></b>	Supports standard MODBUS remote terminal unit (RTU) RS232 or RS422/485 communications with address support up to 65,535 (99,999).	MU-TSIM13 MC-TSIM13
<b>Allen-Bradley DF1 Modbus FTA<sup>1</sup></b>	Supports Allen-Bradley DF1 serial protocol over RS232 only with address support up to 65535.	MU-TSIA12
<p><sup>1</sup>MU-TSIM12 and MU-TSIA12 use industry standards to support many industrial devices. Contact your Honeywell representative for support of non-standard protocols. Note that protocols developed under the Honeywell TPS, PM/APM/HPM Serial Device Interface protocol or the Smart Transmitter Interface (STI) protocol are not supported.</p> <p><sup>2</sup>MU/MC-TSIM13 requires Experion R301.1 or greater version of Control Builder for extended address range support. Otherwise, this FTA is functionally equivalent to the limited range MU-TSIM12 model. Contact your Honeywell representative for support of non-standard protocols. Note that protocols developed under the Honeywell TPS, PM/APM/HPM Serial Device Interface protocol or the Smart Transmitter Interface (STI) protocol are not supported.</p>		

## 3.4 SIM implementation considerations and restrictions

The following is a list of things to consider when planning to implement a serial interface application.

- The Serial Interface Module can be installed in any available chassis slot pair excluding slot zero.
- A Controller with CEE-50ms can support up to three SIMs, or only one SIM with CEE-5ms. This corresponds to support for up to 64 IOM connections for CEE 50ms or only 12 IOM connections for CEE 5ms.
- The fastest update rate supported by the SIM is 250 milliseconds.
- A remote I/O chassis power supply will support up to three SIMs.
- A Controller chassis power supply will support up to two SIMs, since the C200 CPM consumes

roughly the same power as a SIM.

- The SIM supports up to two serial ports or two FTAs with up to 16 serial devices per FTA.
- A SIM supports a maximum of 32 SI Array Channel blocks through a SIM block with no restrictions on the mix of Array Channel block data types.
- A Serial Interface NUMERIC Array Channel block supports up to 64 numeric process variables.
- A Serial Interface FLAG Array Channel block supports up to 512 process variable flags.
- A Serial Interface TEXT Array Channel block supports up to 64 Unicode characters.
- Each SI Array Channel block is mapped to a single serial device. (Note that multiple SI Array Channel blocks can be mapped to a single serial device.)
- Every four SI Array Channel blocks associated with a given SIM block are equivalent to using one traditional analog/discrete IOM. A single rack-mounted SIM can represent from 1 to 8 traditional IOMs, in terms of the maximum IOM capacity, based on a ratio of four Array Channel blocks equal one traditional IOM.
- The 32 Array Channel blocks associated with a SIM block are allocated to the two FTAs as follows.
  - Channels 0 to 15 to FTA 'A'
  - Channels 16 to 31 to FTA 'B'
- When only one FTA is used, it must be configured as FTA 'A' and channels 0 to 3 must be used for at least one connection.
- For the most efficient use of Controller I/O connections, assign channels consecutively starting from channel 0. If high throughput is required, especially high write throughput, assign fewer arrays to each I/O connection.
- An FTA serial port operates at a data rate of up to 19.2 kilobaud.
- Communication between the SIM and the FTA operates at 38.4 kilobaud.
- The FTA to Power Adapter cable can be up to 300 meters (1000 feet) long.
- The Power Adapter to SIM cable can be up to 10 meters (32 feet) long.
- Be sure the 24Vdc power supply that is used to power the TC/TK-SMPD01 SIM FTA Power Adapter is **dedicated** to powering only that Power Adapter and is **not** used to power any other equipment. The power supply must also be a floating power source, such as a DIN rail-mounted Phoenix Contact (MCR-PS-24DC/24DC/200) power supply with floating 24Vdc output.

## CHAPTER

## 4

## SIM INSTALLATION AND UPGRADES

- [SIM Installation Declarations](#)
- [Installing Serial Interface Module](#)
- [Installing power adapter to be used with SIM](#)
- [Installing MODBUS FTA](#)
- [Installing ALLEN-BRADLEY FTA](#)
- [Upgrading SIM Firmware](#)
- [Converting Limited Range Modbus FTA to Extended Range Modbus FTA](#)
- [About Using Limited Range Modbus FTA with R301.1 Control Builder](#)
- [About Using Extended Range Modbus FTA with Pre R301.1 Control Builder](#)

## 4.1 SIM Installation Declarations

**ATTENTION**

This equipment shall be installed in accordance with the requirements of the National Electrical Code (NEC), ANSI/NFPA 70, or the Canadian Electrical Code (CEC), C22.1. It is intended to be mounted within an enclosure or suitable environment acceptable to the local *authority having jurisdiction*, as defined in the NEC, or *authorized person* as defined in the CEC.

**WARNING**

Electrostatic discharge can damage integrated circuits or semiconductors if you touch connector pins or tracks on a printed wiring board. Follow these guidelines when you handle any electronic component:

- Touch a grounded object to discharge static potential,
- Wear an approved wrist-strap grounding device,
- Do not touch the wire connector or connector pins,
- Do not touch circuit components inside a component,
- If available, use a static safe workstation,
- When not in use, keep the component in its static shield box or bag.

**WARNING**

Unless the location is known to be non-hazardous, do **not**:

## Chapter 4 - SIM Installation and Upgrades

- connect or disconnect cables,
  - install or remove fuses, terminal blocks, and so on,
- while the component is powered.

## 4.2 Installing Serial Interface Module

You must review the [SIM implementation considerations and restrictions](#) section in this document, prior to installing SIM.

### 4.2.1 Prerequisites

- You have the SIM and associated components on hand.
- You have installed the chassis and taken steps to minimize Electrostatic Discharge (ESD).
- Check that no power is applied to the chassis.

### 4.2.2 To install SIM in chassis

1. Position the module at the planned chassis slot location. For example, slots 3 and 4.  
(Remember that slot numbering is zero-based and the left most slot is number '0'.)
2. Align the module's circuit board with the top and bottom chassis guides.

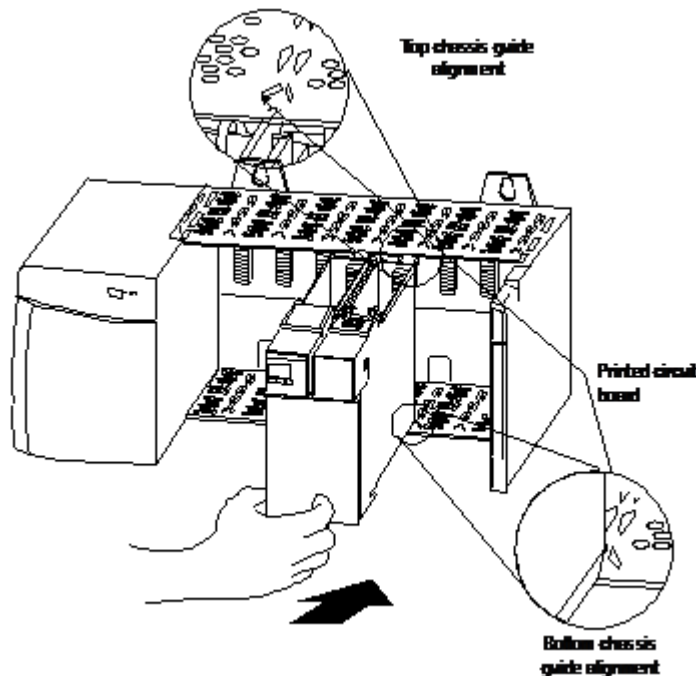

3. Slide the module into the chassis until the module tabs 'click' into position.

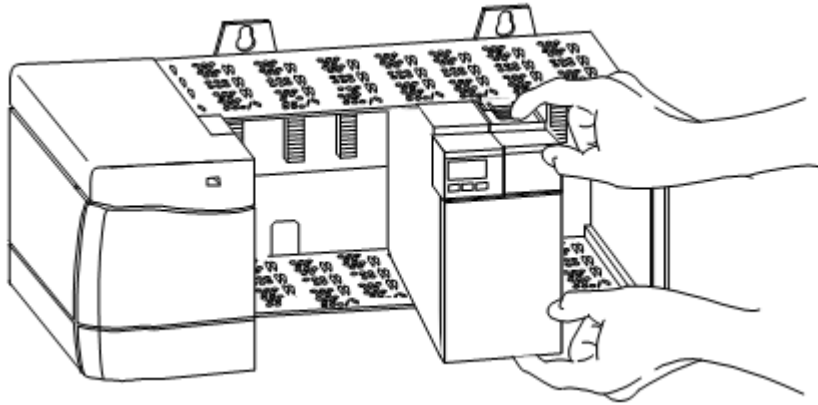

4. Connect the SIM to Power Adapter cable assembly.

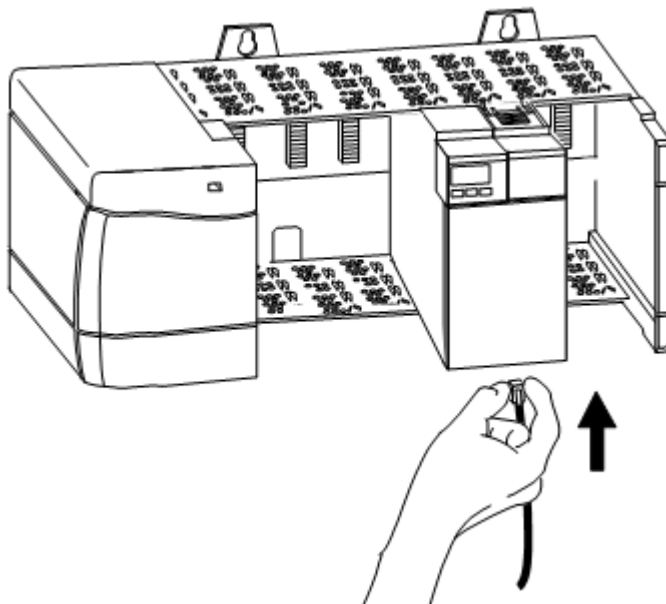

5. Go to the next section *Installing the Power Adapter*.

## 4.3 Installing power adapter to be used with SIM

### 4.3.1 Prerequisites

- You have installed the SIM in the chassis per the previous procedure.
- You have determined if your power adapter is to be DIN Rail mounted or mounted directly to a flat surface.
- You have taken steps to minimize Electrostatic Discharge (ESD).

#### CAUTION

Be sure the 24Vdc power supply that you use to power the TC/TK-SMPD01 SIM FTA Power Adapter is **dedicated** to powering only that Power Adapter and is **not** used to power any other equipment. The power supply must also be a floating power source, such as a DIN rail-mounted Phoenix Contact (MCR-PS-24DC/24DC/200) power supply with floating 24Vdc

## Chapter 4 - SIM Installation and Upgrades

---

output. Otherwise, voltage transients on the user-supplied 24Vdc to the Power Adapter may damage the associated TC/TK-MUX021 SIM in the chassis. You can also use the ac-powered TC/TK-SIMPC01 SIM FTA Power Adapter instead of the dc-powered version, as an alternative.

- You have a Philips screwdriver and a drill, if you are mounting the power adapter on a flat surface.
- If you are mounting the power adapter on a flat surface, observe the following precautions:

### CAUTION

- Do not drill holes for a Power Adapter above an already installed chassis. Debris from the drilling can damage or short the chassis backpanel, and short the backpanel card-edge connectors.
  - If the Power Adapter does not lay flat before the screws are tightened, use additional washers as shims. This will ensure that the circuit board is not warped or cracked by tightening the screws. Warping a Power Adapter could cause a malfunction and prevent proper operation.
- If you are mounting the power adapter on a DIN rail, you are responsible for supplying and installing the DIN rails.

### 4.3.2 To mount power adapter on a flat surface

1. Position the Power Adapter on the mounting surface. While holding it in place, use a pencil or center punch to mark the four mounting hole locations on the surface.
2. Remove the Power Adapter and drill tap holes at the marked locations.

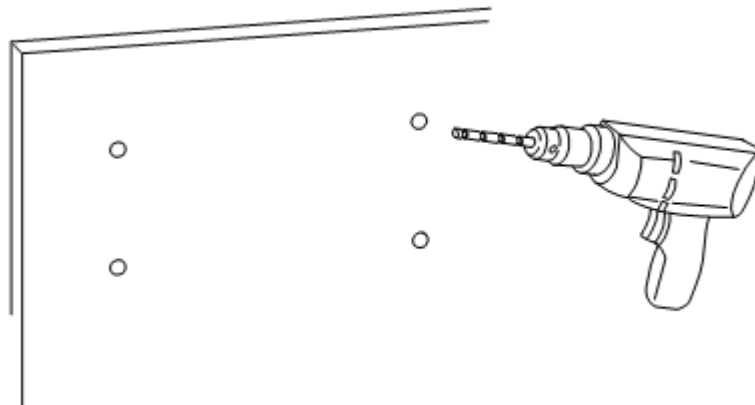

3. Using the screws provided, mount the Power Adapter to the surface.

Chapter 4 - SIM Installation and Upgrades

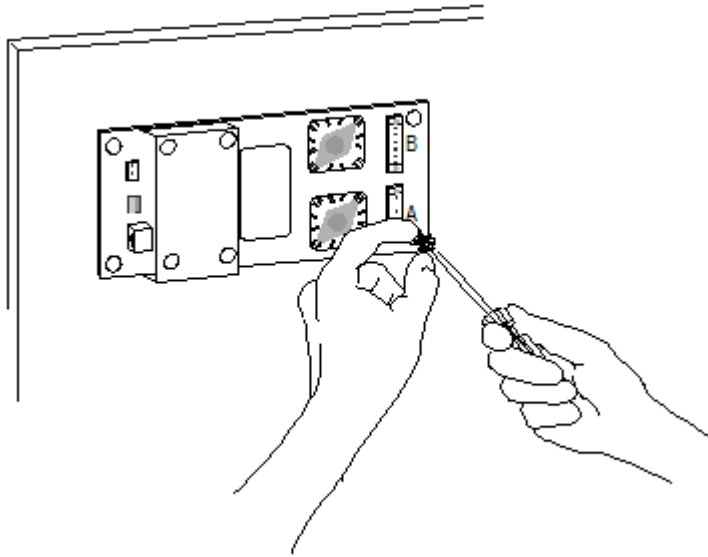

4. Connect the SIM-to-Power Adapter cable to terminal connector J1 on the Power Adapter.

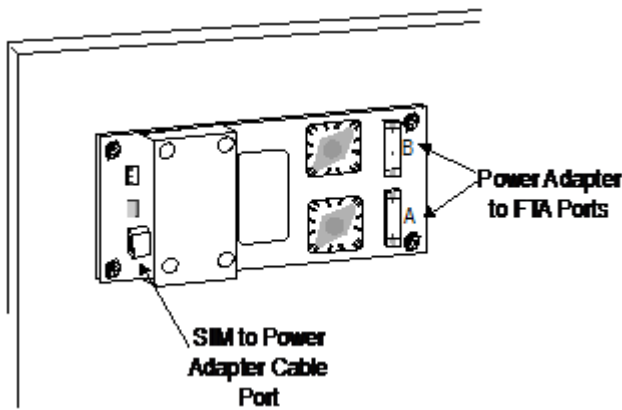

For Vdc model, connect leads from 24 Vdc power supply to J5 terminals on the adapter, observing polarity.

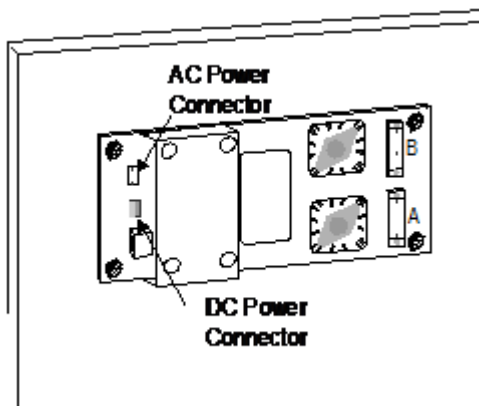

For Vac model, connect leads from 120/240 Vac line to J4 terminals L1, L2, and GND.

5. Go to the next section Installing Modbus FTA or Installing Allen-Bradley FTA, as applicable.

## 4.4 Installing MODBUS FTA

You can mount the Modbus FTA on a standard FTA Mounting Channel, DIN rail (35 x 7.5 mm top hat rail), or flat surface.

Do **not** expose the FTA to the weather. It is designed for mounting in a cabinet or a controlled environment.

Be sure the FTA is grounded either directly or through the mounting means.

### Overall Modbus interface connections

The following figure shows the typical component connections associated with a Modbus FTA installation for reference.

Figure 4.1 Typical Modbus Serial Interface connections

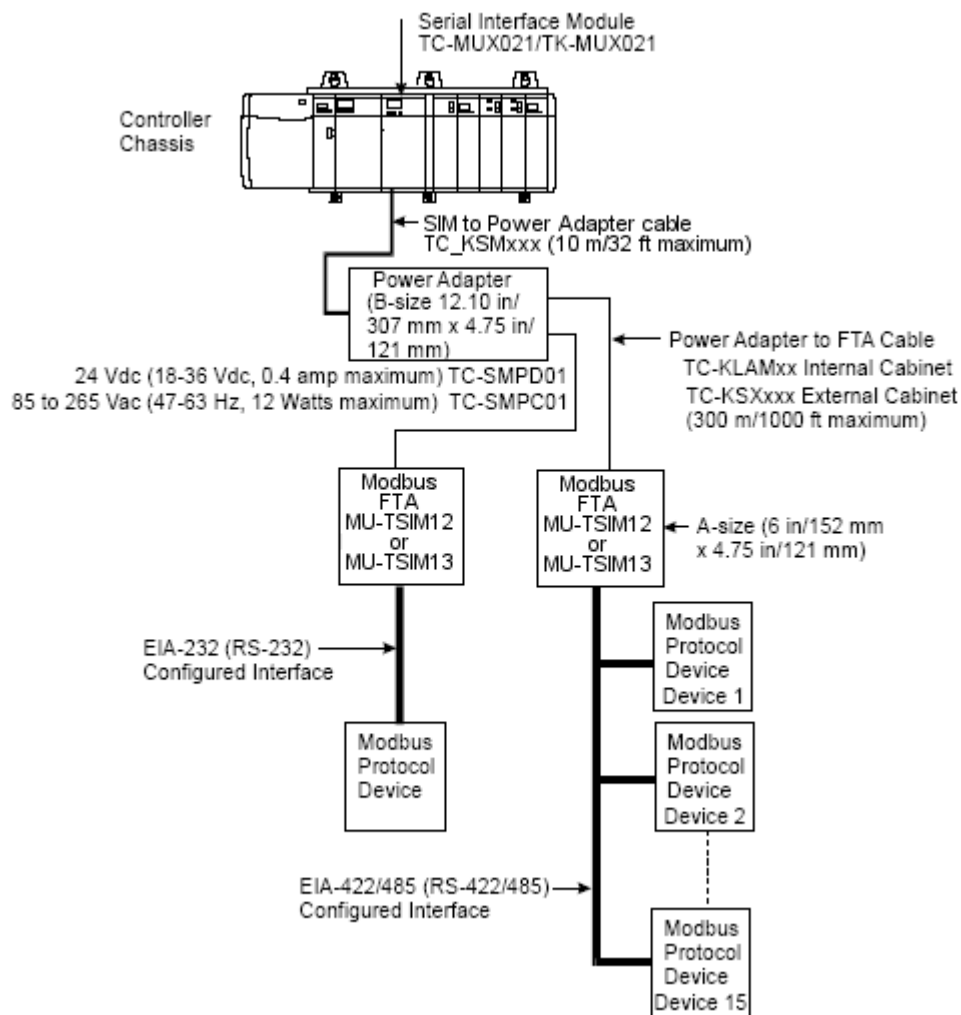

### 4.4.1 Prerequisites

You have the applicable Modbus FTA and associated cables on hand.

- Limited-Range Modbus FTA model MU-TSIM12, or
- Extended-Range Modbus FTA model MU/MC-TSIM13

## 4.4.2 Mounting Modbus FTA

1. Locate the mounting holes in each corner.
2. To mount on a DIN rail, you must attach the DIN rail adapter to the bottom of the FTA using the hardware supplied.
3. To mount on an FTA channel, attach to the Mounting Channel standoffs.
4. To mount on a flat surface, mark the location of the four mounting holes, drill holes and use screws and non-metallic spacers to attach the FTA to the flat surface/wall.

## 4.4.3 To wire Modbus FTA to Power Adapter

1. Is the Modbus FTA mounted in a cabinet with the Power Adapter?  
If the answer is **Yes**, be sure you have the appropriate number and length of Honeywell internal cable MU-KLAMxx on hand. Go to the next Step.  
If the answer is **No**, be sure you have the appropriate number and length of Honeywell external cable MU-KSXxxx on hand. Go to the next Step.  
(Note that the cable must have two individually shielded, twisted pairs.)
2. On one twisted pair mark one lead P- and the other P+ at both ends of the cable. On the other twisted pair mark one lead S- and the other S+ at both ends of the cable. Repeat this for other cables, as applicable.
3. Locate the J2 (CHANNEL A), 6-pin connector on the Power Adapter. Observing polarity, connect the cable lead marked P- to pin 1 - PWR CUR and lead marked P+ to pin 2 + PWR CUR. Connect the shield wire for this pair to pin 3 SHD. Observing polarity, connect the cable lead marked S- to pin 4 - SER and lead marked S+ to pin 5 + SER. Connect the shield wire for this pair to pin 6 SHD. See the connection diagram in the following Figure for reference.  
(Note that the shield wires are connected to ground at the Power Adapter end only.)
4. Locate the J1, 4-pin connector on the FTA 'A'. Observing polarity, connect the cable lead marked P- to pin 1 - PWR CUR and lead marked P+ to pin 2 + PWR CUR. Trim the shield wire for this pair close to the cable insulation. Observing polarity, connect the cable lead marked S- to pin 3 - SER and lead marked S+ to pin 4 + SER. Trim the shield wire for this pair close to the cable insulation. See the connection diagram in the following Figure for reference.
5. Do you have a second FTA to be connected to the Power Adapter?  
If the answer is **Yes**, continue with Step 6.  
If the answer is **No**, exit this procedure and go to the next section *Wiring Modbus FTA to Modbus devices*.
6. Locate the J3 (CHANNEL B), 6-pin connector on the Power Adapter. Observing polarity, connect the cable lead marked P- to pin 1 - PWR CUR and lead marked P+ to pin 2 + PWR CUR. Connect the shield wire for this pair to pin 3 SHD. Observing polarity, connect the cable lead marked S- to pin 4 - SER and lead marked S+ to pin 5 + SER. Connect the shield wire for this pair to pin 6 SHD. See the connection diagram in the following Figure for reference.  
(Note that the shield wires are connected to ground at the Power Adapter end only.)
7. Locate the J1, 4-pin connector on the FTA 'B'. Observing polarity, connect the cable lead marked P- to pin 1 - PWR CUR and lead marked P+ to pin 2 + PWR CUR. Trim the shield wire for this pair close to the cable insulation. Observing polarity, connect the cable lead marked S- to pin 3 - SER and lead marked S+ to pin 4 + SER. Trim the shield wire for this pair close to the cable insulation. See the connection diagram in the following Figure for reference.

Chapter 4 - SIM Installation and Upgrades

- Go to the next section *Wiring Modbus FTA to Modbus devices*.

Figure 4.2 Power Adapter to Serial Interface FTA Wiring

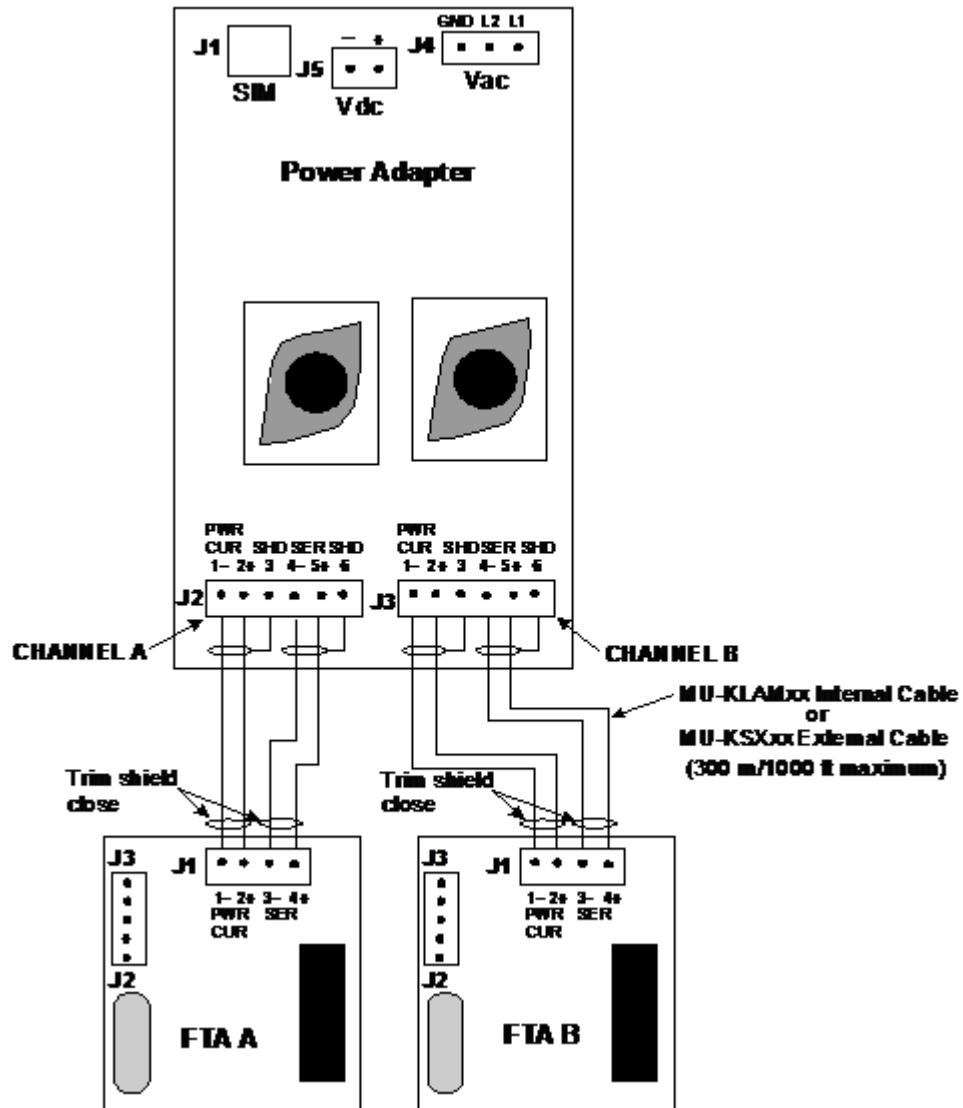

- [Guidelines for Wiring Modbus FTA to Modbus Devices](#)

#### 4.4.4 Guidelines for Wiring Modbus FTA to Modbus Devices

##### To make EIA-232 (RS-232) connections

You will need a null modem cable with a 25-pin, male connector to connect the EIA-232 Modbus device to the J2, DB-25 type connector on the FTA. Use the J2 connector pinout data in the following Figure to construct the EIA-232 interface cable. Since individual Modbus device connections may vary, be sure to modify the common EIA-232 pinouts shown in the following Figure, so that the FTA Transmit Data pin (2) connects to the Modbus device Receive Data pin and the FTA Receive Data pin (3) connects to the Modbus device Transmit Data pin. Be sure the length of the EIA-232 interface cable does not exceed 15 meters (50 feet).

Figure 4.3 Pins common to RS-232 25-pin connector and FTA J2, DB-25 type connector.

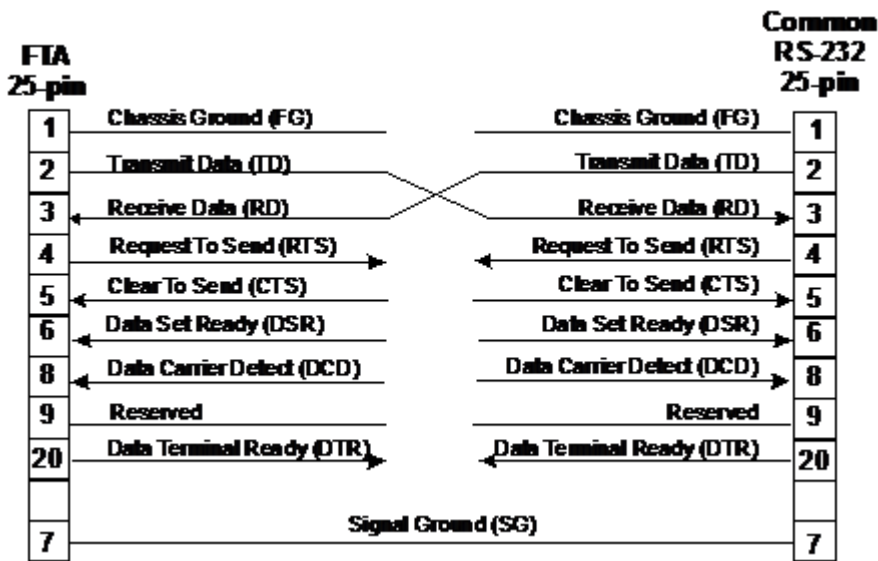

### To Make EIA-422/485 connections

You will need appropriate cable, such as Belden Corporation type 9271 twin axial, to connect up to 15 EIA-422/485 Modbus devices in multidrop fashion to the J3, 5-pin connector on the FTA. Use the connection details shown in the following Figure and the following guidelines to configure a multidrop EIA-422/485 interface.

The recommended maximum length for the interface cable is 300 meters (1000 feet). However, this can be extended up to 1220 meters (4000 feet) with the appropriate cable (Belden type 9182). Please consult with your Honeywell representative for the recommended cable.

To avoid potential ground loops, connect the shield for the interface cable to ground at the FTA end only. See the following Figure for details.

To minimize signal reflections, connect a 120 ohm, +/- 10%, 1/2 Watt resistor across J3 pins 1 and 5 and across the Data + and Data - terminals on the last device in the link. (Note that the resistor value may be different based on the requirements of the actual cable used.)

The FTA includes two 1/4 Ampere fuses (F1 and F2) to protect it from excessive current on the data lines.

Chapter 4 - SIM Installation and Upgrades

Figure 4.4 Modbus FTA EIA-422/485 connections.

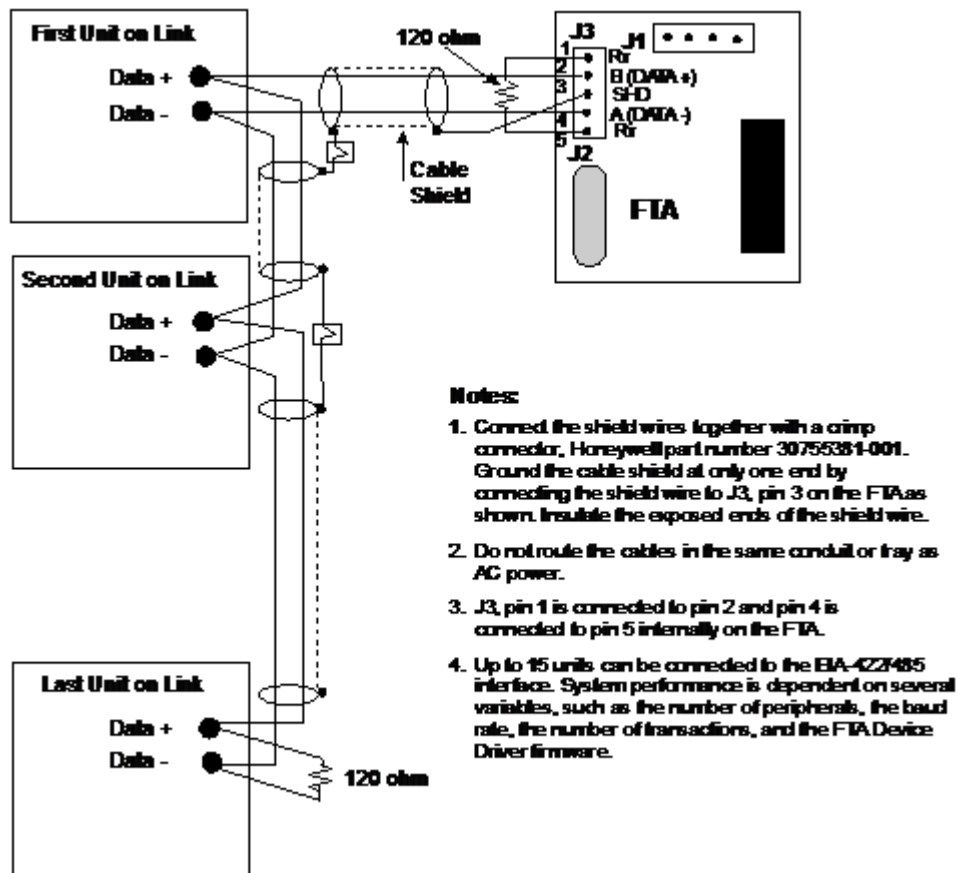

## 4.5 Installing ALLEN-BRADLEY FTA

### ATTENTION

Connections and options are subject to change by Allen-Bradley without notice to or from Honeywell. Please Contact Allen-Bradley for the latest interface.

You can mount the Allen-Bradley FTA on a standard FTA Mounting Channel, DIN rail (35 x 7.5 mm top hat rail), or flat surface.

Do **not** expose the FTA to the weather. It is designed for mounting in a cabinet or a controlled environment.

Ensure that the FTA is grounded either directly or through the mounting means.

### 4.5.1 Overall Allen-Bradley interface connections

- The following figures show the typical component connections associated with an Allen-Bradley FTA installation for reference.

Figure 4.5 Typical connection of Allen-Bradley devices to the SIM.

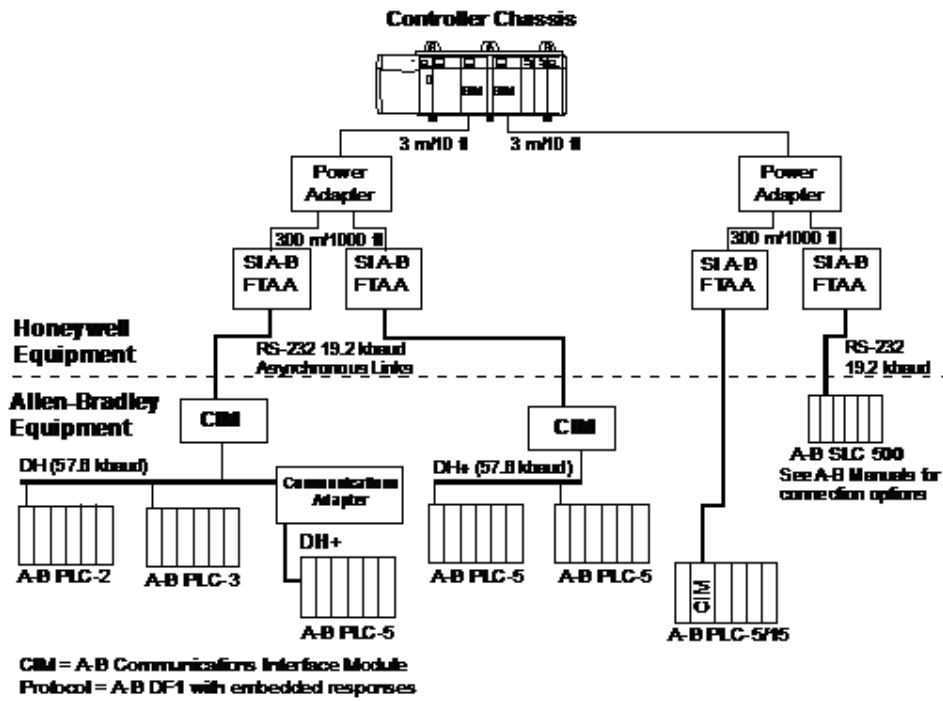
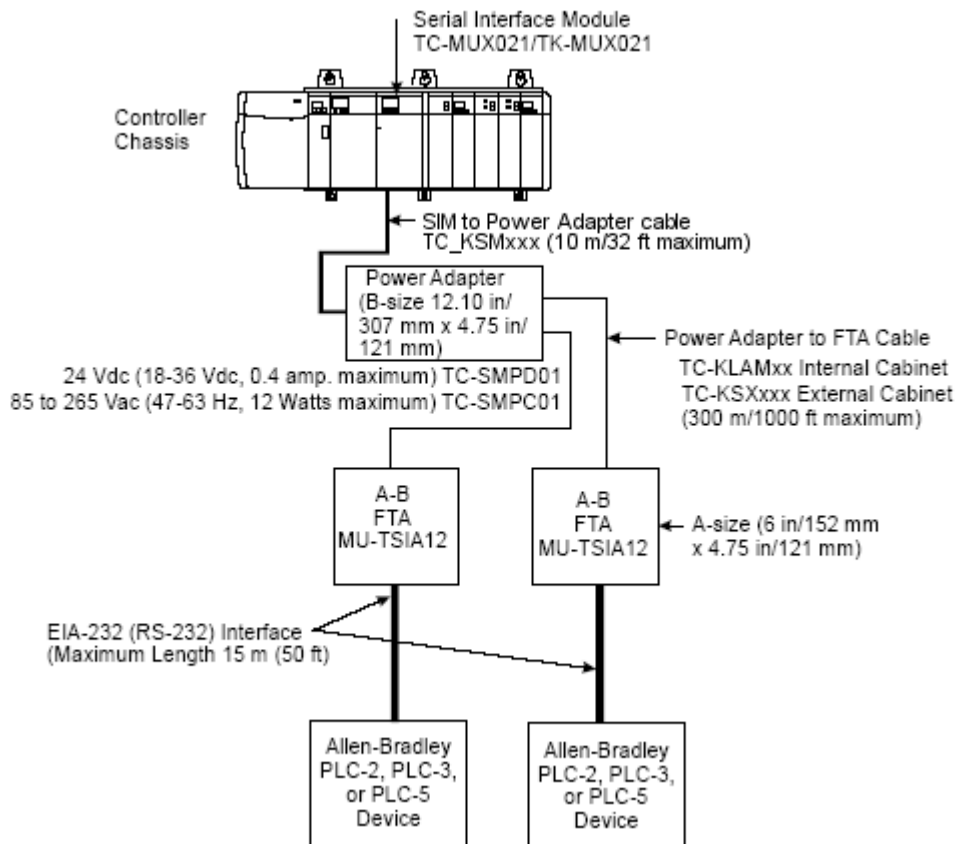

Figure 4.6 Typical Allen-Bradley Serial Interface connections.



## 4.5.2 Prerequisites

- You have the Allen-Bradley FTA and associated cables on hand.

## 4.5.3 Mounting Allen-Bradley FTA

1. Locate the mounting holes in each corner.
2. To mount on a DIN rail, you must attach the DIN rail adapter to the bottom of the FTA using the hardware supplied.
3. To mount on an FTA channel, attach to the Mounting Channel standoffs.
4. To mount on a flat surface, mark the location of the four mounting holes, drill holes and use screws and non-metallic spacers to attach the FTA to the flat surface/wall.

## 4.5.4 To wire Allen-Bradley FTA to Power Adapter

1. Is the A-B FTA mounted in a cabinet with the Power Adapter?  
If the answer is **Yes**, be sure you have the appropriate number and length of Honeywell internal cable MU-KLAMxx on hand. Go to the next Step.  
If the answer is **No**, be sure you have the appropriate number and length of Honeywell external cable MU-KSXxxx on hand. Go to the next Step.  
(Note that the cable must have two individually shielded, twisted pairs.)
2. On one twisted pair mark one lead P- and the other P+ at both ends of the cable. On the other twisted pair mark one lead S- and the other S+ at both ends of the cable. Repeat this for other cables, as applicable.
3. Locate the J2 (CHANNEL A), 6-pin connector on the Power Adapter. Observing polarity, connect the cable lead marked P- to pin 1 - PWR CUR and lead marked P+ to pin 2 + PWR CUR. Connect the shield wire for this pair to pin 3 SHD. Observing polarity, connect the cable lead marked S- to pin 4 - SER and lead marked S+ to pin 5 + SER. Connect the shield wire for this pair to pin 6 SHD. See the connection diagram in the previous [Figure 2](#) Figure for reference.  
(Note that the shield wires are connected to ground at the Power Adapter end only.)
4. Locate the J1, 4-pin connector on the FTA 'A'. Observing polarity, connect the cable lead marked P- to pin 1 - PWR CUR and lead marked P+ to pin 2 + PWR CUR. Trim the shield wire for this pair close to the cable insulation. Observing polarity, connect the cable lead marked S- to pin 3 - SER and lead marked S+ to pin 4 + SER. Trim the shield wire for this pair close to the cable insulation. See the connection diagram in the previous [Figure 2](#) Figure for reference.  
If the answer is **Yes**, continue with Step 6.  
If the answer is **No**, exit this procedure and go to the next section *Wiring A-B FTA to Allen-Bradley devices*.
5. Do you have a second A-B FTA to be connected to the Power Adapter?
6. Locate the J3 (CHANNEL B), 6-pin connector on the Power Adapter. Observing polarity, connect the cable lead marked P- to pin 1 - PWR CUR and lead marked P+ to pin 2 + PWR CUR. Connect the shield wire for this pair to pin 3 SHD. Observing polarity, connect the cable lead marked S- to pin 4 - SER and lead marked S+ to pin 5 + SER. Connect the shield wire for this pair to pin 6 SHD. See the connection diagram in the previous [Figure 2](#) Figure for reference.  
(Note that the shield wires are connected to ground at the Power Adapter end only.)
7. Locate the J1, 4-pin connector on the FTA 'B'. Observing polarity, connect the cable lead marked P- to pin 1 - PWR CUR and lead marked P+ to pin 2 + PWR CUR. Trim the shield wire for this pair close to the cable insulation. Observing polarity, connect the cable lead marked S- to pin 3 - SER and lead marked S+ to pin 4 + SER. Trim the shield wire for this pair close to the

cable insulation. See the connection diagram in the previous [Figure 2](#) Figure for reference.

8. Go to the next section *Wiring A-B FTA to Allen-Bradley devices*.

- [Guidelines for wiring A-B FTA to Allen-Bradley Devices](#)

## 4.5.5 Guidelines for wiring A-B FTA to Allen-Bradley Devices

You will need a null modem cable with a 25-pin, male connector to connect the EIA-232 Allen-Bradley device to the J2, DB-25 type connector (female) on the FTA. Use the J2 connector pinout data in the previous [Figure 1](#) Figure to construct the EIA-232 interface cable. Since individual A-B device connections may vary, be sure to modify the common EIA-232 pinouts shown in the Figure, so that the FTA Transmit Data pin (2) connects to the A-B device Receive Data pin and the FTA Receive Data pin (3) connects to the A-B device Transmit Data pin. Refer to the pinout description in the Allen-Bradley device manual and the [Special FTA to KE/KF cabling considerations](#) in the *Allen-Bradley Interface Reference* section. Observe the following general cabling guidelines.

- The FTA, J2 connector, Transmit pin 2 must connect to the A-B device Receive pin.
- The FTA, J2 connector, Receive pin 3 must connect to the A-B device Transmit pin.
- Never connect the Chassis and Signal grounds together.
- The A-B device may require other pins to be jumpered, refer to the A-B device manual and the [FTA direct to PLC-5 RS-232 Port cable considerations](#) in the *Allen-Bradley Interface Reference* section..
- When connecting to an A-B PLC, usually through a KE or KA module, be sure the device has the latest firmware available from Allen-Bradley.
- Be sure the length of the EIA-232 interface cable does not exceed 15 meters (50 feet).

## 4.6 Upgrading SIM Firmware

Please refer to the Upgrading boot and personality images in chassis-based components section in the *Control Hardware and I/O Module Firmware Upgrade Guide* for information about upgrading firmware in a Serial Interface Module.

## 4.7 Converting Limited Range Modbus FTA to Extended Range Modbus FTA

The following procedure outlines how to convert an existing limited range Modbus FTA to an extended range one given that specified prerequisites are met.

### 4.7.1 Prerequisites

- You are running Control Builder version R301.1 or greater.
- The existing Programmable Logic Controller is capable of larger addresses and had been used to access lower address (<9,999) registers through a limited range FTA.
- You have logged on with sufficient security level to make changes in a control strategy in Control Builder.
- You need to provide SIM flag point access to the read/write bit flag value at an extended address (for example 33, 000) in an existing Programmable Logic Controller.

#### ATTENTION

If you are running pre R301.1 Experion software, the Control Execution Environment (CEE) will not accept loads of array blocks with STARTINDEX values above 99,999.

**CAUTION**

We recommend that you proceed with **extreme caution** whenever replacing any component in a control system. Be sure the system is offline or in a safe operating mode.

Component replacements may also require corresponding changes in the control strategy configuration through Control Builder, as well as downloading appropriate data to the replaced component.

## 4.7.2 To convert limited range Modbus FTA to extended one

1. Replace limited range Modbus FTA model MU-TSIM12 with extended range Modbus FTA model **MU-TSIM13** or **MC-TSIM13**. See the previous [Installing MODBUS FTA](#) section for more information.
2. In **Project** tree in Control Builder, reconfigure all existing serial interface I/O channel blocks assigned to the SIM channels associated with the replaced limited range Modbus FTA to change the most significant digit of the Starting Element Address (STARTINDEX) so it agrees with the extended address format. And, reconfigure the AUXDATA [5] parameter entry to 65535.0 to enable the extended addressing mode on the extended range Modbus FTA.
3. Re-load modified control strategies in **Project** to the Controller.
4. This completes the procedure. Resume normal operation.

## 4.8 About Using Limited Range Modbus FTA with R301.1 Control Builder

You can use a limited-range Modbus FTA with a R301.1 or greater Control Builder as long as you only need to access addresses in the range of 1 to 9,999. If you need to access addresses above 9,999, you need to convert to an extended range Modbus FTA as outlined in the previous section.

## 4.9 About Using Extended Range Modbus FTA with Pre R301.1 Control Builder

You can use an extended range Modbus FTA with a pre R301.1 Control Builder as long as you only need to access addresses in the range of 1 to 9,999. In this case, you must configure the AUXDATA [5] parameter value as NaN to **disable** the extended addressing mode on the extended range Modbus FTA. If you need to access addresses above 9,999, you will need to upgrade your Experion system to R301.1 to get the expanded features of the R301.1 Control Builder. In this case, you must configure the AUXDATA[5] parameter value as 65535.0 to **enable** the extended addressing mode on the extended range Modbus FTA.

## CHAPTER

## 5

## SIM CONFIGURATION

- [Adding SIM \(TC\\_MUX021\) Block to Project](#)
- [Adding serial interface I/O channel to Control Module](#)
- [Assigning SIM to Execution Environment](#)
- [Loading configuration data to the SIM](#)

## 5.1 Adding SIM (TC\_MUX021) Block to Project

You can only view SIM (TC\_MUX021) blocks in the **Project** tab set for **Assignment** view. The **Assignment** view shows the relationship among all blocks while the **Containment** view only shows templates that contain other templates or Control Modules (CM), Sequential Control Modules (SCM), and basic blocks. To toggle the view, right-click in an open area of the tab window and select **Assignment View** or **Containment View** from the list, as applicable.

Each TC\_MUX021 block is automatically assigned a unique default tag name when it is created. If your system will include multiple SIM blocks, you may want to adopt a more structured syntax for naming them.

The block tag or module name can be up to 40 characters long and must contain at least one letter (A-Z). It must not contain an embedded space or leading space, and dots are allowed in parameter naming only.

The item name can be up to 40 characters long and must contain at least one letter (A-Z). It is a name by which an entity is known within the context of the enterprise model. The Item name must be unique among children of the same containment parent in the Enterprise Model Builder hierarchy and should conform to the standard convention names within the system.

The module description text can be up to 132 characters long and appears on both detail and group displays.

### 5.1.1 Prerequisites

- You have started Configuration Studio and launched the Control Builder application.
- You have logged on with sufficient privileges to create control strategies using Control Builder.
- If applicable, you have configured the applicable IP addresses when you set up your FTE network.

## 5.1.2 To add SIM block to Project

1. On the **File** menu, click **New > I/O Modules > IOMODULE > TC-MUX021 - Serial Interface, 32 ch**. Calls up the TC\_MUX021 Block parameters configuration form **Main** tab with cursor in the **Item Name** field, as shown in the following sample illustration.

IOMODULE:TC-MUX021 Block, TC\_MUX021\_252 - Parameters [Project]

Main | Module Configuration | Channel Configuration | QVCS | Server History | Server Displays | Control Confirmation | Identification

Module Name:

Item Name:

Module Description:

I/O Module Information:

Module Type:

Channel Number	Channel Name
0	
1	
2	
3	
4	
5	
6	
7	
8	
9	
10	
11	
12	
13	
14	
15	

IO Rack Addresses:

IOM Slot Number:

Remote IO Chassis MAC Address:

ControlNet Module Slot Number (connected to IO Chassis):

Show Parameter Names

OK Cancel Help

2. If you want to change the default module name, double-click the **Module Name** box to highlight it and key in the desired module name. Click the cursor in the **Item Name** box. Otherwise, go to Step 3.
3. With cursor in the **Item Name** box, Key in the name of the item this object will be associated with in the Enterprise Model Builder hierarchy.
4. Click the **Module Description** box and key in the desired descriptive text to be used on displays.
5. Double-click the **IOM Slot Number** box and key in the number of the first slot the SIM occupies in the chassis.
6. If the SIM is installed in a remote Series A I/O chassis, double-click the **Remote IO Chassis MAC Address** box and key in the MAC address of the uplink ControlNet Interface (CNI) module installed in the remote chassis.
7. If the SIM is installed in a C200 Controller chassis, you can skip this step.
8. If the SIM is installed in a remote Series A I/O chassis, double click the **ControlNet Module Slot Number (connected to IO Chassis)** box and key in the number of the slot the downlink CNI module occupies in the C200 Controller chassis.
9. If the SIM is installed in a C200 Controller chassis, you can skip this step.
10. Click the **Module Configuration** tab to display it.
11. Be sure the check box for the **Alarming Enabled** function is checked, if you want alarm reporting enabled. A blank check box means that the alarm reporting function is disabled.
12. Click the **Server History** tab to display it.

13. Use this tab to configure desired history parameters and create or edit server scripts. See the *Control Building Guide* and/or the online help for more information.
14. Click the **Server Displays** tab to display it.
15. Use this tab to configure parameters associated with Station displays. See the *Control Building Guide* and/or the online help for more information.
16. Click the **Control Confirmation** tab to display it.
17. Use this tab to configure parameters for control confirmation associated with the licensed Electronic Signature option. See the *Control Building Guide* and/or the online help for more information.
18. Click the **Identification** tab to display it
19. Use this tab to configure parameters associated with the licensed template option. See the *Control Building Guide* and/or the online help for more information.
20. When you completed entering configuration data, click the **OK** button to close the configuration form and add the icon for the SIM to the **Project** tab.
21. This completes the procedure. Go to the next section.

## 5.2 Adding serial interface I/O channel to Control Module

The following procedure adds a Serial Interface Numeric Array channel block to a CM and assigns a channel to a SIM for example purposes only. You can easily adapt this procedure to apply to another Serial Interface Array channel block.

Each IOCHANNEL block is automatically assigned a unique default tag name when it is created. If your system will include multiple IOCHANNEL blocks, you may want to adopt a more structured syntax for naming them.

The channel name can be up to 16 characters long and must contain at least one letter (A-Z). It must not contain an embedded space or leading space, and dots are allowed in parameter naming only.

All illustrations used in the following procedure are for example purposes only.

### 5.2.1 Prerequisites

- You have started Configuration Studio and launched the Control Builder application.
- You have logged on with sufficient privileges to create control strategies using Control Builder.
- You have added a SIM block to the **Project** tab.
- You have created a Control Module in the **Project** tab.

## Chapter 5 - SIM Configuration

## 5.2.2 To add serial interface channel block to CM

1. In the **Project** tab, double-click the icon for the Control Module that is to include a serial interface I/O channel block to open it in the Control Drawing pane, as shown in the following sample illustration.

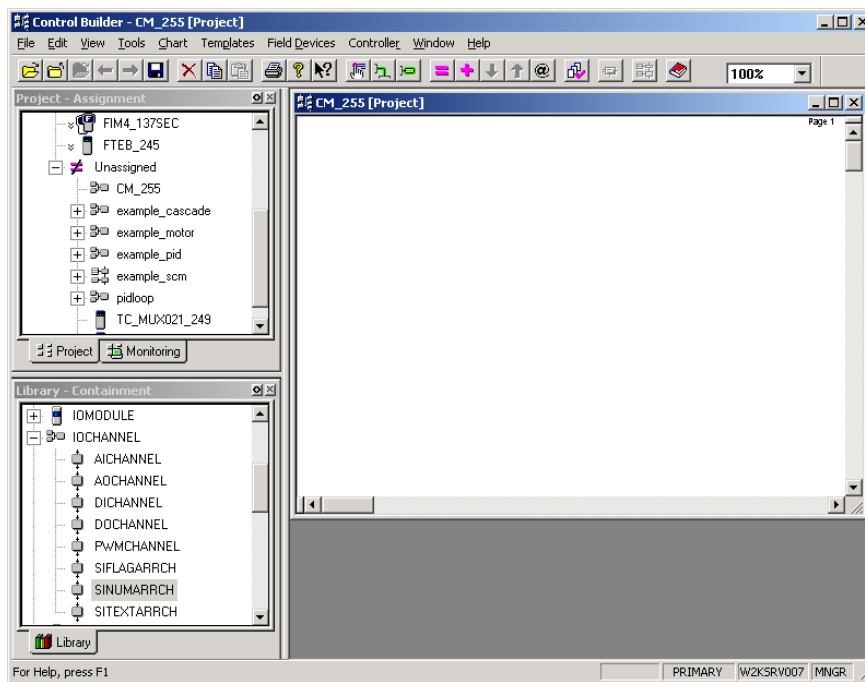

2. In the **Library** tab, scroll to the IOCHANNEL icon and click the plus sign to expand the tree.
3. Click and drag the icon for the SINUMARRCH block to the open CM in the Control Drawing to add the block to the CM, as shown in the following sample illustration.

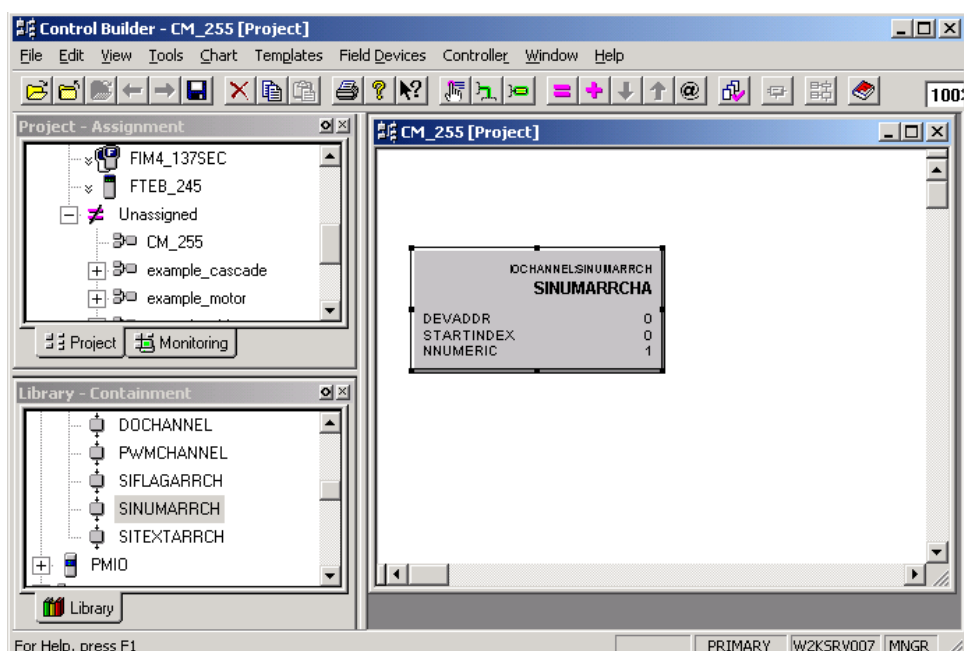

4. Double-click the SINUMARRCHA block to open its configuration parameters form.

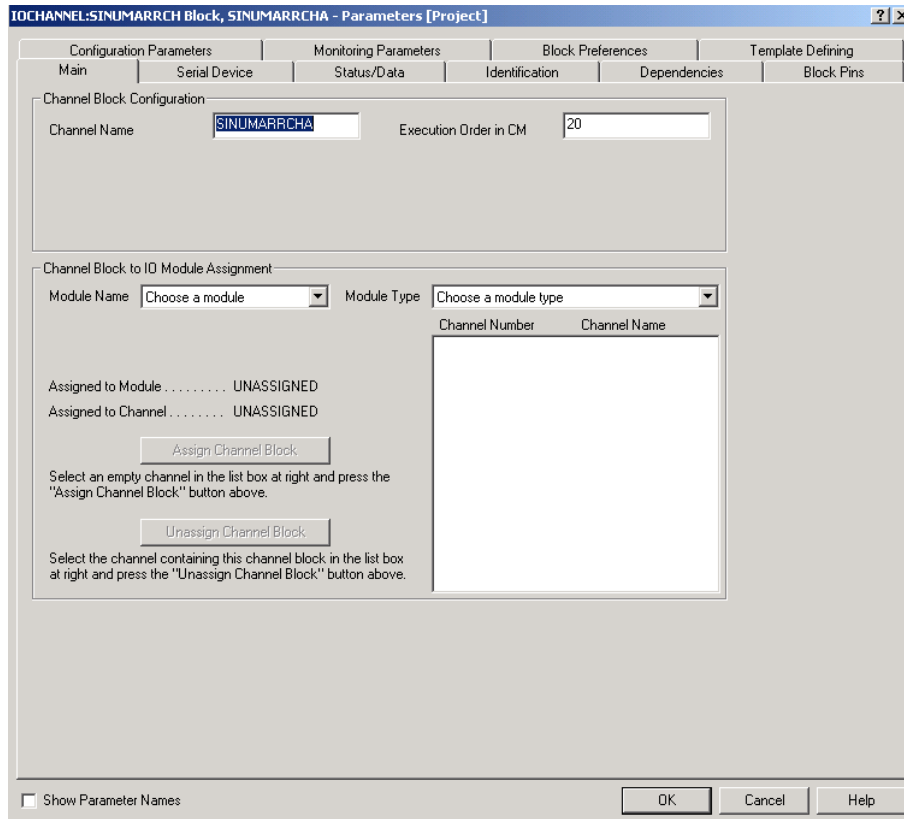

5. Accept the highlighted default **Channel Name** or key in a new one.
6. Double-click the **Execution Order in CM** box and key in the desired number in multiples of 10 to define the execution order of the block in the CM.
7. Click the down arrow in the **Module Name** box and select the SIM to be associated with this channel. Once the SIM is selected, the **Module Type** and **Channel Number** fields are automatically updated, as shown in the following sample illustration.

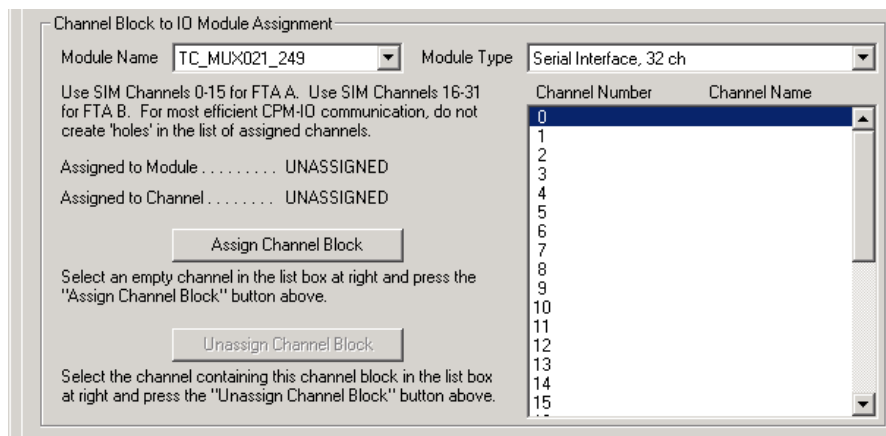

8. In the **Channel Number** list box, click the desired FTA channel number this channel block is to be assigned to. Channel 0 is the default selection.

Chapter 5 - SIM Configuration

- Click the **Assign Channel Block** button to assign this channel to the selected FTA channel number. The **Channel Name** field and the Assigned to ... fields are automatically updated, as shown in the following sample illustration.

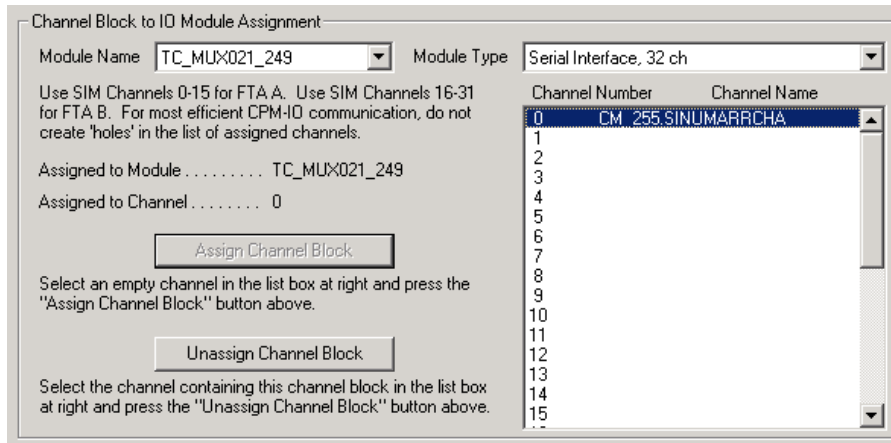

- Click the **Serial Device** tab to display it.

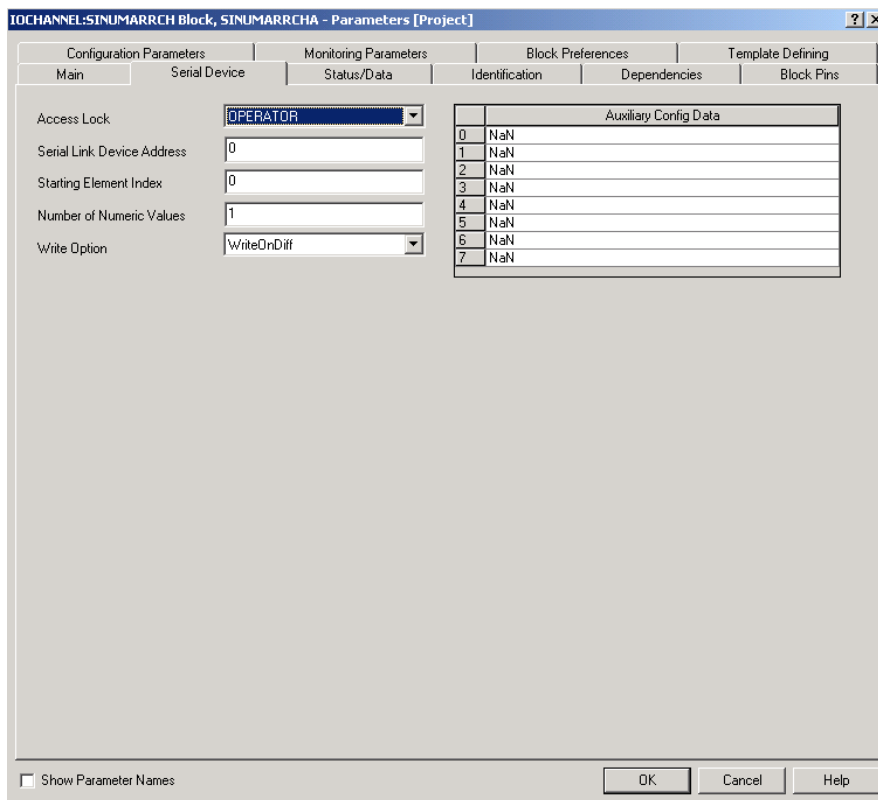

- Click the down arrow in the **Access Lock** box and select who can change the block's value or state based on signon privileges. Press the **Tab** key to move the cursor to the **Serial Link Device Address** box.
- Key in the address that identifies the serial link device connected to this FTA channel. Press the **Tab** key to move the cursor to the **Starting Element Index** box.

13. Key in the value to identify the start of the contiguous array in the serial device. See the Allen-Bradley Interface Reference or MODBUS Interface Reference section, depending on the communications interface protocol being used, for more information. Press the **Tab** key to move the cursor to the **Number of Numeric Values** box.
14. Key in the number that represents the number of numeric values in the array of data from the serial device.
15. Click the down arrow in the **Write Option** box and select how the Array Channel block will handle writes to its 'data' parameter.
16. Double-click the **0** row in the **Auxiliary Config Data** list box. Key in value to define communications interface for Allen-Bradley Interface or MODBUS Interface. The default value is NaN (Not a Number) if parameters are not being used with a specified interface. See the Allen-Bradley Interface Reference or MODBUS Interface Reference section, depending on the communications interface protocol being used, for more information
17. Repeat Step 17 for the other (1 to 7) rows in the **Auxiliary Config Data** list box, as applicable.
18. Click the **Identification** tab to display it
19. Use this tab to configure parameters associated with the licensed template option. See the *Control Building Guide* and/or the online help for more information.
20. Click the **Block Pins** tab to display it.
21. Use this tab to configure the pins you want to expose for this block. See the *Control Building Guide* and/or the online help for more information.
22. Click the **Configuration Parameters** tab to display it.
23. Use this tab to configure the parameters to be displayed on the block in the **Project** mode. See the *Control Building Guide* and/or the online help for more information.
24. Click the **Monitoring Parameters** tab to display it.
25. Use this tab to configure the parameters to be displayed on the block in the **Monitoring** mode. See the *Control Building Guide* and/or the online help for more information.
26. Click the **Block Preferences** tab to display it.
27. Use this tab to configure the viewing preferences for the block. See the *Control Building Guide* and/or the online help for more information.
28. If you have a template license, click the **Template Defining** tab to display it.
29. Use this tab to select which parameters are to be template defining. See the *Control Building Guide* and/or the online help for more information.
30. When you completed entering configuration data, click the **OK** button to close the configuration form and save the data.
31. This completes the procedure. Go to the next section.

## 5.3 Assigning SIM to Execution Environment

If you assign a SIM to a CEEC300 block, you must configure the name of the FTE Bridge block that represents the FTEB mounted in the Series A I/O chassis to identify the communications path to the SIM on its configuration form. The following illustration shows an excerpt of the FTE Bridge Name field that appears on the TC\_MUX021 Block configuration form when the SIM is assigned to a CEEC300 block.

---

## Chapter 5 - SIM Configuration

---

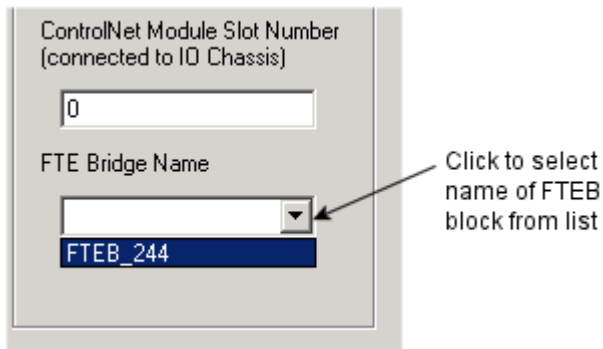

All illustrations used in the following procedure are for example purposes only.

### 5.3.1 Prerequisites

- You have started Configuration Studio and launched the Control Builder application.
- You have logged on with sufficient privileges to create control strategies using Control Builder.
- You have created a C200 and/or C300 Controller block in the **Project** tab.
- You have added a SIM block to the **Project** tab.

## 5.3.2 To assign SIM to CEE

1. On the **Edit** menu, click **Execution Environment Assignment**; or click the Execution

Environment Assignment button  on the toolbar to call up the **Execution Environment Assignment** dialog, as shown in the sample illustration below.

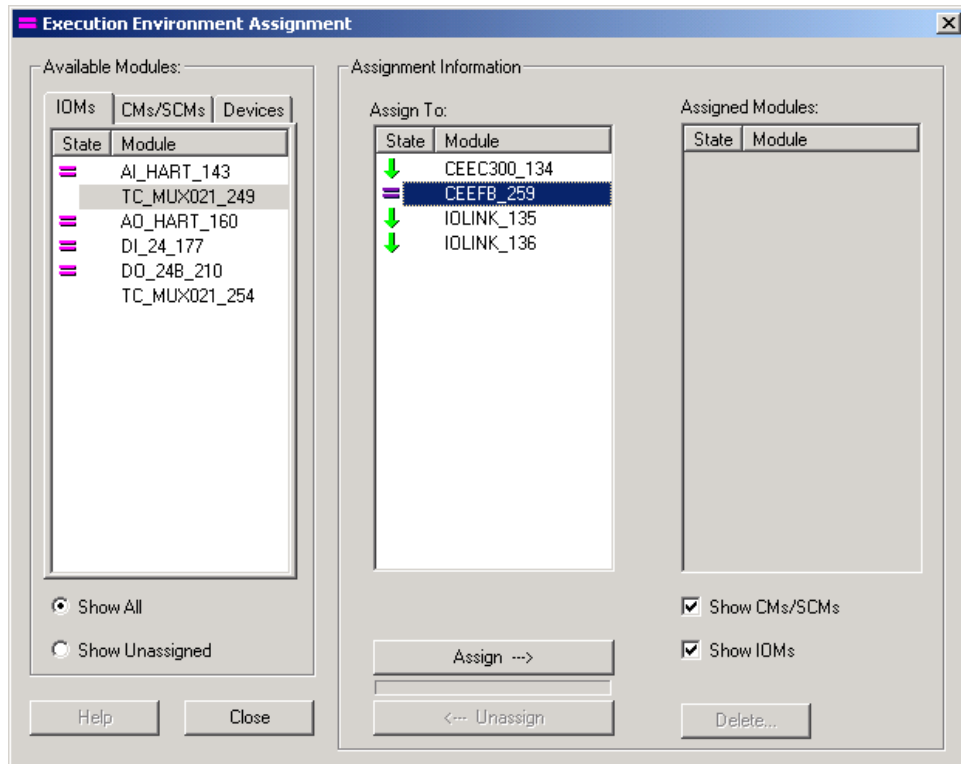

2. If the **IOMs** tab is not on display in the **Available modules** list box, click the tab to display it. Click the SIM module to be assigned to select it.
3. In the **Assign To** list box, click the CEE block that the SIM is to be assigned to select it.
4. Click the **Assign -->** button to assign the selected module to the given CEE block.
5. Check that the SIM block now appears in the **Assigned Modules** list box for the given CEE block, as shown in the sample illustration below.

Note that the equal symbol **=** prefix means that the block has been assigned and the down arrow symbol **↓** prefix means that the block has been loaded to the Controller.

## Chapter 5 - SIM Configuration

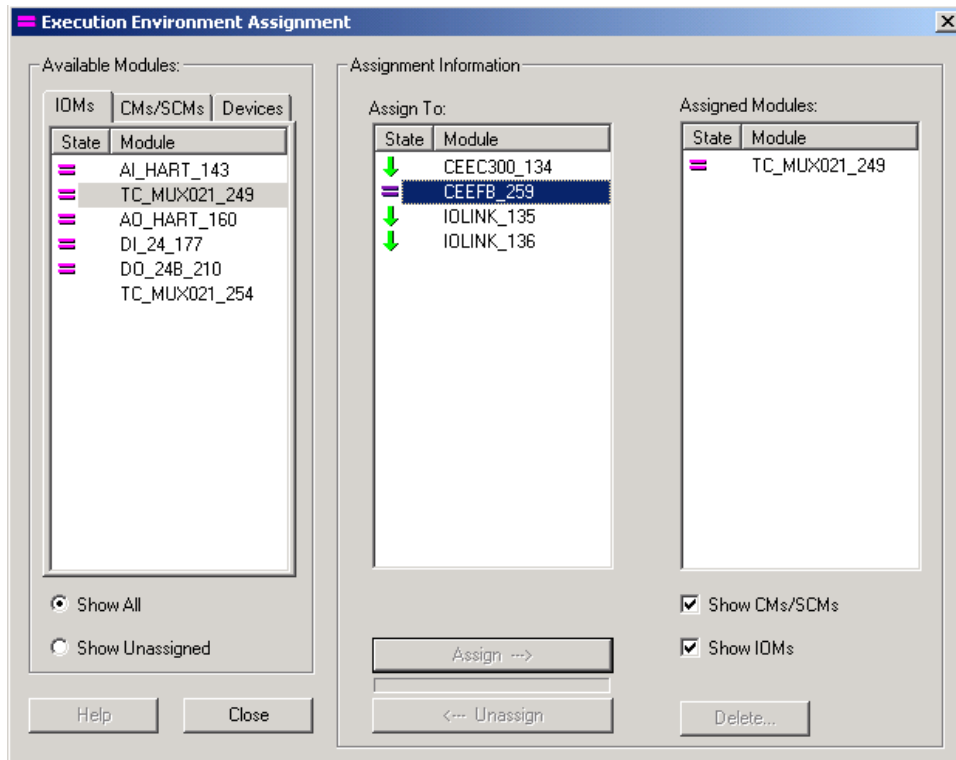

6. Click the **Close** button to exit the dialog and save the assignments.
7. This completes the procedure. Go to the next section.

## 5.4 Loading configuration data to the SIM

The following procedure is based on doing an initial load of a block from the **Project** tab. You can also initiate a reload of a block from the **Monitoring** tab.

All the illustrations used in the procedure are for example purposes only.

### CAUTION

The load operation is still an offline function. The Load Dialog box provides the ability to automatically inactivate a component during a load and then return the component to its active state. Do **not** use this automatic inactivate/activate function, if your process cannot tolerate the load disruption and consequent delay in activation. In this case, you must manually toggle the component state through the Monitoring tab in Control Builder.

### 5.4.1 Prerequisites

- You have started Configuration Studio and launched the Control Builder application.
- You have logged on with sufficient privileges to create control strategies using Control Builder.
- You have loaded the Controller and its execution environment.
- You have assigned the SIM block to the loaded Execution Environment

## 5.4.2 To load SIM block

1. In the **Project** tab, click the plus signs to expand the tree hierarchy for the Controller, CEE, and I/O icons, as required.

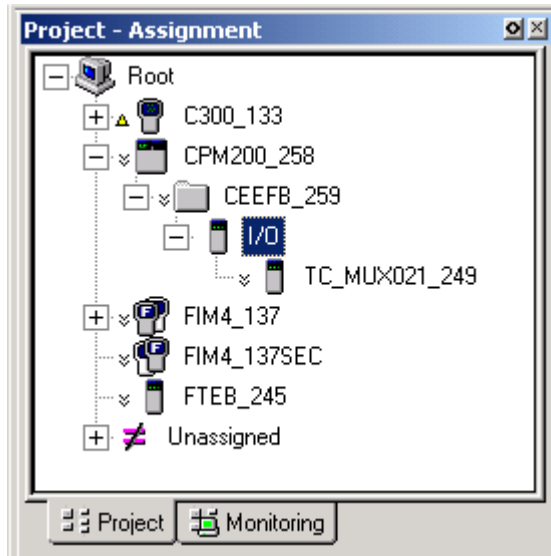

2. Right-click the SIM icon and select **Load** from the menu to call up the Load dialog.

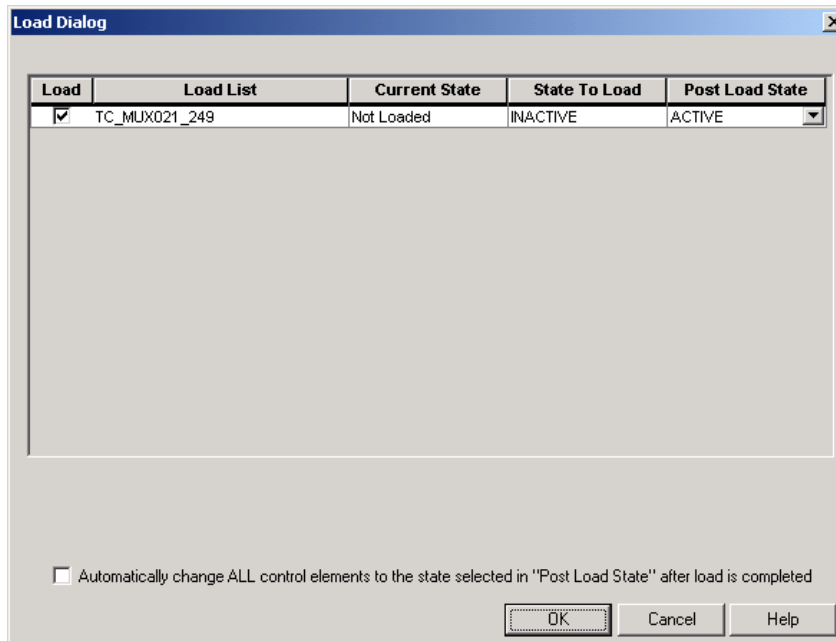

- a. Be sure the check box in the **Load** column is checked.
- b. Click the down arrow in the **Post Load State** column to select another state.
- c. Check the check box at the bottom of the dialog to automatically change the state of the SIM to the selected Post Load State after the load is completed.

## Chapter 5 - SIM Configuration

---

3. Click the **OK** button to initiate the load and track progress through the **Load Monitor** dialog.
4. After load completes, check that the SIM icon now appears in the **Monitoring** tab tree hierarchy.
5. This completes the procedure. Go to the next section.

CHAPTER

6

**SIM OPERATION**

- [SIM Front Panel Display and Indicators](#)
- [Monitoring Serial Interface Functions through Station Displays](#)
- [Monitoring Serial Interface Functions through Monitoring Tab in Control Builder](#)

**6.1 SIM Front Panel Display and Indicators**

As shown in the illustration below, the SIM has one four-character alphanumeric display and three two-color LEDs on its front panel. From left to right, the LEDs provide Channel A Activity, Channel B Activity, and module health status, respectively.

Figure 6.1 SIM front panel display and indicators

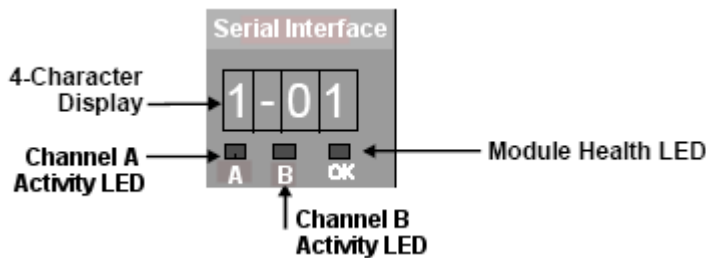

- [Typical startup, runtime, and firmware load SIM display indications](#)
- [Typical channel activity LED indications](#)
- [Typical health LED indications](#)

**6.1.1 Typical startup, runtime, and firmware load SIM display indications**

The following table lists some typical display indications and what they mean.

If Display Is ...	Then, It Means That ...
Tnnn	SIM is in its self-test mode and nnn equals the current test sequence number.
TEST	Factory Test Mode has either been entered on command or because the backplane test signal was asserted.
PASS	Completed Self-Test - attempting to execute Boot image.
ALIV	SIM is running without a personality image. You need to load the firmware to restore the personality image.
RDY	SIM is running but the personality image is shut down. You can load the firmware.
LOAD	SIM is running with an open loader connections. This usually indicates that a firmware download is in progress.

Chapter 6 - SIM Operation

If Display Is ...	Then, It Means That ...
<b>BOOT</b>	SIM has completed its selftest and is attempting to execute its personality image.
<b>Wait</b>	SIM is attempting to program flash ROM. (The Health LED is red during the actual programming.)
<b>Stop</b>	SIM is shutting down. This is a transitional state.
<b>OK</b>	SIM is running its personality image and will alternately display its channel states.
<b>A ok</b> <b>B ok</b>	Channel is operating normally, communicating with FTA, and FTA is communicating with attached device.
<b>Aerr</b> <b>Berr</b>	Channel cannot communicate with FTA.
<b>A sf</b> <b>B sf</b>	Channel can communicate with FTA but FTA is reporting a soft failure.
<b>Acfg</b> <b>Bcfg</b>	Channel is being configured. This is normally a transient display. If it stays on display, the configuration is bad.

### 6.1.2 Typical channel activity LED indications

If LED Is ...	Then, It Means That ...
<b>Off</b>	There is no channel activity.
<b>Flashing Green</b>	Channel transmit or receive is in progress, but not normal continuous communications.
<b>Brief Green Flash every 0.5 second</b>	FTA is not present or not communicating - a retry is performed every 0.5 second.
<b>Solid Green</b>	Normal continuous communications with FTA are in progress.

### 6.1.3 Typical health LED indications

If LED Is ...	Then, It Means That ...
<b>Off</b>	No power; significant fault.
<b>Solid Red</b>	<ul style="list-style-type: none"> <li>• During a load, it means programming the Flash ROM.</li> <li>• Selftest is in progress or failed - accompanied by a test number in the alphanumeric display, hardware fault, unrecoverable WDT timeout.</li> </ul>
<b>Flashing Red</b>	All I/O connections are lost, or fail state, running under software control.
<b>Alternating Red/Green</b>	SIM is in factory test mode.
<b>Solid Green</b>	SIM is OK - At least one I/O data connection is active.
<b>Flashing Green</b>	<ul style="list-style-type: none"> <li>• During a load, SIM is getting ready to program Flash ROM.</li> <li>• During run, no active I/O connection since power up.</li> </ul>

## 6.2 Monitoring Serial Interface Functions through Station Displays

- [About Using Station Detail displays](#)
- [About Using Station Event Summary display](#)

### 6.2.1 About Using Station Detail displays

The Experion Server Station application includes pre-configured Detail displays for the SIM

function blocks. These displays are the default entries for the Point Detail Page parameter on the Server Displays tab of the configuration form. Once you establish communications with a SIM you can begin monitoring the status of any component that has been loaded as part of a Control Strategy to an Experion Controller with points registered in the Experion Server. The Detail displays let you quickly view the component's current state, fault status, and pertinent configuration data.

## 6.2.2 About Using Station Event Summary display

Like the Detail displays, the Alarm and Event Summary displays support the integration of SIM generated notifications and events. It is integrated with Experion component data and is for the most part self-explanatory. Use this display to get a quick review of recent actions that have been initiated within the system.

## 6.3 Monitoring Serial Interface Functions through Monitoring Tab in Control Builder

- [Activating/inactivating SIM](#)
- [SIM block icon appearances](#)
- [Monitoring/Interacting with given component/block](#)

### 6.3.1 Activating/inactivating SIM

Use the following procedure to change the state of a SIM through the **Monitoring** tab in Control Builder.

Activating a SIM generates a state event change and resumes the module's normal periodic processing.

Inactivating a SIM generates a state event change; blocks channel access to flag, numeric, and string data from the SIM; and sets channel data to NaN, Off, and ' ', as well as setting associated statuses to Bad.

#### Prerequisites

- You have logged on with sufficient privileges to make changes in a control strategy.
- You have loaded a control strategy to the Controller and can view the SIM through the **Monitoring** tab of Control Builder.

#### To activate or inactivate a SIM





1. Right-click the SIM icon (green) and click **Inactivate > Selected Item(s)** on the menu Or right click the SIM icon (blue) and click the **Activate > Selected Item(s)** on the menu.
2. Click the **Yes** button to confirm the action in the **Change State** dialog.
3. Wait for SIM icon to turn blue/inactive Or Wait for SIM icon to turn green/active.  
This completes the procedure. Go to the next section.

### 6.3.2 SIM block icon appearances

The following table summarizes the various appearances that a SIM block icon in Control Builder can assume based on configuration, view, and current SIM operating state and status.

If Icon is . . .	Then, it represents . . .	And, Module State Is. . .
<b>Project Tab</b>		
	SIM configured for operation in Project.	N/A

Chapter 6 - SIM Operation

If Icon is . . .	Then, it represents . . .	And, Module State Is . . .
(gray)		
<b>Monitoring Tab</b>		
 (gray)	SIM is loaded, but not monitoring	N/A
 (blue)	SIM is inactive	Idle
 (green)	SIM is Active	Run
 (red/black exclamation)	SIM with communication failure	Offnet
 (red/red exclamation)	Failed SIM	Offnet

### 6.3.3 Monitoring/Interacting with given component/block

Once you download a Controller and its contents, you can use the **Monitoring** tab to interact with the components including the function blocks in the Control Module.

You simply double-click the desired component/block icon in the hierarchy tree menus under the Controller icon to call up the associated Configuration form or open the Control Module in the Control Drawing to double-click blocks contained in the CM. Click the given Configuration form tab to view the current status of the related block data. Both the SIM and CM function blocks must be active to view on-line data. The data can be viewed either by name or parameter reference by **not** checking or checking the **Show Parameter Names** check box at the bottom of each tab.

Please refer to the *Control Building Guide* sections in *On-Line Monitoring Using Control Builder* for detailed information:

- *Setting the CEE Inactive*
- *Changing Parameters while Monitoring*

## CHAPTER

## 7

## SIM MAINTENANCE

- [Periodic Checks](#)
- [Recommended Spare Parts](#)
- [SIM Removal and Installation Under Power](#)
- [Replacing Failed SIM T C- or TK-MUX021](#)
- [Replacing Failed Power Adapter TC-/TK-SMPD01 or TC-/TK-SMPC01](#)
- [Replacing Failed Serial Interface FTA](#)

## 7.1 Periodic Checks

The following table identifies checks that you should make periodically (every 3 to 6 months) to keep the SIM in good working condition.

Check . . .	Possible Corrective Action . . .
That all segments of the 4-character display and the light emitting diodes (LED) on SIM are working.	If segment or LED is not lit or has dimmed, you must replace the SIM, since front-panel indicators and LEDs are not field replaceable.
That all connections are secure.	Secure connections, as needed.
That cable insulation is not worn or cracked.	Replace cables, as required.
That SIM is secure.	Fully seat SIM in chassis.

## 7.2 Recommended Spare Parts

The following table provides a list of parts that you may want to keep on hand for backup, as applicable to your given application.

Part Name	Part Number	Description	Quantity per 10/100
SIM	TC- or TK-MUX021	Serial Interface Module	1/5
Power Adapter	TC- or TK-SMPD01	24 Vdc SIM FTA Power Adapter	1/2
	TC- or TK-SMPC01	85 to 265 Vac SIM FTA Power Adapter	1/2
Modbus FTA	MU-TSIM12	Limited Range Modbus FTA	1/2
	MU-TSIM13	Extended Range Modbus FTA	1/2
	MC-TSIM13		
Allen-Bradley FTA	MU-TSIA12	Allen-Bradley DF1 Modbus FTA	1/2

## 7.3 SIM Removal and Installation Under Power

Please review the Removal and Insertion Under Power (RIUP) Function Guidelines in the *Control*

*Hardware Installation Guide* before you RIUP any module.

## 7.4 Replacing Failed SIM T C- or TK-MUX021

Ensure that the system is offline or in a safe operating mode and power is removed from the chassis. Also ensure that you take ESD hazard precautions when handling the SIM. See the [SIM Installation Declarations](#) section for more information.

Use the following procedure as a guide for replacing a failed SIM.

### CAUTION

We recommend that you proceed with **extreme caution** whenever replacing any component in a control system. Be sure the system is offline or in a safe operating mode.

Component replacements may also require corresponding changes in the control strategy configuration through Control Builder, as well as downloading appropriate data to the replaced component.

### 7.4.1 Prerequisites

You have logged onto Control Builder with sufficient security level to make control strategy changes.

The SIM icon is red with red exclamation point in the **Monitoring** tab of Control Builder.

### 7.4.2 To replace a failed SIM

1. Unplug the SIM to Power Adapter cable assembly from the SIM.
2. Push in the top and bottom locking tabs on the SIM.

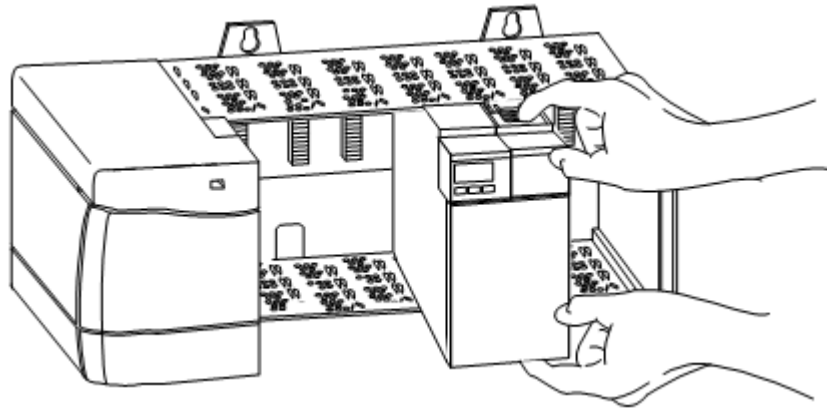

3. Pull the SIM out of the chassis.
4. Reverse Steps 1 to 3 to install the replacement SIM.
5. Check that the SIM passes its powerup self-test and assumes an OK operating condition.
6. If SIM display shows **ALIV**, see the [Upgrading SIM Firmware](#) section for more information.
7. Download the SIM block from the **Project** tab in Control Builder. See the [Loading configuration data to the SIM](#) for more information.
8. This completes the procedure. Resume normal operation.

## 7.5 Replacing Failed Power Adapter TC-/TK-SMPD01 or TC-/TK-SMPC01

Ensure that you take ESD hazard precautions when handling the SIM power adapter. See the [SIM Installation Declarations](#) section for more information.

Use the following procedure as guide to replace a failed SIM power adapter.

### 7.5.1 Prerequisites

- You have inactivated the SIM through the **Monitoring** tab in Control Builder.
- You have reviewed the previous **CAUTION** note.
- You have logged onto Control Builder with sufficient security level to activate/inactivate components.

### 7.5.2 To replace SIM power adapter

1. Turn Off the power source.
2. Remove power cable leads from ac or dc power connector.
3. Disconnect the SIM-to-Power Adapter, and the Power Adapter-to-FTA cables.
4. Remove the screws that hold the Power Adapter to the surface. Be sure you are holding the Power Adapter when you remove the last screw Or Grasp both rail mount adapters on the tapered side and pull forward slightly to pop the Power Adapter off the DIN rail. Be sure you hold onto the Power Adapter, so it does not fall on the floor.
5. Reverse Steps 2 to 4 to mount the replacement power adapter.
6. Turn On the power source
7. This completes the procedure. Activate the SIM and resume normal operation.

## 7.6 Replacing Failed Serial Interface FTA

Refer to the previous applicable Modbus or Allen-Bradley FTA installation data and just reverse the instructions to remove the failed FTA and follow them to install the replacement FTA.

## CHAPTER

## 8

## SIM TROUBLESHOOTING

This section offers some general data about fault classifications, initial checks, and SIM self-test diagnostic codes that may help you isolate the cause of a problem.

If you have observed a specific symptom and/or identified an error code, go to the Fixing Common Problems section to see if you can find a matching topic.

- [Fault Classifications](#)
- [Initial Checks](#)
- [SIM Self-Test Diagnostic Codes](#)
- [Fixing Common Problems](#)
- [Getting Further Assistance](#)

## 8.1 Fault Classifications

The following table lists some possible ways for classifying faults along with some identifying characteristics.

Fault Classification	Characteristics
<i>Hard Failure</i>	<p>Failure detected by hardware; operation cannot continue. If the fault does not prevent software processing the problem, the affected node will be rebooted under software control into the FAIL State.</p> <ul style="list-style-type: none"> <li>• If failure occurs on Primary node, it triggers a switchover to synchronized Secondary node.</li> <li>• If failure occurs on Secondary node, it results in loss of synchronization and reduced availability until the problem is resolved.</li> <li>• If failure occurs on non-redundant node, it results in loss of control and loss of view.</li> </ul>
<i>Severe Failure</i>	<p>Failure detected by software; operation cannot continue. The affected node will be rebooted under software control into the FAIL State.</p> <p>The failure scenarios are as listed in the row above for the Hard Failure.</p>
<i>Soft Failure</i>	<p>Failure detected by software; operation continues with full control and full view. Soft failures are alarmed to the operator. FTE will be monitored by the FTE System Management Tool.</p> <ul style="list-style-type: none"> <li>• If failure occurs on Primary node, it does not trigger a switchover to synchronized Secondary node.</li> <li>• If failure occurs on Secondary node, it does not result in loss of synchronization.</li> <li>• If failure occurs on non-redundant node, it does not result in loss of control and loss of view.</li> </ul>
<i>Installation/Startup Failure</i>	<p>Detected by software. Node may not become operational.</p> <ul style="list-style-type: none"> <li>• This failure does not apply to synchronized Primary node, since installation and startup must be successful to reach synchronized Primary state.</li> </ul>

Fault Classification	Characteristics
	<ul style="list-style-type: none"> <li>• If failure occurs on Secondary node, it results in the inability to complete the initial synchronization and to view the node on the network.</li> <li>• If failure occurs on non-redundant node, it results in the inability to commence control and to view the node on the network.</li> </ul>
Communication	Communication errors between peer nodes and/or I/O devices, including Fault Tolerant Ethernet Bridge (FTEB), do not cause any node state change.

## 8.2 Initial Checks

This section offers some checks that you can make to help isolate the problem. The checks are arranged in no particular order.

- [Checking Control Builder error code reference](#)
- [Checking front panel display and LEDs](#)
- [Viewing error codes through serial interface block form](#)
- [Viewing flash log](#)
- [Viewing release information log](#)
- [Viewing trace log](#)
- [Checking version and revision log](#)
- [Checking server point build log](#)
- [Using NetworkTools to view SIM statistic data](#)
- [Checking server point build error log](#)
- [Checking error log](#)
- [Using NetworkTools to capture chassis information](#)

### 8.2.1 Checking Control Builder error code reference

An indication of a problem may be in the form of an error dialog that includes an error message and possibly an error code in Control Builder.

The syntax for a typical Control Builder error message is as follows:

Connection to device is not open EPKS\_E\_CL\_NOCONN(6L.101.3326)

In this syntax, the error code is the last four digits in the message or **3326**.

Please refer to the *Control Builder Error Codes Reference* book for applicable error code information.

### 8.2.2 Checking front panel display and LEDs

Check the SIM 4-character display and light emitting diodes (LEDs) indications and compare results with data in the [SIM Front Panel Display and Indicators](#) section of this book.

### 8.2.3 Viewing error codes through serial interface block form

You can view the current Detailed Error Code (ERRCODE) parameter field value on the serial interface block's configuration form **Status/Data** tab through the **Monitoring** tab in Control Builder. The ERRCODE value may also be visible on the face of the serial interface block in the contained Control Module in the **Monitoring** mode. Refer to the *Error Messages* section in the [Error messages when Array Channel Block is configured for Generic MODBUS Interface](#) or the [Error messages when Array Channel Block is configured for Allen-Bradley Interface](#) for more information.

### 8.2.4 Viewing flash log

The Flash.txt log provides a list of firmware updates that have been initiated.

To view the log, navigate to this file location on the server: C:\Program Files\Honeywell\Experion PKS\Engineering Tools\system\bin\Flash.txt.

## 8.2.5 Viewing release information log

The ReleaseInfo.txt log provides a list of Experion software releases that have been installed on the computer.

To view the log, navigate to this file location on the server: C:\Program Files\Honeywell\Experion PKS\Engineering Tools\system\bin\ReleaseInfo.txt.

## 8.2.6 Viewing trace log

The TraceLogRs.txt log provides a list of definitions for strings associated with *breadcrumbs* data for given hardware components. The *breadcrumbs* provide a way to trace operations leading up to an event.

To view the log, navigate to this file location on the server: C:\Program Files\Honeywell\Experion PKS\Engineering Tools\system\bin\TraceLogRs.txt.

## 8.2.7 Checking version and revision log

The ver\_rev.txt log provides a list of components by model number with software version/revision along with compatible Experion software release(s).

To check the log, navigate to this file location on the server: C:\Program Files\Honeywell\Experion PKS\Engineering Tools\system\bin\ver\_rev.txt.

## 8.2.8 Checking server point build log

The SvrPtBld\_servername.txt log provides list of process (CB) points built in the server database.

To check the log, navigate to this file location on the server: C:\Program Files\Honeywell\Experion PKS\Engineering Tools\temp\SvrPtBld\_servername.txt.

## 8.2.9 Using NetworkTools to view SIM statistic data

Please refer to the *Viewing SIM statistics in NetworkTools* section in the *Control Hardware Troubleshooting and Maintenance Guide* for more information.

The Network Tools (NTools) application lets you view additional SIM diagnostic information by selecting the SIM Module in its chassis view and making the appropriate **Device** menu selection. Keep the following considerations in mind.

- An informational string is returned by the FTA to help diagnose the cause of soft failures. See the Allen-Bradley Interface [Error messages when Array Channel Block is configured for Allen-Bradley Interface](#) or MODBUS interface [Error messages when Array Channel Block is configured for Generic MODBUS Interface](#) for more information.
- The statistics are a continuously updating display of the one-second-sampled, 15-second running average statistics, collected by the SIM.
- When Control Module Array Channel block communication has failed and all the failed devices have been set inactive, the NTools SIM status display will show the FTA revision and the FTA communication settings.

If every Control Module Array Channel block connected to an FTA is set inactive, the NTools SIM status display will show the FTA revision and the text '**No Array Points are configured to this FTA**'.

## 8.2.10 Checking server point build error log

The svrptblderr\_servername.txt log provides list of any errors associated with process (CB) points built in the server database

To check the log, navigate to this file location on the server: C:\Program Files\Honeywell\Experion PKS\Engineering Tools\temp\svrptblderr\_servername.txt.

## Chapter 8 - SIM Troubleshooting

### 8.2.11 Checking error log

The Errlog\_n.txt log provides a running list of Control Builder detected errors in chronological order. The n represents any number that is assigned to the most recent log.

To check the log, navigate to this file location on the server: C:\ProgramData\Honeywell\Experion PKS\ErrLog\_n.txt.

Prior to R400, the Errlog\_n.txt file was stored in the following location on the server: C:\Documents and Settings\All Users\Application Data\Honeywell\Experion PKS\Errlog\_n.txt.

### 8.2.12 Using NetworkTools to capture chassis information

Please refer to the *Capturing chassis information using NetworkTools* section in the *Control Hardware Troubleshooting and Maintenance Guide* for more information.

## 8.3 SIM Self-Test Diagnostic Codes

The following table lists the self-test diagnostic codes that the SIM steps through upon power up. If a test fails, you must replace the SIM.

The LED indications are as follows during the test.

- The Module Health LED turns Red during the self-test and then Green upon successful completion of the self-test.
- The Channel Activity LEDs turn Red until the completion of the Alphanumeric Display Test and then Green until the completion of the ROM test.

The Test Sequence Numbers (Codes) are first sent to the factory test port and then to the alphanumeric display.

Test Code (s)	Target Device	Failure Modes	Function
T000	Alphanumeric Display and LED Test	Hardware control registers are not writable, CPU PLD	Steps through horizontal/vertical bars, and then flashes all segments of the display through stages of brightness. For this test to work, CPU, Flash ROM, address bus, data bus, and some I/O ports must be working.  The firmware version is briefly displayed after this test.
T001	CPU Type and Version Check	Wrong CPU chip installed	This test is done before the ROM tests, because a wrong CPU could appear to work, but might fail timing tests. The CPU version is also displayed as E40+ or E41+ for 630e Rev 4.0 or 4.1, 100 MHz. Or, R for 603r, 150 MHz.
T010	Flash ROM Parity Scan	Flash chip	For each ROM line (8 bytes) of the 1 MB boot image area, the data is read and the expected parity is computed and compared with the actual parity. The test is timed.
T011	Flash ROM Parity Scan Time	Instruction Cache, MEM PLD wait states	The time needed to perform the above test is checked for reasonability. This test detects 603 Instruction Cache failure and/or ROM wait state problems.
T012	Flash ROM Checksum	Flash chip	The checksum of the boot personality in ROM is computed and verified.
T013	Flash ROM Loader Checksum	Flash chip	The checksum of the boot personality's Flash ROM loader is computed and verified.
T015	XILINX DRAM Controller ASIC Ready Check	Hardware Status Register chips, XILINX	This bit is asserted if the XILINX did not power up properly.
T016	XILINX DRAM	MEM PLD	The XILINX configuration file is written one bit at a time to the

## Chapter 8 - SIM Troubleshooting

Test Code (s)	Target Device	Failure Modes	Function
	Controller ASIC Load		chip.
T017	XILINX DRAM Controller ASIC Error Check	Hardware Status Register chips, XILINX, MEM PLD	This bit is asserted if the XILINX did not configure properly.
T018	XILINX DRAM Controller ASIC Read-Back Verify	XILINX, MEM PLD	The XILINX configuration file is read back 32 bits at a time, and compared to the image in ROM. A read-back mask is used to determine which bits of the stream are not to be compared for one reason or another.
T020	RAM Path	RAM, XILINX, buffers, MEM PLD	Verifies that RAM can be read/written as 32-bit words. This is the first and simplest way to access RAM. It is also the only way to know if the XILINX was configured properly.
T021	RAM Parity Path	RAM, XILINX, buffers, MEM PLD	Writes two 8-byte patterns and verifies that parity byte was set correctly, even and odd.
T022	RAM Word Access	RAM, XILINX, buffers, MEM PLD	Verifies that word patterns can be written and read including three cases of miss-aligned transfer.
T023	RAM Byte Access	RAM, XILINX, buffers, MEM PLD	Verifies that writing a string of 8 bytes can be read back as two correct words, and as 8 bytes.
T024	RAM Half Access	RAM, XILINX, buffers, MEM PLD	Verifies that half words can be read.
T025	RAM Byte Write	RAM, XILINX, buffers, MEM PLD	Verifies that bytes can be written correctly.
T026	RAM Half Write	RAM, XILINX, buffers, MEM PLD	Verifies that half words can be written correctly.
T027	RAM Half Align	RAM, XILINX, buffers, MEM PLD	Verifies that half-words can be written and ready when miss-aligned.
T028	RAM Word Align	RAM, XILINX, buffers, MEM PLD	Verifies that words can be written and ready when miss-aligned.
T029	RAM Double Access	RAM, XILINX, buffers, MEM PLD	Verifies that the floating point unit can write and read a double-word value, and the same value is correctly stored as two words.
T030	EDAC Correction	RAM, XILINX, buffers, MEM PLD	Verifies that any single-bit error can both be detected and corrected, in data or check bits, in high or low word. One bit at a time is changed and walked through one line of RAM.

## Chapter 8 - SIM Troubleshooting

Test Code (s)	Target Device	Failure Modes	Function
T031	EDAC Error Test	RAM, XILINX, buffers, MEM PLD	Verifies that a double-bit error can be detected, in both high and low word.
T032	Stuck Machine Check Interrupt	Hardware Status Register chips, CPU PLD, MEM PLD	After verifying that no machine check source is active in the Hardware Status Register, unmask the exception. No interrupt is expected.
T033	Data Parity Interrupt	Parity buffers, parity circuit	Verify that the data parity error detection is working by enabling data parity checking and the machine check exception, then walking through an area of ROM which has been programmed with bad parity. There are eight 8-byte lines, each with a parity error in a different byte, such that all byte lanes are covered.
T034	RAM Parity Sweep	Destructive RAM Test	The RAM is read two words at a time until end or until a multiple-bit error is detected. Single bit errors are counted, and written back for correction. Parity errors (SRAM) or Multi-bit Errors (DRAM) force destructive testing in RAM.
T035	RAM Single-Bit Error Threshold Test	RAM self-refresh control very high temp	The number of single-bit errors is compared against a threshold. High temperatures may cause a number of single-bit errors.
T036	RAM Parity Sweep Time	Instruction Cache, MEM PLD wait states	The time needed to perform the above test is checked for reasonability, using the PPC 630 decremented. This test detects 603 Instruction Cache failure and/or RAM wait-state problems. Note that the time is not measured (zero) if a parity error / Multi-bit Error is detected and memory is flushed.
T037	EDAC Interrupt	XILINX chip, Hardware Status Register chips, MEM PLD, CPU PLD	Verifies that a double-bit error will generate the correct machine check exception.
T040	RAM Memory Retention Test	Battery low	The magic numbers are checked to see if the data in RAM may still be valid. In the absence of parity errors, RAM is considered valid at the boot level. It passes test, bumps power cycle counter and skips destructive test and flush.
T041	RAM Destructive Pattern Test	XILINX, RAM chip, MEM PLD	Checks address and data lines by writing a non-repeating pattern over the whole memory, then verifying it. Runs with data parity enabled and fatal. Two starting patterns are used for better coverage.
T042	Flush RAM Data Zeros	XILINX, RAM chip, MEM PLD	Write zeros to all locations and verify. Data parity is enabled during this test. Runs with data parity enabled and fatal.
T043	Flush RAM Parity Ones	RAM chip, XILINX, Parity/check bit buffers	Verify that Flush RAM Data Zeros test forced parity byte to ones (check bits to correct value). Data parity disabled during this test, but enabled permanently after the test completes. Runs with data parity disabled. Sets magic number to show memory is initialized.
T050	CPU I-Cache Active Test		Compare how many times a loop runs in one clock tick with I-Cache disabled and enabled.
T055	CPU D-Cache Active Test	CPU	Enable cache and execute a RAM write/verify loop. Verify that it runs faster than it would if the cache were broken or disabled.

## Chapter 8 - SIM Troubleshooting

Test Code (s)	Target Device	Failure Modes	Function
			Flush/disable cache and verify that the data was written to RAM correctly. Only uses the memory test area, so just shows that the data cache is enabled and at least partially functional.
T056	CPU D-Cache Function Test	CPU	The checksum of the boot code is repeated with Data Cache enabled. The test is timed. If the data cache is not working properly, the checksum will fail or the test will take too long.
T060	Hardware Status Register Access Test	Hardware Status Register chips, CPU PLD	Verifies that the Hardware Status Register appears to be readable without generating a machine check exception.
T062	Hardware Status Register DC FAIL Test	Backplane, P/S	Verifies that the DC FAIL/SRESET status is not asserted.
T064	Hardware Status Register ICP_INT Test	IC PASIC	Verifies that the ICP_INT status is not asserted.
T065	Hardware Status Register DEV_INT Test	Dev Card DUART, Dev Card PLD, CPU PLD	Verifies that the DEV_INT (Interrupt from development board) status is not asserted.
T066	Hardware Status Register MEM_INT Test	XILINX, MEM PLD	Verifies that the MEM_INT (interrupt from memory board) status is not asserted.
T067	Hardware Status Register SYS_FAIL Test	CUP PLD, backplane, other modules	Verifies that the SYS_FAIL status is not asserted for longer than a specified period, to accommodate other module's tests.
T068	Hardware Status Watchdog Timer Timeout Pending Test	PLD, WDT chip	Verifies that the WDT_PENDING status is not asserted.
T069	Hardware Status Register FTA_INT Test	DUART	Verifies that the FTA DUART interrupt status is not asserted.
T070	Hardware Status Register ICP_FAULT Test	ICP ASIC	Verifies that the ICP-FAULT status is not asserted. This would indicate that the IC PASIC had failed to come out of reset.
T071	IC PASIC Release and Stuck Interrupt Test	ICP ASIC	Enables interrupts to make sure that there is no interrupt stuck in the asserted state. Because the Hardware Status Register has been tested for potential interrupt sources, no interrupt is expected.
T072	SYS_FAIL Assert Test	CPU PLD, backplane, other modules	Verifies that SYS_FAIL system controls assert and de-assert the SYS_FAIL condition. Uses timeouts to prevent conflicts with other modules under test on the same backplane. No SYS_FAIL interrupt test. This test will fail if another module leaves STS_FAIL asserted.

## Chapter 8 - SIM Troubleshooting

Test Code (s)	Target Device	Failure Modes	Function
T073	Watchdog Timer Test	CPU PLD, WDT chip, ICP ASIC, ICP Oscillator	Verifies that the WDT does not expire when hit for 500 msec, based on Hardware Status Register and interrupt. Uses the WDT Test mode to show that the WDT will time out and generate an SMI interrupt in more than 195 msec but less than 210 msec. The interrupt routine disables WDT Test Mode to clear the interrupt. Disables WDT after test.
T080	FTA DUART Register Access Test	CPU PLD	Verifies that the DUART can be initialized.
T081	FTA DUART Clock Compare Test	DUART Crystal	Check the DUART clock against the CPU timebase register to make sure they are running at the same relative rates. The test is run for 2048 DUART ticks (8.8888 msec) which corresponds to 55555 CPU ticks +/- 54.
T082	FTA DUART Interrupt Test	CPU PLD	Verifies that the DUART can generate an interrupt. The counter which had expired from the previous test is used. The interrupt is verified in the DUART ISR, then enabled through the DUART IMR and verified in the Hardware Status Register; finally exceptions are enabled to make sure that the interrupt occurs.
T083	FTA DUART Channel A Transceiver and Loopback Test	Transceivers	Verifies that data cannot be transmitted or received if either transceiver is disabled, but data can be transmitted and received when both are enabled.
T084	FTA DUART Channel B Transceiver and Loopback Test	Transceivers	Verifies that data cannot be transmitted or received if either transceiver is disabled, but data can be transmitted and received when both are enabled.
T085	FTA Local A Enable	Transceivers	Verifies that transmitter can be enabled.
T086	FTA Local B Enable	Transceivers	Verifies that transmitter can be enabled.
T100	ICP Shared RAM Destructive Pattern Test	Shared RAM chip, buffers, arbitration	Checks address and data lines by writing a non-repeating pattern over the whole memory, then verifying it. Runs with data parity enabled and fatal. Two starting patterns are used for better coverage.
T101	ICP Shared RAM Destructive Pattern Parity Interrupt Check	Shared RAM chip, buffers, arbitration	Verify that 603 data parity error did not occur during previous test. Runs with data parity enabled and fatal.
T102	ICP Shared RAM Initialization to Force Correct Odd Parity	Shared RAM chip, buffers, arbitration	Verified. This must be done before writing to the ASIC control registers. Runs with data parity enabled and fatal.
T111	ICP ASIC Register Access Test	ICP ASIC, ASIC-RAM I/F	The hardware setup parameters having been written to the ASIC some time earlier, access to the ICP ASIC registers is verified, and the error register is verified as zero. The ECHO_REV operation is used to make the ASIC write its version register to a designated location in Shared RAM. This value is saved in RAM. The rest of Shared RAM is verified to make sure that only the designated location was written.

Test Code (s)	Target Device	Failure Modes	Function
T112	IC PASIC Unique Address Echo Test	IC PASIC, ASIC-RAM I/F	Correct access to the ICP shared RAM from the ASIC is verified through the Echo Test, by asking the ASIC to write each location's address at that address. This test is performed once for the address and once for the complement of the address. Coverage is not 100% because only the 17 LS address bits are supported by ASIC.
T113	ICP Bus Lock Test	Bus lock or arbitration circuit (CPU PLD) ICP ASIC	Verify that the IC PASIC can be locked out of its Shared RAM by the 603. This is accomplished with the ASIC Echo_REV Test by: locking the bus, telling the ASIC to write to a specified address, looking at the address, unlocking the bus, and looking at the address to see that it changed and the correct data was written.
T114	ICP Clock Run Test	IC PASIC Oscillator	Verifies that ICP clock is running.
T115	ICP Clock Compare Test	603 Oscillator, ICP ASIC Oscillator	Check the ASIC clock against the 603 clock to make sure they are running at the same relative rates. The IC PASIC read timer command is used to write the Internal Timer to shared RAM where it is read by the 603. The test is run for 20 msec and +/- 0.016 msec error is allowed at this time.
T116	ICP ASIC Interrupt Test	Hardware Status Register chips, ICP ASIC	The IC PASIC timer interrupt is enabled, along with the CPU external interrupt, to see if the interrupt generation and recognition works and the Hardware Status Register ICP_INT is asserted. The ASIC timer is disabled, and the CPU interrupt inhibited, after the test.
T130	Personality Parity Check	No Personality, bad personality load	A parity interrupt scan is performed of the 3 MB personality area.
T131	Personality Area Erase	Bad flash chip	If the previous test indicated a parity error, the 3 MB personality are is erased and verified.
T132	Personality Checksum	Bad personality load	If the previous test indicated no parity error, and a personality is present, the personality checksum is verified. If no errors, a key is written in RAM to indicate that the personality is valid.
T255	PCM Signals End of Self-Test		The Module Health LED turns Green. Depending on various state flags and whether RAM was flushed, self-test will exit to the Alive/Fail executive or start the personality. Displays BOOT when starting the personality and PASS when starting the Alive executive.

## 8.4 Fixing Common Problems

This section identifies some common problems and describes how you might fix them.

- [Loss of power](#)
- [Poweron Self-Test Fault](#)
- [Fatal ECC error](#)
- [Background Diagnostic failure](#)

### 8.4.1 Loss of power

The power supply has failed or the main power source has been shut down or is experiencing a *brownout* or *blackout* condition.

#### Diagnostic check

## Chapter 8 - SIM Troubleshooting

---

- The 4-character display and LEDs on the SIM are off.
- In the **Monitoring** tab, the SIM icon turns red.

### Cause

Main power source has been disconnected or shut down either manually or temporarily by *brownout* or *blackout* condition.

### Solution

Reconnect the main power source or turn it On or wait for temporary *brownout* or *blackout* condition to pass.

### Cause

The 24 Vdc or 120/240 Vac chassis power supply failed or power cable has been disconnected or failed.

### Solution

Replace the chassis power supply or reconnect/replace the power cable.

## 8.4.2 Poweron Self-Test Fault

The SIM poweron selftest has detected a fault.

### Diagnostic check

A self-test diagnostic code remains on display and the poweron selftest does not continue.

### Cause

The SIM poweron selftest has detected a failure that does not allow operation to continue.

### Solution

Try cycling power to the SIM. Replace the SIM, if fault persists. See [Replacing Failed SIM T C- or TK-MUX021](#) for details.

## 8.4.3 Fatal ECC error

The SIM software has detected a fatal Error Checking and Correction (ECC) condition that can be a multiple-bit error or excessive single bit errors in main Random Access memory (RAM).

### Diagnostic check

- The 4-character display on the SIM displays FAIL.
- In the **Monitoring** tab, the SIM icon turns red.

### Cause

The SIM software has detected a failure that does not allow operation to continue. There can be many causes for a failure including hardware, use the NetworkTools function to capture a crash block for the device to determine the possible cause before proceeding.

## Solution

Try cycling power to the SIM. If error persists, replace the SIM. See [Replacing Failed SIM T C- or TK-MUX021](#) for details.

Check the Trace log for breadcrumbs that occurred prior to the event. See [Viewing trace log](#) and [Using NetworkTools to capture chassis information](#) for more information. Provide the results of the trace log to our Technical Assistance Center (TAC) for analysis.

## 8.4.4 Background Diagnostic failure

The SIM detects failure in system integrity checks, such as Watch Dog Timer (WDT), error detection circuits, readback, microprocessor static configuration registers, and Read Only Memory (ROM) checksum.

### Diagnostic check

- The 4-character display on the SIM displays FAIL.
- In the **Monitoring** tab, the SIM icon turns red.

### Cause

The SIM software has detected a background diagnostic failure that does not allow operation to continue.

### Solution

Try cycling power to the SIM. If error persists, replace the SIM. See [Replacing Failed SIM T C- or TK-MUX021](#) for details.

Check the Trace log for breadcrumbs that occurred prior to the event. See [Viewing trace log](#) and [Using NetworkTools to capture chassis information](#) for more information. Provide the results of the trace log to our Technical Assistance Center (TAC) for analysis.

## 8.5 Getting Further Assistance

- [Other troubleshooting sources](#)
- [Guidelines for requesting support](#)

### 8.5.1 Other troubleshooting sources

The following table lists other documents and sections that contain troubleshooting information for other Experion subsystems.

Document/Section	Comments
Experion Rxxx > Reference	There is a separate interface reference for each type of controller other than the Process Controller; for example, the <i>ASEA Interface Reference</i> .  Most of these references contain an interface-specific troubleshooting section.
Experion Rxxx > Reference > Control Builder Error Codes Reference	Describes error codes generated from within Control Builder.
Experion Rxxx > Troubleshooting and Maintenance > Control Hardware Troubleshooting and Maintenance Guide	The main repository for troubleshooting, maintenance and repair of Process Controllers.

## Chapter 8 - SIM Troubleshooting

Document/Section	Comments
Experion Rxxx > Configuration > DeviceNet Implementation Guide > Troubleshooting DeviceNet Status Failures	Describes error codes generated from DeviceNet Interface Board.
Experion Rxxx > Installation and Upgrades > Fault Tolerant Ethernet Bridge Implementation Guide > Service > Troubleshooting	Troubleshooting FTE bridges.
Experion Rxxx > Installation and Upgrades > Fault Tolerant Ethernet Installation and Service Guide > Troubleshooting FTE Nodes	Troubleshooting FTE nodes.
Experion Rxxx > Reference > Honeywell TDC 3000 Data Hiway Interface Reference > TDC error codes and Troubleshooting	Troubleshooting TDC 3000 Hiway problems.
Experion Rxxx > Configuration > Qualification and Version Control System User Guide > QVCS Troubleshooting	Troubleshooting QVCS.
Experion Rxxx > Operations > SafeView User's Guide > Appendix D - SafeView Error Messages	Describes the meaning of SafeView configuration errors.
Experion Rxxx > Reference > Server Scripting Reference > Server scripting error messages	Describes the meaning of error messages in the server log specific to server scripting.
Experion Rxxx > Reference > System Management Configuration Guide > Troubleshooting System Management	Describes the meaning of System Management Configuration errors.
Experion Rxxx > Reference > System Management Configuration Guide > Troubleshooting SES	Describes the meaning of SES Configuration errors.
Experion Rxxx > Reference > System Management Configuration Guide > Troubleshooting SPS	Describes the meaning of SPS Configuration errors.
Experion Rxxx > Planning and Design > Planning, Installation, and Service for WS360	Troubleshooting workstation nodes used in Experion and TPN.

## 8.5.2 Guidelines for requesting support

If you cannot resolve a problem using this guide, you can request support from your Honeywell Solution Support Center.

When requesting support, please supply as many relevant details as possible, including:

- **Short summary of the problem**
- **Product Name and release.**
- **Recent changes**, such as upgrades/service packs, to Experion software, Windows or other applications.
- **Subsystem and its version/build**, if the problem relates to a particular subsystem, such as Station or Quick Builder. If the problem relates to **Display Builder**, please specify whether it is HMIWeb Display Builder (for HMIWeb displays) or Display Builder (for DSP displays).
- **Operating system, variant and service pack**, for example 'Windows 2000 Server, SP5'.
- **Instructions on how to reproduce the problem.** If the problem is reproducible, please supply step-by-step instructions - the more detailed the steps the better.
- **Diagnostic package which contains any relevant logs.**

## CHAPTER

## 9

**ALLEN-BRADLEY INTERFACE REFERENCE**

- [Array Channel Block Configuration for Allen-Bradley Interface](#)

## 9.1 Array Channel Block Configuration for Allen-Bradley Interface

The Serial Interface Array Channel function blocks communicate with Allen-Bradley Programmable Logic Controllers (PLC) through the Serial Interface I/O Module (SIM).

The SIM communicates with the Allen-Bradley (A-B) FTA. The A-B FTA communicates with the Allen-Bradley KE/KF Computer Interface Module (CIM) using EIA-232-D protocol at 19,200 baud with even parity. The KE/KF module communicates with PLCs on an Allen-Bradley Data Highway or Data Highway Plus using DF1 protocol with embedded responses. Direct connection to the PLC-5 RS-232 port is also supported. Refer to Allen-Bradley Data Highway protocol manuals for details.

The Allen-Bradley PLC families supported are PLC-2, PLC-3, and PLC-5. The PLC-5 family consists of the 5/10, 5/15, 5/25, 5/40, and 5/60 models.

- [AUXDATA parameter configuration for Allen-Bradley interface](#)
- [AUXDATA\[6\] parameter setting details](#)
- [DEVADDR parameter configuration](#)
- [STARTINDEX and number of elements parameters configuration](#)
- [Report by Exception requirements](#)
- [Performance considerations when Array Channel Block is configured for Allen-Bradley Interface](#)
- [Array Channel block execution state when Array Channel Block is configured for Allen-Bradley Interface](#)
- [Write processing considerations when Array Channel Block is configured for Allen-Bradley Interface](#)
- [Diagnostic procedures and data configuration](#)
- [Time-Out gate configuration](#)
- [Status and error checking when Array Channel Block is configured for Allen-Bradley Interface](#)
- [Error messages when Array Channel Block is configured for Allen-Bradley Interface](#)
- [Special FTA to KE/KF cabling considerations](#)
- [FTA direct to PLC-5 RS-232 Port cable considerations](#)
- [Reference Specifications when Array Channel Block is configured for Allen-Bradley Interface](#)

### 9.1.1 AUXDATA parameter configuration for Allen-Bradley interface

The following table summarizes the AUXDATA parameter configuration that defines Serial Interface Array Channel block communications with the Allen-Bradley PLC.

## Chapter 9 - Allen-Bradley Interface Reference

**ATTENTION**

When the AUXDATA[0..7] parameters are not being used with an Allen-Bradley interface, they should be set to the default value of NaN (Not a Number).

Parameter	Function	Description
AUXDATA [0] to AUXDATA [3]	These parameters are not applicable to an Allen-Bradley interface.	Set these parameters to NaN when communicating with an Allen-Bradley PLC.
AUXDATA [4]	Specifies the Allen-Bradley PLC family type.	<p>Use the following setting for a given PLC type.</p> <ul style="list-style-type: none"> <li>• 2.0 for PLC-2 type</li> <li>• 3.0 for PLC-3 type</li> <li>• 5.0 for PLC-5 type</li> </ul> <p>You can access different PLC family types through the same FTA by using multiple Serial Interface Array Channel blocks with the desired family type setting specified for each Array Channel block's AUXDATA[4] parameter. You can access PLC-3 or PLC-5 type controllers using PLC-2 emulation by setting the AUXDATA[4] parameter value to 2.0.</p> <p>For diagnostic related Array Channel blocks, you must set the AUXDATA[4] parameter to '0' for a Computer Interface Module or 'NaN' for a loopback test. See the following section <i>Diagnostic data configuration</i> for details.</p>
AUXDATA [5]	Specifies the Allen-Bradley PLC file number.	<p>Use the following setting for a given PLC type.</p> <ul style="list-style-type: none"> <li>• NaN for PLC-2 type</li> <li>• 0 to 999 for PLC-3 or PLC-5 type</li> </ul> <p>For diagnostic related Array Channel blocks, you must set the AUXDATA[5] parameter to '-1' for a Computer Interface Module or PLC type, or '-3' for a loopback test. See the following section <i>Diagnostic data configuration</i> for details.</p>
AUXDATA [6]	Specifies the data type for Allen-Bradley PLC -2 or PLC-5 type or the section ID for a PLC-3 type.	<p>See the paragraph following this table for details about making AUXDATA[6] settings for a given PLC type.</p> <p>Different settings are required for diagnostic related Array Channel blocks. See the following section <i>Diagnostic data configuration</i> for details.</p>
AUXDATA [7]	Specifies the Allen-Bradley PLC scan rate.	<p>Each Array Channel block can have a different scan rate. The Allen-Bradley interface supports either polling or Report by Exception (RBE) independent of the scan rate. Use the following setting for a given scan rate.</p> <ul style="list-style-type: none"> <li>• 0 to scan the channel as fast as possible</li> <li>• 1 to 255 to scan the channel once every 1 to 255 seconds</li> <li>• 256 to scan the channel once after configuration or after link or device failure recovery (then only Report by Exception)</li> </ul> <p>Notes:</p> <ol style="list-style-type: none"> <li>1. Use higher priority scanning for time-critical data, and slower scanning or RBE for lower priority channels where data changes infrequently.</li> </ol>

Parameter Function	Description
	<ol style="list-style-type: none"> <li>2. If all channels are set for very fast scan (0 to 2 seconds), actual performance may be less than one update per second, especially when writes are used.</li> <li>3. A setting greater than 256 causes a POL_FREQ error.</li> <li>4. If more than one Array Channel block is configured to map the same PLC memory area, only one of the blocks will be updated with RBE data.</li> <li>5. After the first scan is completed with a setting of 256, Array data is updated when RBE data is received for that channel or after any communication error (but not after configuration errors).</li> <li>6. The RBE feature is independent of the scan rate. See the section Report by Exception requirements for details.</li> </ol>

### 9.1.2 AUXDATA[6] parameter setting details

The following tables list the AUXDATA[6] parameter settings required for a given data type and A-B PLC type. It also lists the Array Channel block associated with a given data type as well as the data range and maximum number of elements.

**WARNING**

An unexpected write may take place when changing AuxData[6] (data type) online, in the following scenario:

1. Data Type was 4 or 5 (read only unsigned).
2. An online value change was attempted. The change is ignored.
3. Data Type is changed to other writable numeric type.

The previously-attempted change is now accepted and passed to the PLC.

- PLC-2 type settings:

Data Type	AUXDATA[6] Setting	Array Channel Function Block	Data Range	Max. No. Elem.
Output	0	SIFLAGARRCH	ON/OFF	512
Input	1	SIFLAGARRCH	ON/OFF	512
Status	2	SIFLAGARRCH	ON/OFF	512
Bit	3	SIFLAGARRCH	ON/OFF	512
Integer	4,5	SINUMARRCH (unsigned 16 Bit)	0 to 65535	32
Floating Point	6	Unsupported (VAX F Format)	-	-
Integer	7	SINUMARRCH (signed 16 Bit)	-32768 to 32767	32
Floating Point	8	SINUMARRCH (IEEE Single Precision)	-34E38 to 34E38	16
ASCII	9	SITEXTARRCH	Printable Characters	8 of 8 4 of 16

Chapter 9 - Allen-Bradley Interface Reference

Data Type	AUXDATA[6] Setting	Array Channel Function Block	Data Range	Max. No. Elem.
				2 of 32 1 of 64
Note: The PLC-2 controller only recognizes status or integer data types. The interface handles other data types by requesting single or multiple elements for integer data according to the AUXDATA[6] setting. The SIM does not support the VAX F format.				

- PLC-3 type settings:

Data Type	AUXDATA[6] Setting	Array Channel Function Block	Data Range	Max. No. Elem.
Output	1	SIFLAGARRCH	ON/OFF	512
Input	2	SIFLAGARRCH	ON/OFF	512
Integer	5	SINUMARRCH (signed 16 Bit)	-32768 to 32767	32
Floating Point	6	Unsupported (VAX F Single Precision)	-	-
Binary	8	SIFLAGARRCH	ON/OFF	512
ASCII	9	SITEXTARRCH	Printable Characters	8 of 8 4 of 16 2 of 32 1 of 64
Status	13	SIFLAGARRCH	ON/OFF	512
Notes: <ol style="list-style-type: none"> <li>1. The setting for AUXDATA[6] corresponds to the PLC-3 controller Section Identifier.</li> <li>2. The PLC-3 controller does not support these data types: timers, counters, decimal, high order (two word) integers, and pointers.</li> <li>3. The SIM does not support the VAX F format.</li> </ol>				

- PLC-5 type settings:

Data Type	AUXDATA[6] Setting	Array Channel Function Block	Data Range	Max. No. Elem.
Output	0	SIFLAGARRCH	ON/OFF	512
Input	1	SIFLAGARRCH	ON/OFF	512
Status	2	SIFLAGARRCH	ON/OFF	512
Bit	3	SIFLAGARRCH	ON/OFF	512
Integer	*4,5	SINUMARRCH (unsigned 16 Bit)	0 to 65535	32
Integer	7	SINUMARRCH (signed 16 Bit)	-32768 to 32767	32
Floating Point	8	SINUMARRCH (IEEE Single Precision)	-34E38 to 34E38	16
ASCII	9	SITEXTARRCH	Printable Characters	8 of 8 4 of 16

Data Type	AUXDATA[6] Setting	Array Channel Function Block	Data Range	Max. No. Elem.
				2 of 32
				1 of 64
<p>*These Allen-Bradley file types are read only and writes to them are ignored.</p> <p>Notes:</p> <ol style="list-style-type: none"> <li>The setting for AUXDATA[6] corresponds to the PLC-5 controller file type, except 9 is assigned for string data. Configure the PLC-5 file to use data type 'A' (ASCII), not data type 'ST' (string).</li> <li>Timers/counters require three words per timer/counter. Presets and accumulated values are read only. They can only be modified in ladder logic.</li> <li>The following restrictions also apply for PLC-5: <ul style="list-style-type: none"> <li>If the AUXDATA[5] setting is 0, then AUXDATA[6] must be set to 0 (output data).</li> <li>If the AUXDATA[5] setting is 1, then AUXDATA[6] must be set to 1 (input data).</li> <li>If the AUXDATA[5] setting is 2, then AUXDATA[6] must be set to 2 (status).</li> </ul> </li> </ol>				

### 9.1.3 DEVADDR parameter configuration

You configure the device address (DEVADDR) parameter to specify the Node Address for the A-B PLC in octal. For example, if the PLC Node Address is 75<sub>8</sub>, enter 75 as the device address setting in the Array Channel block configuration form. More than one Array Channel block can have the same device address.

The valid Node Address range is 0<sub>8</sub> to 376<sub>8</sub>. (Note that the FTA firmware does the octal to decimal conversion automatically, so do **not** convert the octal address to decimal.)

### 9.1.4 STARTINDEX and number of elements parameters configuration

The value configured for the STARTINDEX parameter in a given Array Channel block determines the PLC data table location and function. Only one type of external data (Flag, Numeric, or String) can be accessed per Array Channel block. The following paragraphs describe the setting considerations for a given PLC type.

- PLC-2 Type:** Use the appropriate octal address within the PLC-2 data table. For example, if the octal address is 176<sub>8</sub>, enter 176 as the start index setting in the Array Channel block configuration form.
- PLC-3 Type:** Use either the word part of the PLC-3 address or the structure value for the floating point data. For all data types except input/output (I/O), the decimal range is 0 to 9999<sub>10</sub>. For I/O data, enter the start index setting in the Array Channel block configuration form as an octal number. The range for actual I/O is 0<sub>8</sub> to 377<sub>8</sub> and the range for storage locations is 400<sub>8</sub> to 777<sub>8</sub>.

The PLC-3 Context and External Data Tables are only supported to the extent that Context is fixed equals 1 (current context) and the External Data Table is always equal to E3.

- PLC-5 Type:** Use the file start index depending on the type of data (Flag, Numeric, String).

For flag data, the start index setting represents the word address within the file. If the AUXDATA [6] setting is 0 (Output) or 1 (Input), enter the start index for a Flag Array Channel block as an octal number in the range of 000<sub>8</sub> to 177<sub>8</sub>. A non-octal digit or an out-of-range value causes a STARTIDX error.

Specify all other start index settings as integers, including flag array data except as noted above for input or output data type. The SIM does not check file size.

Chapter 9 - Allen-Bradley Interface Reference

The number of elements parameter (NFLAG, NNUMERIC, or NSTRING) in a Flag Array, Numeric Array, or Text Array Channel block determines the number of flags, numerics, or strings in a given data array. The tables in *AUXDATA[6] parameter setting details* section list the maximum number of elements for a given data type for reference.

### 9.1.5 Report by Exception requirements

Before an FTA will accept RBE data, the following conditions must be true.

- The corresponding Array Channel block must be configured.
- The channel must have been scanned at least once.
- The sending device's source address (SRC) must match the Array Channel block's configured device address (DEVADDR) parameter.
- The quantity of the data received by the FTA in an RBE request must match the quantity of the data configured for the destination Array Channel block.
- The command code (CMD) and the function number (FNC) in the Allen-Bradley communication messages must be as specified in the following table.
- An RBE\_FULL error results if even one RBE message is rejected without indication back to the device that generated the message.
- RBE data is rejected by any Array Channel block configured to map diagnostic counter data, or run a diagnostic loop, or by any PLC-5 configured for Timer/Counter data.
- For a PLC-5 controller, the Data Type (AUXDATA[6]) parameter must match the file type start index configured for the destination Array Channel block.

Note that configuring more than one Array Channel block to map the same PLC memory area results in only one of the Array Channel blocks being updated with RBE data.

Function	PLC-2	PLC-3	PLC-5
Data Read by SIM from PLC (All Data Types)	Basic Command Set: 'Unprotected Read' CMD: 01 FNC: N/A	Specific command 'Word Range Read' CMD:0F FNC: 01	Specific command 'Word Range Read' CMD:0F FNC: 01
Data Write by SIM to PLC (Flag Data Type)	Basic Command Set: 'Unprotected Bit Write' CMD: 05 FNC: N/A	Specific command 'Bit Write' CMD:0F FNC: 02	Specific command 'Read-Modify-Write' CMD:0F FNC: 26
Data Write by SIM to PLC (Other Data Types)	Basic Command Set: 'Unprotected Write' CMD: 08 FNC: N/A	Specific command 'Word Range Write' CMD:0F FNC: 00	Specific command 'Word Range Write' CMD:0F FNC: 00
Data Write by PLC to SIM (RBE) (All Data Types)	Basic Command Set: 'Unprotected Write' CMD: 08 FNC: N/A	Specific command 'Word Range Write' CMD:0F FNC: 00	Specific command 'Typed Write' CMD:0F FNC: 67
*These functions must use the Logical Binary Addressing format or the RBE message is rejected by the SIM. Other formats including PLC-3 Symbolic and PLC-5 Logical ASCII will be rejected.			

### 9.1.6 Performance considerations when Array Channel Block is configured for Allen-Bradley Interface

**ATTENTION**

- Since the Serial Interface I/O Module (SIM) bandwidth is limited, the Array Channel blocks only process writes which change the current process value. This eliminates unnecessary repeated writes.
- In Experion systems with redundant Controller configurations, the writes are not guaranteed during a failover. The store attempt may occur in the Primary Controller, but it may not reach the SIM before the failover occurs. The Secondary Controller does not attempt to resend the data.

An active SIM function block processes the following actions once per its publication period of 250 milliseconds. The publication rate is the same whether the SIM block is assigned to a 5ms-CEE or a 50ms-CEE type.

- Load Serial Interface Array Channel block configurations to the SIM.
- Send Array Channel block write requests to the SIM.
- Monitor status of the SIM, and report diagnostics, as applicable.

Of course, these actions are not performed when the SIM block is inactive. When the SIM block is inactive, the Array Channel blocks set their data to applicable default values.

The SIM block collects the writes for each array channel and sends them to the SIM every 250ms. The following table lists the maximum number writes a SIM block supports per channel in every 250ms cycle. If the SIM block's write list becomes full, it rejects a write to the array channel block.

Array Channel Block	Maximum Number of Writes (Channel/250ms)
SINUMARRCH	8
SIFLAGARRCH	16
SITEXTARRCH (STRLEN = 8)	8
SITEXTARRCH (STRLEN = 16)	4
SITEXTARRCH (STRLEN = 32)	2
SITEXTARRCH (STRLEN = 64)	1

Writes to Array Channel Blocks can also be rejected because the SIM is not keeping up with the writes being sent by the SIM block. Write overruns are indicated by the SIM block FTAAOVRNFL and FTABOVRNFL parameters. To provide an overrun condition alarm, connect the overrun parameters to a FLAG function block configured to generate an OffNormal alarm.

For an Allen-Bradley interface, all configured Array Channel blocks scan the PLC devices in a circular sequence at the specified scan rate with the read data requests. A write data request preempts the read requests (and/or response to any RBE requests). The number of consecutive write data requests is limited to eight (8), after which a Report by Exception request or scan read request is serviced. If outputs, RBE requests, and scan read requests are stacked continuously, the RBE requests and scan read requests are alternately serviced after every eight outputs. This slows data acquisition considerably.

Channels with a scan frequency of 3 to 255 seconds are scanned once upon block activation and then at the configured scan rate. RBE messages reset the scan interval timer, therefore frequent RBE messages can prevent unnecessary scanning.

There is a limit to the number of write requests per second that can be serviced before read response is significantly affected. Because of the time ladder logic takes to execute the maximum number of write requests per second to a PLC running ladder logic should be limited even further. Your Honeywell representative can provide test data and reports on PLC modules certified to date.

### 9.1.7 Array Channel block execution state when Array Channel Block is configured for Allen-Bradley Interface

The Array Channel block uses the Execution State (EXECSTATE) and Execution Period (PERIOD) parameter settings for the Control Module that contains it. When the Control Module is activated,

Chapter 9 - Allen-Bradley Interface Reference

the Array Channel block sends its configuration to the SIM function block for loading in the SIM/FTA. Inactivating and activating the Control Module/Array Channel block, reloads the configuration.

**CAUTION**

It may take a few seconds after the Array Channel block is activated for the configuration to be loaded to the SIM/FTA and good data to be imaged from the device to the Array Channel block. During this time, short duration BADPV alarms may occur on blocks that are accessing the channel's array data.

The following actions are taken to prevent delay in communications to Array Channel blocks that are active and communicating without error due to an *inactive* Array Channel block with communication errors, requests, retries, or timeouts to a bad or out-of-service device in the FTA.

Execution State Action	Additional Reference Information
When the CEE state is set to IDLE or when the EXECSTATE of the Array Channel block is set to <i>inactive</i> , the Array Channel block clears/disables SIM/FTA communications.	When the CEE state is set to IDLE or when the EXECSTATE of the Array Channel block is set to <i>inactive</i> , the CEE sends a NULL array database for the associated Array Channel block to the SIM and FTA to stop the associated communication requests. However, all the Controller to SIM connections will be maintained.
When the CEE state transitions from IDLE to RUN and when the Array Channel block is <i>active</i> , the channel block initializes/enables SIM/FTA communications.	When the CEE is set to IDLE or all Array Channel blocks to a device are set <i>inactive</i> , the FTA foreign device communications stops. Once all the Control Module Array Channel blocks communicating to a particular failed device are set to <i>inactive</i> , the communication to that device is stopped by both the SIM and FTA(s). Communication to other error-free device addresses will no longer be delayed for requests, retries, or timeouts to the bad or out-of-service device in the FTA
When the EXECSTATE of the Array channel block transitions from <i>inactive</i> to <i>active</i> and if the CEE is in RUN, the Array Channel block initializes/enables SIM/FTA communications.	When the EXECSTATE of at least one Control Module Array Channel block configured for a particular device is set <i>active</i> , the configuration will be downloaded to the FTA and the communication gets established again, if the device is healthy.

### 9.1.8 Write processing considerations when Array Channel Block is configured for Allen-Bradley Interface

The Array Channel block array data can be written to either through a one-time store from a Sequential Control Module, an operator, or continually through a wired connection.

Upon receiving a store request, the Array Channel block forwards the requested store to the SIM block. The SIM block forwards the store request to the SIM and FTA. The stored value is not saved in the Array Channel block. The Array Channel block value does not change until the imaged value shows the new value, indicating that the store really made it to the end device.

**ATTENTION**

We recommend using a read-back check to verify that a write is successful in reaching the external device. A read-back check reads the parameter just written and compares it to the value written. When the compared values are equal, it guarantees that the write was successful all the way to the serial device. The feedback time varies based on SIM, FTA, and device performance.

## 9.1.9 Diagnostic procedures and data configuration

Diagnostic data is stored as single or double bytes of information in the Allen-Bradley Highway module. The various PLC modules hold diagnostic information in different forms and in different RAM locations. This data is referred to as the Diagnostic Counters.

The Allen-Bradley diagnostic commands supported by the procedures that follow are:

Diagnostic Status

Diagnostic Read

Diagnostic Counters Reset

Only modules whose diagnostic information address is returned as a reply to a Diagnostic Status Command in the seventh and eighth bytes are supported (PLC-5 returns 0). This address is added to the value specified in the STARTINDEX as an offset, and a Diagnostic Read collects data into the SIM. Therefore, you do not need to know the starting address for diagnostic data.

Because of differences between modules, you must be familiar with the equipment to properly configure an Array Channel block for diagnostic purposes. It is also up to you to interpret the diagnostic data returned. The software automatically reformats data from diagnostic counters for easier interpretation.

You can cause a Diagnostic Counters Reset by executing a write to any element of the diagnostic array counters. Note that a write to any one diagnostic counter resets all the diagnostic counters in the module.

Use the settings in the following table to configure a Numeric Array Channel block to acquire diagnostic information from an Allen-Bradley KE/KF Computer Interface Module (CIM). Numeric data is used for diagnostic counters.

Parameter	Setting for Diagnostic Data
DEVADDR	The node address (specified in octal)
AUXDATA[4]	0 (indicates CIM)
AUXDATA[5]	-1 (indicates diagnostic counter)
AUXDATA[6]	11 for up to 32 values of 2-byte data 7 for up to 32 values of 2-byte data 20 for up to 64 values of single-byte data
AUXDATA[7]	Scan frequency
STARTINDEX	Offset into Allen-Bradley Diagnostic Table*
NNUMERIC	Number of diagnostic words/bytes
* You must know which CIM is used because each model can have different meanings for its offset values.	

Use the settings in the following table to configure a Numeric Array Channel block to acquire diagnostic information from an Allen-Bradley PLC. Numeric data is used for diagnostic counters.

Parameter	Setting for Diagnostic Data
DEVADDR	The node address (specified in octal)
AUXDATA[4]	2, 3, or 5 (indicates PLC type)
AUXDATA[5]	-1 (indicates diagnostic counter)
AUXDATA[6]	11 for up to 32 values of 2-byte data 7 for up to 32 values of 2-byte data 20 for up to 64 values of single-byte data
AUXDATA[7]	Scan frequency
STARTINDEX	Offset into Allen-Bradley Diagnostic Table*
NNUMERIC	Number of diagnostic words/bytes

## Chapter 9 - Allen-Bradley Interface Reference

Parameter	Setting for Diagnostic Data
* You must know which PLC model is used because each model can have different meanings for its offset values.	

Use the settings in the following table to configure a Text Array Channel block to set up a diagnostic loop. A repetitive diagnostic loop can be set up to check the integrity of transmissions over the communications link. It works by transmitting a message of a certain length from the FTA which causes the A-B device to reply by transmitting the same data back to the FTA. String data is used for this purpose.

Parameter	Setting for Diagnostic Data
DEVADDR	The node address (specified in octal)
AUXDATA[4]	NaN
AUXDATA[5]	-3
AUXDATA[6]	NaN
AUXDATA[7]	Scan frequency (but <b>not</b> 256)
STARTINDEX	1
STRLEN	64 characters
NSTRING	1

Counters check the attempted/successful transactions and when the block is active, monitor data block.str[1] should contain the message:

Loopback Test: Attempted - xxxxx Pass - xxxxx

Where xxxxx is a pass/failure count.

Any communication errors are displayed, but the BADPVFL is not set for a diagnostic loop.

Note that the loopback test can run along with other Array Channel block scans, but doing so adversely affects performance.

### 9.1.10 Time-Out gate configuration

The time-out gate feature checks for communication between the FTA and the Allen-Bradley device. This lets the PLC know that the Serial Interface is working.

By configuring an Array Channel block for a periodic write (such as every 10, 20 or 30 seconds), the PLC issues a Report by Exception message. This causes the FTA to return a status message that the ladder logic can monitor and react to.

If the FTA fails, the PLC receives a status code  $20_{16}$  and/or a timeout occurs indicating to the PLC that the host is not communicating. When the FTA recovers, the condition clears and the normal 00 status (message was successful) returns.

### 9.1.11 Status and error checking when Array Channel Block is configured for Allen-Bradley Interface

Several Array Channel block and SIM block parameters provide status reporting. Error information appears in the form of a detailed code or status flag. If configured, Error information appears on the Array Channel block in the Monitoring tab in Control Builder (CB) or the Channel and SIM block detail displays. You should periodically check these block parameters.

**BADPVFL/ERRFL:** Provides overall status of array data (ON = bad). The overall status is bad when there are communication problems or the SIM block is inactive.

**INITREQ:** Tied to ERRFL status. It always equals the status of the ERRFL. This parameter is provided for the sake of consistency with other function blocks to indicate if the block can be stored to at the current time.

**ERRCODE:** When ERRFL is ON, provides a detailed 8-character string. Refer to the following Error Messages section for more information.

## 9.1.12 Error messages when Array Channel Block is configured for Allen-Bradley Interface

The following table lists some possible Serial Interface and Allen-Bradley communication errors for reference. You may also need to refer to the Allen-Bradley documentation for error messages specific to the PLC.

ERRCODE String	Description
<b>Serial Interface Error Codes</b>	
# ELEMNT	Number of elements is out of range for the given Array Channel block.
ARR INIT	Array Channel block is configured, but no valid data has been received.
AUXMATCH	AUXDATA[2] and AUXDATA[3] configuration settings do not match the other channels in the FTA. All channels must agree.
BAUD/PAR	The Baud Rate/Parity setting in AUXDATA[3] is not a valid setting.
CEE Idle	The CEE is Idle, so the function blocks are executing.
CFG_WAIT	The SIM is waiting for valid communications from the FTA before attempting to send the slot configuration.
CFG LOAD	SIM is loading configuration to FTA.
ChCfgErr	Array Channel block configuration error exists. Check block configuration carefully.
Ch Inctv	Control Module containing the Array Channel block is inactive.
CONFIG	Can not load configuration to the SIM. Check all configuration data carefully.
DataCond	Array Channel block does not understand Data Conditioner (internal value) sent by the FTA.
DataType	Array Channel block is not supported or out of range for this device.
DEV ADDR	Configured device address is out of range.
Fac Test	A factory test diagnostic is in progress.
FTA COMM	SIM can not communicate with the FTA.
Inv Resp	An invalid field device response has occurred.
IO Comm	There is an I/O communications problem between the CPM and the SIM.
KPA ADDR	Keep Alive coil address in out of range.
MAX CONF	"Catch All" configuration error.
Md Inctv	The SIM function block is inactive, so the Array Channel block can not get new array data.
NO CONF	No configuration (Channel is not viewable at the operator Station).
No Conn	The Array Channel block can not get data because a proper connection does not exist between the CPM and the SIM.
No Data	Transient condition that occurs when the Control Module containing the Array Channel block is activated. Condition clears once ERRFL is set OFF or ON.
No SIMFB	Array Channel block can not locate its assigned SIM block. Be sure the SIM block is loaded to the CEE.
PLC TYPE	PLC type is not supported.
POL FREQ	Polling frequency is out of range.
SIG/MOD	AUXDATA[2] setting is not valid.
Startidx	The STARTINDEX address is out of range.
STR LEN	Illegal string length for diagnostic loop channel type.
TMOT VAL	Message timeout value is out of range.
<b>Allen-Bradley Communication Error Codes</b>	
ABEXT_mm	Allen-Bradley remote station specific EXT STS error (refer to Allen-Bradley documentation).
ABSTS_nn	Allen-Bradley local/remote station specific STS error (refer to Allen-Bradley

Chapter 9 - Allen-Bradley Interface Reference

ERRCODE String	Description
	documentation)
ACKTMOUT	Timed out waiting for ACK from CIM device.
ARR INIT	Point configured, but no valid data received yet.
CHECKSUM	Incorrect BCC detected on the last received message.
CIM_NAK	Received a NAK from the CIM device.
INV RESP	Invalid response received from the Allen-Bradley device.
MAXMSGST	"Catch all" Serial Interface error.
MSGTMOUT	Timed out waiting for the Allen-Bradley device to reply to the last request.
OK_POLL	No errors exist against the Array Channel block whose poll rate is within 0 to 255.
OK_RBE	No errors exist against the Array Channel block whose poll rate is 256.
PARITY	Incorrect parity on at least one character in the last received message.
RBE_FULL	RBE buffer full due to too many Report by Exception requests from the PLC devices.

### 9.1.13 Special FTA to KE/KF cabling considerations

As previously mentioned, an Allen-Bradley KE/KF Computer Interface Module (CIM) is usually used to communicate with an A-B FTA. The recommended KE/KF CIM configuration is full duplex, even parity, BCC, embedded response disabled, 19,200 baud, and diagnostic pass-through. A special cable with 25-pin (male) to 15-pin (male) connectors and wired as shown below is required to connect the KE/KF CIM to the A-B FTA.

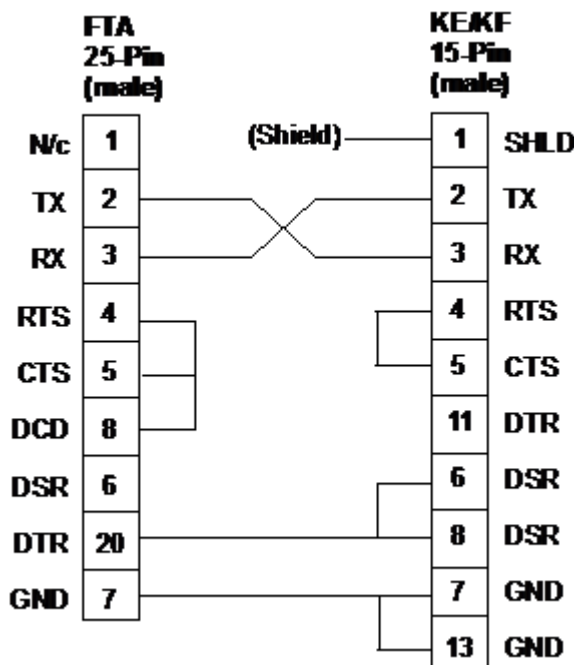

### 9.1.14 FTA direct to PLC-5 RS-232 Port cable considerations

To make a direct connection between the FTA and a PLC-5, you must configure the PLC-5 serial port as RS-232, full duplex, even parity, 19,200 baud, and diagnostic pass through, ignore duplicate messages. Do **not** configure the port as RS-422 or RS-485. You will need a null modem cable with 25-pin male connections to connect the PLC-5 to the A-B FTA. The cable connections are shown below for reference.

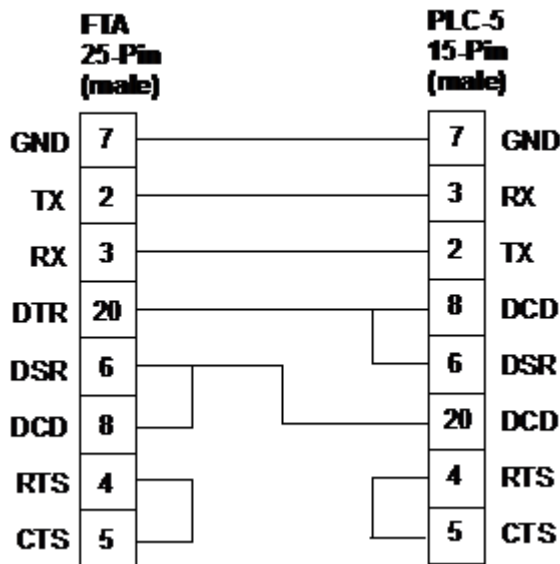

### 9.1.15 Reference Specifications when Array Channel Block is configured for Allen-Bradley Interface

The following table lists some general specifications relevant to the Serial Interface function.

Function	Description
<b>Serial Interface Array Channel</b>	
FTA Channel Capacity	Up to 16 channels per SI FTA
SIM Channel Capacity	Up to 32 channels per SIM (2 FTAs)
Data capacity per Array Channel (contiguous data in PLC)	512 Flags (Boolean/coils), or 64 Numerics (8-Bit integers), or 32 Numerics (integers), or 16 Numerics (reals), or 1 string of 64 characters, or 2 string of 32 characters, or 4 string of 16 characters, or 8 string of 8 characters
Reads per Port *	Up to 2048 Booleans/second, or Up to 128 integers/second, or Up to 64 reals/second, or Up to 4, 64-character strings/second, or Weighted combinations of the above
Writes per Port*	10 channels/second
* Read and write performance is sensitive to a number of variables, including the PLC type, scan time, PLC network configuration and traffic, amount of data access from other devices, and the overall health of the PLC network. For best results, a direct PLC connection is recommended. The ratings listed do <b>not</b> represent best performance figures. Read performance degrades with increased writes.	
<b>Allen-Bradley Serial Interface</b>	
<i>Model Numbers</i>	
A-B SI FTA	MU-TSIA12

## Chapter 9 - Allen-Bradley Interface Reference

Function	Description
SIM	TC-MUX021
SIM FTA Power Adapter	TC-SMPD01 (24 Vdc, 18-36 Vdc, 0.4A maximum) TC-SMPC01 (85 to 265 Vac, 47-63 Hz, 12W maximum)
<i>General</i>	
Interface Type	EIA-RS232-D
Number of Serial Ports	2 per SIM, 1 per FTA
Power Adapter to FTA Distance	300 meters (984 feet)
Baud Rate	19,200 baud
Serial Data Format	8 data Bits with even parity
Common Mode Operation	250 Vrms (continuous)
ESD Protection	IEEE SWC 472-1974
<i>EIA-RS232-D Support</i>	
Interface Type	Serial asynchronous
Lines Supported	TXD, RXD, Logic GND, Protectiv GND (Compatible with CCIT V.24; CCIT V.28)
FTA to Device Distance	15 meters (49 feet)
<i>Allen-Bradley Specific</i>	
Protocol	Full duplex Allen-Bradley DF1 with embedded responses
Transmission Mode	Character oriented
Serial Line Mode	RS232
Parity	Even
Number of Stop Bits	1
Modem Control Support	Off
ACK Timeout	3.2 seconds
FTA Message Response Timeout	4.0 seconds
Data Format Supported	Booleans, Reals, Signed/Unsigned Integers, ASCII Strings
CIM Communications Options	Pass-through diagnostic requests Ignore handshaking Accept duplicate message BCC error check
PLC Types Supported	PLC-2 PLC-3 (Native Mode and PLC-2 Mode) PLC-5, except PLC-5/20 (Native Mode and PLC-2 Mode)

CHAPTER

10

**MODBUS INTERFACE REFERENCE**

- [Array Channel Block Configuration for Generic MODBUS Interface](#)
- [Extended range versus limited range Modbus FTA](#)
- [Starting element index value differences](#)

**10.1 Array Channel Block Configuration for Generic MODBUS Interface**

Many devices that use the AEG Modicon Modbus RTU protocol can communicate with the Experion system through the Array Channel blocks for the SIM. Refer to Modbus documentation for a description of the Modbus protocol.

- [AUXDATA parameter configuration](#)

**10.1.1 AUXDATA parameter configuration**

The following table summarizes the AUXDATA parameter configuration that defines Serial Interface Array Channel block communications with the Generic Modbus. It also defines the optional entries for parameters to request the extended range addressing of the Modbus interface STARTINDEX through the Control Builder application as well as the additional parameters included to control the retries of Modbus device communications.

**ATTENTION**

- When the AUXDATA[0...7] parameters are not being used with a Generic Modbus interface, they should be set to the default value of NaN (Not a Number).
- If the chip revision level of you Modbus SI FTA is **H** or above, you can configure AUXDATA[4] to increase the delay between messages sent to the Modbus device.

**TIP**

Use the NetworkTools (NTools) utility to check the revision level of the installed Modbus SI FTA through the detail pane display for the SIM. See the 'Tools and Utilities' section in the C200 Hardware Troubleshooting and Maintenance Guide for more information.

Parameter	Function	Description
AUXDATA [0]	Specifies the Keep Alive Address for a Modbus coil.	This parameter tells the Modbus system that the Experion subsystem is functioning. It can be configured separately on each array channel block, but no two array channel blocks should write to the same coil. The coil address must be within the range 00001 to 09999 for limited range FTA or 000001 to 099999 for extended range FTA.

Chapter 10 - MODBUS Interface Reference

Parameter Function		Description
		Note: When this parameter is NaN, the Keep Alive function is inactive. If you want to check the Keep Alive coil, you must program the Modbus device to do so.
AUXDATA [1]	Specifies the time interval in seconds to wait before attempting a message retry.	If a valid response is not received after three tries (original plus two retries), a MSGTMOUT error results. The range is 0.25 to 5 seconds on NaN. If NaN is specified, the default timeout is 1.5 seconds. A timeout value can be configured separately for each array channel block.
AUXDATA [2]	Specifies the signaling protocol and modem control in an integer/decimal format:  <b>mmm.n</b>  Where <b>mmm</b> is the signaling protocol and <b>n</b> is the modem control (0 = OFF and 1 = ON).  For example, 232.1 indicates EIA-232 with modem control ON. The other choices are 232.0 and 485.0. EIA-232 permits use of an external modem.	The first valid array channel block loaded to the Controller with values in AUXDATA[2] and AUXDATA[3] sets the mode and baud rate for the FTA communications. This means that AUXDATA[2] AUXDATA[3] must contain the same value for all array blocks configured through the same FTA. If array blocks loaded later to that FTA have different AUXDATA[2]/[3] values, an AUXMATCH error results.  The modem control feature switches the following signals: RTS, CTS, DSR, DTR, and DCD. When AUXDATA[2] is NaN, the protocol is EIA-232 and modem control is OFF.
AUXDATA [3]	Specifies the baud rate in an integer/decimal format:  <b>bbbb.n</b>  Where <b>bbbb</b> is the baud rate and <b>n</b> is the parity (0 = None, 1 = Odd, 2 = Even).	The legal baud rates are 19200, 9600, 4800, 2400, and 1200. NaN (dashes) results in a default value of 19200 baud with odd parity.
AUXDATA [4]	When Modbus SI FTA chip revision is <b>G</b> or below:  This parameter is not applicable to a Generic Modbus interface.  When Modbus SI FTA chip revision is <b>H</b> or above:  Lets you increase the delay between messages sent to the Modbus device.	Set this parameter to NaN when communicating with a Modbus.  The range is 0 to 10000 milliseconds (0 to 10 seconds). Default is 0, if AUXDATA[4] = NaN.  It defines the delay in milliseconds between the end of the sub-system reply and the new SI-FTA request (FTA delay), as shown in the following illustration.  This parameter is equivalent to the AB_DATA1 parameter in the APM/HPM Serial Interface.

Parameter Function	Description	
AUXDATA [5]	Lets you enable/disable the extended range addressing for this FTA slot.	<p>To enable extended range addressing, enter 65535.0 for this parameter on the Serial Device tab of I/O Channel block configuration form in Control Builder. To disable extended range addressing, leave the default entry of NaN for this parameter on the configuration form.</p> <p>This parameter is equivalent to the AB_DATA2 parameter on the APM/HPM Serial Interface, but this feature is not valid for APM/HPM. See the previous <a href="#">Converting Limited Range Modbus FTA to Extended Range Modbus FTA</a> section to migrate from limited range addressing to extended range addressing.</p>
AUXDATA [6]	Specifies the number of default retries for the array slot.	<p>Setting range is 0 to 1,000.</p> <p>Using the default entry of NaN leaves the retry value at 2.</p> <p>This parameter is equivalent to the AB_DATA3 parameter on APM/HPM Serial Interface and this feature is valid with APM/HPM.</p>
AUXDATA [7]	Specifies the wait time in seconds before this slot retries the failed communications.	<p>Setting range is 0 to 10,000 seconds.</p> <p>Using the default entry of NaN leaves the value at 0.</p> <p>This parameter is equivalent to the AB_DATA4 parameter on APM/HPM Serial Interface and this feature is valid with APM/HPM.</p>

## 10.2 Extended range versus limited range Modbus FTA

The extended range serial interface FTA can address lower Modbus addresses as well as addresses above 9,999. The Experion R301.1 or later version of Control Builder is compatible with this extended range FTA, since it supports Starting Element Index (STARTINDEX) parameter values up to 99,999. The FTA defines the extended address protocol handling and contains the starting element index mapping, not the SIM.

The existing limited range serial interface FTA supports a maximum address of 9,999 and uses different starting element index values. Otherwise, the FTAs are functionally equivalent.

### TIP

The maximum extended range address of 99,999 more than supports the maximum Modbus address of 65,535. The address range of 65,536 to 99,999 will not be usable by the Modbus standard protocol.

## 10.3 Starting element index value differences

You specify the Starting Element Index (STARTINDEX) parameter through the **Serial Device** tab on

## Chapter 10 - MODBUS Interface Reference

the configuration form for the given serial interface IOCHANNEL block in Control Builder. This parameter defines the Modbus address map.

The value configured for the STARTINDEX parameter in a given Array Channel block determines the Modbus Start Index and function. Only one type of external data can be accessed per Array Channel block.

The STARTINDEX parameter specifies the Modbus data type and a Modbus address up to 9,999 for the limited range FTA or up to 99,999 for the extended range FTA. The most significant digit identifies the Modbus function. For example, read coil status as noted in the following tables. The lower four digits for limited range FTA or five digits for extended range FTA define the starting address to access data for the given Modbus function. For example, the extended range FTA address ranges 2xxxxx, 4xxxxx, 5xxxxx, 7xxxxx, 8xxxxx, and 9xxxxx all address the same xxxxx registers in the programmable logic controller, but with different data formats. The same is true for the limited range FTA xxx registers in the PLC. When multiple numeric data types are used, you must configure the STARTINDEX for each array to avoid overlapping arrays.

The following tables show the relationship between Modbus functions, the STARTINDEX parameter range, and number of elements for a limited range FTA (Table 1) or extended range FTA (Table 2). The maximum number of elements specifies the maximum number of flags (NFLAG), numerics (NUMERIC), or strings (NSTRING) that can be configured for a given STARTINDEX range and IOCHANNEL block type. All of the specified elements are read in a single transaction.

**Table 10.1 Start index ranges for limited range FTA**

Start Index Ranges	Modbus Function	Read FC Write FC	Array Channel Function Block	Data Range	Max. No. Elem.
00001 - 09999	Read Coil Status	01	SIFLAGARRCH	ON/OFF	512
	Force Single Coil	05	Read/Write Bit Flags		
10001 - 19999	Read Input Status	02	SIFLAGARRCH	ON/OFF	512
	Not Applicable	N/A	Read Only Bit Flags		
20001 - 29999 <sup>1</sup>	Read Holding Registers	03	SINUMARRCH	-34E38 to 34E38	16
	Preset Multiple Registers	16 <sup>2</sup>	Word Swapped IEEE Fl.Pt Read/Write		
30001 - 39999	Read Input Registers	04	SINUMARRCH	-32768 to 32767	32
	Not Applicable	N/A	Signed Integer Words Read only		
40001 - 49999	Read Holding Registers	03	SINUMARRCH	-32768 to 32767	32
	Preset Single Register	06	Signed Integer Array Read/Write		
50001 - 59999 <sup>1</sup>	Read Holding Registers	03	SITEXTARRCH	Printable Characters	8 of 8
			ASCII Encoded Bytes Read/Write		4 of 16
					2 of 32
					1 of 64
60000 <sup>1</sup>	Loopback Diagnostics	08	SITEXTARRCH	None	1 of 64
			Loopback Test		
70001 - 79999	Read Holding Registers	03	SINUMARRCH	-34E38 to 34E38	16
	Preset Multiple Registers	16 <sup>2</sup>	IEEE Floating Point Read/Write		
80002 -	Read Holding	03	SINUMARRCH	-34E38 to	16

Chapter 10 - MODBUS Interface Reference

Start Index Ranges	Modbus Function	Read FC Write FC	Array Channel Function Block	Data Range	Max. No. Elem.
89999 <sup>1</sup>	Registers		IEEE Fl. Pt in Addr-1	34E38	
	Preset Multiple Registers	16 <sup>2</sup>	Read/Write		
90001 - 99999	Read Holding Registers	03	SINUMARRCH	0 to 65535	32
	Preset Single Register	06	Unsigned Integer Words Read/Write		

<sup>1</sup>These ranges are extensions to the Modbus protocol specifications to support certain Modbus devices.

<sup>2</sup>Function Code 16 is used to write a multiword data type in one transaction.

Table 10.2 Start index ranges for extended range FTA

STARTINDEX Ranges	Modbus Function	Read FC Write FC	IOCHANNEL Block	Data Range	Maximum Number Elements
000001 - 099999	Read Coil Status	01	SIFLAGARRCH	ON/OFF	512
	Force Single Coil	05	Read/Write Bit Flags		
100001 - 199999	Read Input Status	02	SIFLAGARRCH	ON/OFF	512
	Not Applicable	N/A	Read Only Bit Flags		
200001 - 299999 <sup>1</sup>	Read Holding Registers	03	SINUMARRCH	-34E38 to 34E38	16
	Preset Multiple Registers	16 <sup>2</sup>	Word Swapped IEEE Fl.Pt Read/Write		
300001 - 399999	Read Input Registers	04	SINUMARRCH	-32768 to 32767	32
	Not Applicable	N/A	Signed Integer Words Read only		
400001 - 499999	Read Holding Registers	03	SINUMARRCH	-32768 to 32767	32
	Preset Single Register	06	Signed Integer Array Read/Write		
500001 - 599999 <sup>1</sup>	Read Holding Registers	03	SITEXTARRCH	Printable Characters	8 of 8
			ASCII Encoded Bytes Read/Write		4 of 16
					2 of 32
					1 of 64
	Preset Single Register	06			
600000 <sup>1</sup>	Loopback Diagnostics	08	SITEXTARRCH	None	1 of 64
			Loopback Test		
700001 - 799999	Read Holding Registers	03	SINUMARRCH	-34E38 to 34E38	16
			IEEE Floating Point Read/Write		
	Preset Multiple Registers	16 <sup>2</sup>			
800002 - 899999 <sup>1</sup>	Read Holding Registers	03	SINUMARRCH	-34E38 to 34E38	16
			IEEE Fl. Pt in Addr-1		

Chapter 10 - MODBUS Interface Reference

STARTINDEX Ranges	Modbus Function	Read FC Write FC	IOCHANNEL Block	Data Range	Maximum Number Elements
	Preset Multiple Registers	16 <sup>2</sup>	Read/Write		
900001 - 999999	Read Holding Registers	03	SINUMARRCH	0 to 65535	32
	Preset Single Register	06	Unsigned Integer Words Read/Write		
<sup>1</sup> These ranges are extensions to the Modbus protocol specifications to support certain Modbus devices. <sup>2</sup> Function Code 16 is used to write a multiword data type in one transaction.					

- [Modbus loopback diagnostic](#)
- [Performance considerations when Array Channel Block is configured for Generic MODBUS Interface](#)
- [Array Channel block execution state when Array Channel Block is configured for Generic MODBUS Interface](#)
- [Write processing considerations when Array Channel Block is configured for Generic MODBUS Interface](#)
- [Status and error checking when Array Channel Block is configured for Generic MODBUS Interface](#)
- [Error messages when Array Channel Block is configured for Generic MODBUS Interface](#)
- [Special Modbus slave FTA implementation](#)
- [Reference Specifications when Array Channel Block is configured for Generic MODBUS Interface](#)

### 10.3.1 Modbus loopback diagnostic

The loopback test consists of sending a test message to the Modbus device and waiting for the proper response. To do this, configure a TEXT array channel block as follows. Note that this example is based on using a limited range FTA but it can be easily adapted to an extended range FTA by changing the STARTINDEX to 600000.

- STARTINDEX = 60000 (loopback test address)
- NSTRING = 1
- STRLEN = 64

When the block is active, the monitor data block.str[1] should contain the message:

Loopback Test: Attempted - xxxxx Pass - xxxxx

Where xxxxx is a pass/failure count.

(Note that the loopback test can run along with other Array Channel block scans, but doing so adversely affects performance.)

### 10.3.2 Performance considerations when Array Channel Block is configured for Generic MODBUS Interface

**ATTENTION**

- Since the Serial Interface I/O Module (SIM) bandwidth is limited, the Array Channel blocks only process writes which change the current process value. This eliminates unnecessary repeated writes.
- In Experion systems with redundant Controller configurations, the writes are not guaranteed during a failover. The store attempt may occur in the Primary Controller, but it may not reach the SIM before the failover occurs. The Secondary Controller does not attempt to resend the data.

An active SIM function block processes the following actions once per its publication period of 250 milliseconds. The publication rate is the same whether the SIM block is assigned to a 5ms-CEE or a 50ms-CEE type.

- Load Serial Interface Array Channel block configurations to the SIM.
- Send Array Channel block write requests to the SIM.
- Monitor status of the SIM, and report diagnostics, as applicable.

Of course, these actions are not performed when the SIM block is inactive. When the SIM block is inactive, the Array Channel blocks set their data to applicable default values.

The SIM block collects the writes for each array channel and sends them to the SIM every 250ms. The following table lists the maximum number writes a SIM block supports per channel in every 250ms cycle. If the SIM block's write list becomes full, it rejects a write to the array channel block.

Array Channel Block	Maximum Number of Writes (Channel/250ms)
SINUMARRCH	8
SIFLAGARRCH	16
SITEXTARRCH (STRLEN = 8)	8
SITEXTARRCH (STRLEN = 16)	4
SITEXTARRCH (STRLEN = 32)	2
SITEXTARRCH (STRLEN = 64)	1

Writes to Array Channel Blocks can also be rejected because the SIM is not keeping up with the writes being sent by the SIM block. Write overruns are indicated by the SIM block FTAAOVRNFL and FTABOVRNFL parameters. To provide an overrun condition alarm, connect the overrun parameters to a FLAG function block configured to generate an OffNormal alarm.

### 10.3.3 Array Channel block execution state when Array Channel Block is configured for Generic MODBUS Interface

The Array Channel block uses the Execution State (EXECSTATE) and Execution Period (PERIOD) parameter settings for the Control Module that contains it. When the Control Module is activated, the Array Channel block sends its configuration to the SIM function block for loading in the SIM/FTA. Inactivating and activating the Control Module/Array Channel block, reloads the configuration.

**CAUTION**

It may take a few seconds after the Array Channel block is activated for the configuration to be loaded to the SIM/FTA and good data to be imaged from the device to the Array Channel block. During this time, short duration BADPV alarms may occur on blocks that are accessing the channel's array data.

The following actions are taken to prevent delay in communications to Array Channel blocks that are active and communicating without error due to an *inactive* Array Channel block with communication errors, requests, retries, or timeouts to a bad or out-of-service device in the FTA.

Chapter 10 - MODBUS Interface Reference

Execution State Action	Additional Reference Information
When the CEE state is set to IDLE or when the EXECSTATE of the Array Channel block is set to <i>inactive</i> , the Array Channel block clears/disables SIM/FTA communications.	When the CEE state is set to IDLE or when the EXECSTATE of the Array Channel block is set to <i>inactive</i> , the CEE sends a NULL array database for the associated Array Channel block to the SIM and FTA to stop the associated communication requests. However, all the Controller to SIM connections will be maintained.
When the CEE state transitions from IDLE to RUN and when the Array Channel block is <i>active</i> , the channel block initializes/enables SIM/FTA communications.	When the CEE is set to IDLE or all Array Channel blocks to a device are set <i>inactive</i> , the FTA foreign device communications stops. Once all the Control Module Array Channel blocks communicating to a particular failed device are set to <i>inactive</i> , the communication to that device is stopped by both the SIM and FTA(s). Communication to other error-free device addresses will no longer be delayed for requests, retries, or timeouts to the bad or out-of-service device in the FTA
When the EXECSTATE of the Array channel block transitions from <i>inactive</i> to <i>active</i> and if the CEE is in RUN, the Array Channel block initializes/enables SIM/FTA communications.	When the EXECSTATE of at least one Control Module Array Channel block configured for a particular device is set <i>active</i> , the configuration will be downloaded to the FTA and the communication gets established again, if the device is healthy.

### 10.3.4 Write processing considerations when Array Channel Block is configured for Generic MODBUS Interface

The Array Channel block array data can be written to either through a one-time store from a Sequential Control Module, an operator, or continually through a wired connection.

Upon receiving a store request, the Array Channel block forwards the requested store to the SIM block. The SIM block forwards the store request to the SIM and FTA. The stored value is not saved in the Array Channel block. The Array Channel block value does not change until the imaged value shows the new value, indicating that the store really made it to the end device.

**ATTENTION**

We recommend using a read-back check to verify that a write is successful in reaching the external device. A read-back check reads the parameter just written and compares it to the value written. When the compared values are equal, it guarantees that the write was successful all the way to the serial device. The feedback time varies based on SIM, FTA, and device performance.

### 10.3.5 Status and error checking when Array Channel Block is configured for Generic MODBUS Interface

Several Array Channel block and SIM block parameters provide status reporting. Error information appears in the form of a detailed code or status flag. If configured, Error information appears on the Array Channel block in the Monitoring tab in Control Builder (CB) or the Channel and SIM block detail displays. You should periodically check these block parameters.

**BADPVFL/ERRFL:** Provides overall status of array data (ON = bad). The overall status is bad when there are communication problems or the SIM block is inactive.

**INITREQ:** Tied to ERRFL status. It always equals the status of the ERRFL. This parameter is provided for the sake of consistency with other function blocks to indicate if the block can be stored to at the current time.

**ERRCODE:** When ERRFL is ON, provides a detailed 8-character string. Refer to the following Error Messages section for more information.

## 10.3.6 Error messages when Array Channel Block is configured for Generic MODBUS Interface

The following table lists some possible Serial Interface and Modbus communication errors for reference. You may also need to refer to the Modbus documentation for error messages specific to the serial device.

ERRCODE String	Description
<b>Serial Interface Error Codes</b>	
# ELEMNT	Number of elements is out of range for the given Array Channel block.
ARR INIT	Array Channel block is configured, but no valid data has been received.
AUXMATCH	AUXDATA[2] and AUXDATA[3] configuration settings do not match the other channels in the FTA. All channels must agree.
BAUD/PAR	The Baud Rate/Parity setting in AUXDATA[3] is not a valid setting.
BYPASS	Wait time specified in seconds before slot retries failed communications for AUXDATA[7] parameter exceeds the legal range of 0 to 10,000 seconds.
CEE Idle	The CEE is Idle, so the function blocks are executing.
CFG LOAD	SIM is loading configuration to FTA.
CFG_WAIT	The SIM is waiting for valid communications from the FTA before attempting to send the slot configuration.
ChCfgErr	Array Channel block configuration error exists. Check block configuration carefully.
Ch Inctv	Control Module containing the Array Channel block is inactive.
CONFIG	Can not load configuration to the SIM. Check all configuration data carefully.
DataCond	Array Channel block does not understand Data Conditioner (internal value) sent by the FTA.
DataType	Array Channel block is not supported or out of range for this device. (Most significant digit of STARTINDEX does not match the array channel point. Extended Modbus addressing has a larger address range.)
DELAYVAL	The frame delay setting is out of range (0 to 10000). If AUXDATA[4] is less than 0 or greater than 10000, when Modbus SI FTA chip revision is H or above.
DEV ADDR	Configured device address is out of range.
EXT ADDR	Value for AUXDATA[5] is <b>not</b> NaN or 65535.0. Defines whether extended range addressing is enabled (65535.0) or not (NaN). This defines how the user STARTINDEX parameter is interpreted on this array point slot. FTA slots must have a STARTINDEX value that matches the AUXDATA[5] setting or DATATYPE/STARTIDX errors may occur.
Fac Test	A factory test diagnostic is in progress.
FTA COMM	SIM can not communicate with the FTA.
Inv Resp	An invalid field device response has occurred.
IO Comm	There is an I/O communications problem between the CPM and the SIM.
KPA ADDR	Keep Alive coil address in out of range.
MAX CONF	"Catch All" configuration error.
Md Inctv	The SIM function block is inactive, so the Array Channel block can not get new array data.
NO CONF	No configuration (Channel is not viewable at the operator Station).
No Conn	The Array Channel block can not get data because a proper connection does not exist between the CPM and the SIM.
No Data	Transient condition that occurs when the Control Module containing the Array Channel block is activated. Condition clears once ERRFL is set OFF or ON.
No SIMFB	Array Channel block can not locate its assigned SIM block. Be sure the SIM block is loaded to the CEE.

Chapter 10 - MODBUS Interface Reference

ERRCODE String	Description
PLC TYPE	PLC type is not supported.
POL FREQ	Polling frequency is out of range.
RETRY	The number of default retries specified for slot AUXDATA[6] exceeds the legal range of 0 to 1,000.
SIG/MOD	AUXDATA[2] setting is not valid.
Startidx	The STARTINDEX address is out of range. The address portion has a maximum of 9,999 for limited range addressing or 65,535 for extended range addressing.
STR LEN	Illegal string length for diagnostic loop channel type.
TMOT VAL	Message timeout value is out of range.
<b>Modbus Communication Error Codes</b>	
CHECKSUM	Incorrect checksum received.
Ex or xx	Modbus device error codes (Hex). Refer to device documentation.
NO CTS	Modem did not respond with Clear To Send within the message timeout time.
NO DSR	Modem is not asserting Data Set Ready as expected.
Parity	A Modbus device communication error has occurred.
Checksum	
MSGTMOUT	
ChrTmout	
RX OVFL0	A receive buffer overflow occurred on a message response received from the Modbus device.

### 10.3.7 Special Modbus slave FTA implementation

The following table summarizes the tasks and information associated with implementing a Modbus Slave FTA. The Modbus Slave FTA is available as a repeatable special product (hardware part number 51191029-Tab, documentation part number 51191030).

Task/Information Action/Reference	
<b>Restrictions</b>	<ul style="list-style-type: none"> <li>• Must pair only one Master and one Slave.</li> <li>• Since the Slave responds to all addresses, no other multidrop devices are permitted.</li> <li>• To avoid the Ex-2 error, configure and load the Slave FTA first.</li> <li>• You can configure different device addresses for each Array Channel pair, but only addresses 1 to 15 are legal.</li> </ul>
<b>Configuration</b>	<ul style="list-style-type: none"> <li>• In each Master and Slave Array Channel pair, configure the identical settings for the device address (DEVADDR) and start index (STARTINDEX) parameters.</li> <li>• Configure identical, non-overlapping data areas in Master and Slave Array Channel pairs. For example, if Array 1 is 32 integers with a STARTINDEX of 90001, then Array 2 must have a STARTINDEX of 00033. If Array 1 is 512 Booleans with a STARTINDEX of 00000 and Array 2 is 16 floating points, then Array 2 must have a STARTINDEX of 70513 and Array 3 must have a STARTINDEX of <math>x00001 + 512 + 16 = 529</math>.</li> <li>• In all Slave Array Channels, set AUXDATA[4] parameter to a non-zero value (1.0) to enable the Remote Terminal Unit (RTU) protocol.</li> <li>• In all Master Array Channels, set AUXDATA[1] parameter to recommended 3.0 second timeout.</li> <li>• In all Master and Slave Array Channel pairs, configure the identical settings for AUXDATA[2] and AUXDATA[3] parameters.</li> </ul>

Task/Information Action/Reference	
	<ul style="list-style-type: none"> <li>For short distances, the default is RS-232 direct connection with NaN settings for both AUXDATA[2] and AUXDATA[3] parameters.</li> <li>For long distance, use RS485 connection with a 485.0 setting for the AUXDATA[2] parameter and a 19200.1 setting for the AUXDATA[3] parameter.</li> </ul>
<b>Common Errors</b>	<ul style="list-style-type: none"> <li>If the Master accesses a device address that does not match an existing Slave Array configuration, the Slave responds with an Ex-2 error and freezes. After the Master address is corrected, you must restart or reconfigure the Slave.</li> <li>If the Slave Array is configured with overlapping data areas between arrays, it returns the STRTINDX error code.</li> <li>If the Slave Array is configured with a conflicting device address, it returns the DEV ADDR error code.</li> <li>If the Slave is configured for a STARTINDEX address of 8xxxx, it causes an Ex-2 error code in the Master. The 8xxxx address (IEEE Float at address - 1) is not supported.</li> </ul>

### 10.3.8 Reference Specifications when Array Channel Block is configured for Generic MODBUS Interface

The following table lists some general specifications relevant to the Serial Interface function.

Function	Description
<b>Serial Interface Array Channel</b>	
FTA Channel Capacity	Up to 16 channels per SI FTA
SIM Channel Capacity	Up to 32 channels per SIM (2 FTAs)
Data capacity per Array Channel (contiguous data in PLC)	512 Flags (Boolean/coils), or 64 Numerics (8-Bit integers), or 32 Numerics (integers), or 16 Numerics (reals), or 1 string of 64 characters, or 2 string of 32 characters, or 4 string of 16 characters, or 8 string of 8 characters
Reads per Port *	Up to 2048 Booleans/second, or Up to 128 integers/second, or Up to 64 reals/second, or Up to 4, 64-character strings/second, or Weighted combinations of the above
Writes per Port *	10 channels/second
* Read and write performance is sensitive to a number of variables, including the PLC type, scan time, PLC network configuration and traffic, amount of data access from other devices, and the overall health of the PLC network. For best results, a direct PLC connection is recommended. The ratings listed do <b>not</b> represent best performance figures. Read performance degrades with increased writes.	
<b>MODBUS Serial Interface</b>	
<i>Model Numbers</i>	

Chapter 10 - MODBUS Interface Reference

Function	Description
Limited Range MODBUS SI FTA	MU-TSIM12
Extended Range MODBUS SI FTA	MU-TSIM13 MC-TSIM13
SIM	TC-MUX021
SIM FTA Power Adapter	TC-SMPD01 (24 Vdc, 18-36 Vdc, 0.4A maximum) TC-SMPC01 (85 to 265 Vac, 47-63 Hz, 12W maximum)
<i>General</i>	
Interface Type	EIA-RS232-D or EIA-485
Number of Serial Ports	2 per SIM, 1 per FTA
Power Adapter to FTA Distance	300 meters (984 feet)
Protocol	Modbus
Transmission Mode	RTU
Serial Line Mode	RS232 or RS485
Selectable Baud Rates	1200, 2400, 4800, 9600, 19200 bps
Serial Data Format	8 data bits with programmable ninth bit (parity)
Selectable Parity	None, odd, or even
Common Mode Operation	250 Vrms (continuous)
ESD Protection	IEEE 801.2
Surge Protection	IEEE SWC 472-1974
Number of Stop Bits	1
Modem Control Support	Selectable On/Off
Keep Alive Cell Write	Configurable address
Message Response Timeout Time	Configurable timeout
Inter-Message Stall Time	3.5 Character Time minimum
Data Formats Supported	Boolean, Real, ASCII Strings, Signed Integers, Unsigned Integers
Exception Errors Reported	Keep Alive, Message Response Timeout, Signaling Mode/Modem Support, Baud Rate, Parity
<i>EIA-RS232-D Support</i>	
Interface Type	Serial asynchronous
Lines Supported	TXD, RXD, RTS, CTS, DSR, DTR (Compatible with CCIT V.24; CCIT V.28)
FTA to Device Distance	15 meters (49 feet) (Cable capacitance = 2500 pF maximum.)
<i>EIA-485 Support</i>	
Interface Type	Serial asynchronous half duplex only
Lines Supported	Two wire differential pair: DATA+, DATA-, Protective GND (shield)
Number of Transceivers	15 drops maximum
FTA to Device Distance	1.2 Km (4000 ft) maximum

# Notices

## Trademarks

Experion®, PlantScape®, SafeBrowse®, TotalPlant®, and TDC 3000® are registered trademarks of Honeywell International, Inc.

ControlEdge™ is a trademark of Honeywell International, Inc.

OneWireless™ is a trademark of Honeywell International, Inc.

Matrikon® and MatrikonOPC™ are trademarks of Matrikon International. Matrikon International is a business unit of Honeywell International, Inc.

Movilizer® is a registered trademark of Movilizer GmbH. Movilizer GmbH is a business unit of Honeywell International, Inc.

## Other trademarks

Microsoft and SQL Server are either registered trademarks or trademarks of Microsoft Corporation in the United States and/or other countries.

Trademarks that appear in this document are used only to the benefit of the trademark owner, with no intention of trademark infringement.

## Third-party licenses

This product may contain or be derived from materials, including software, of third parties. The third party materials may be subject to licenses, notices, restrictions and obligations imposed by the licensor. The licenses, notices, restrictions and obligations, if any, may be found in the materials accompanying the product, in the documents or files accompanying such third party materials, in a file named third\_party\_licenses on the media containing the product, or at <http://www.honeywell.com/ps/thirdpartylicenses>.

## Documentation feedback

You can find the most up-to-date documents on the Honeywell Process Solutions support website at: <http://www.honeywellprocess.com/support>

If you have comments about Honeywell Process Solutions documentation, send your feedback to: [hpsdocs@honeywell.com](mailto:hpsdocs@honeywell.com)

Use this email address to provide feedback, or to report errors and omissions in the documentation. For immediate help with a technical problem, contact your local Honeywell Process Solutions Customer Contact Center (CCC) or Honeywell Technical Assistance Center (TAC).

## How to report a security vulnerability

For the purpose of submission, a security vulnerability is defined as a software defect or weakness that can be exploited to reduce the operational or security capabilities of the software.

Honeywell investigates all reports of security vulnerabilities affecting Honeywell products and services.

To report a potential security vulnerability against any Honeywell product, please follow the instructions at:

<https://www.honeywell.com/product-security>

## Support

## Chapter 10 - MODBUS Interface Reference

---

For support, contact your local Honeywell Process Solutions Customer Contact Center (CCC). To find your local CCC visit the website, <https://www.honeywellprocess.com/en-US/contact-us/customer-support-contacts/Pages/default.aspx>.

## Training classes

Honeywell holds technical training classes that are taught by process control systems experts. For more information about these classes, contact your Honeywell representative, or see <http://www.automationcollege.com>.

# CONTACT US & SUPPORT

NEED A QUOTE OR TECHNICAL PARTS REPLACEMENT?

**Company:** [PLC ProTech Ltd.](#)  
**Website:** [www.plcprotech.com](http://www.plcprotech.com)  
**Email:** [sales@plcprotech.com](mailto:sales@plcprotech.com)  
**Phone:** +86 180 4631 7198

## Our Service Guarantee:

- 100% Brand New Original & Factory Sealed Components
- 12-Month Quality Warranty on All Industrial Parts
- Worldwide Same-Day Fast Dispatch via DHL / FedEx

[SUBMIT ONLINE RFQ \(REQUEST FOR QUOTE\) >>](#)

[About Us](#) · [Contact](#) · [All Products](#)