

3300 5 mm Transducer System

Datasheet

Cordant™

172036 Rev. T

Description

Transducer System

The 3300 5 mm Proximity Transducer System consists of:

- a 3300 5 mm probe 1,2
- a 3300 XL extension cable (ref 141194-01)
- a 3300 XL Proximitor Sensor 3, 4, 5 (ref 141194-01)

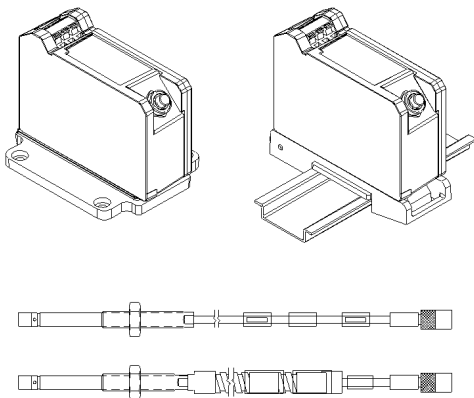

When combined with a 3300 XL Proximitor Sensor and XL extension cable, the system provides an output voltage that is directly proportional to the distance between the probe tip and the observed conductive surface. The system can measure both static (position) and dynamic (vibration) data. Its primary use is in vibration and position measurement applications on fluid-film bearing machines, as well as Keyphasor measurement and speed measurement applications⁶.

The system provides an accurate, stable signal output over a wide temperature range. All 3300 XL Proximity Transducer Systems achieve this level of performance with complete interchangeability of probe, extension cable, and Proximitor sensor, eliminating the need for individual component matching or bench calibration.

Proximity Probe

The 3300 5 mm probe improves upon previous designs. A patented TipLoc molding method provides a more robust bond between the probe tip and the probe body. The 3300 5 mm system is orderable with Fluidloc cable options for preventing oil and other liquids from leaking out of the machine through the cable's interior.



Connectors

The 3300 5 mm probe and 3300 XL extension cable have corrosion-resistant, gold-plated brass ClickLoc connectors. These connectors require only finger-tight torque (connectors will "click"), and the specially engineered locking mechanism prevents the connectors from loosening. The connectors require no special tools for installation or removal.

3300 5 mm Probes and XL Extension Cables can be ordered with connector protectors already installed, or we can supply the connector protectors separately for installation in the field (such as when the cable must be run through restrictive conduit). We recommend connector protectors for all installations to provide increased environmental protection⁷.

Notes:

1. A 5 mm probe uses smaller physical packaging and provides the same linear range as a 3300 XL 8 mm probe (ref 141194-01). The 5 mm probe does not, however, reduce the sideview clearances or tip-to-tip spacing requirements as compared to an XL 8 mm probe. Use the 5 mm probe when physical (not electrical) constraints preclude the use of an 8 mm probe, such as mounting between thrust bearing pads or other constrained spaces. When your application requires narrow sideview probes, use the 3300 XL NSv probe and extension cable with the 3300 XL NSv Proximitor Sensor (refer to Specifications and Ordering Information p/n 147385-01).
2. XL 8 mm probes provide a thicker encapsulation of the probe coil in the molded PPS plastic probe tip to produce a more rugged probe. The larger diameter of the probe body also provides a stronger, more robust case. We recommend the use of XL 8 mm probes when possible to provide optimal robustness against physical abuse.
3. A 3300 XL Proximitor Sensor is available and provides many improvements over the non-XL version. The XL sensor is electrically and mechanically interchangeable with the non-XL version. Although the packaging of the 3300 XL Proximitor Sensor differs from its predecessor, its design allows for the use of a 4-hole mounting base to fit it in the same 4-hole mounting pattern and to fit within the same mounting space specifications (when the application observes the minimum permissible cable bend radius). Consult Specifications and Ordering Information (p/n 141194-01) or our sales and service professional for more information.
4. Use of XL components with 3300 5 mm Probes will limit system performance to the specifications for the non-XL 3300 system.
5. The factory supplies Proximitor Sensors that are calibrated by default to AISI 4140 steel. Calibration to other target materials is available upon request.
6. When using this transducer system for tachometer or over-speed measurements, consult Bently.com for the application note regarding the use of eddy current proximity probes for over-speed protection.
7. We provide silicone tape with each 3300 XL extension cable. Use this tape instead of connector protectors. We do not recommend silicone tape in applications which will expose the probe-to-extension cable connection to turbine oil.

Specifications

Unless otherwise noted, the following specifications are for a proximity transducer system between +18°C and +27°C (+64°F to +80°F) with a -24 Vdc power supply, a 10 kW load, an AISI 4140 steel target, and a probe gapped at 1.27 mm (50 mils).

Electrical

XL Proximator Sensor Input	Accepts one noncontacting 33005 mm Proximity Probe and XL Extension Cable.
Power	Requires -17.5 Vdc to -26 Vdc at 12 mA maximum consumption. Operation at a more positive voltage than -23.5 Vdc can result in reduced linear range.
Supply Sensitivity	Less than 2 mV change in output voltage per volt change in input voltage.
Output Resistance	50 W

Probe DC Resistance	
Probe Length (m)	Resistance from the Center Conductor to the Outer Conductor (Ω)
0.5	7.45 ± 0.50
1.0	7.59 ± 0.50
1.5	7.73 ± 0.50
2.0	7.88 ± 0.50
5.0	8.73 ± 0.70
9.0	9.87 ± 0.90

Extension Cable DC Resistance		
Length of Extension Cable (m)	Resistance from Center Conductor to Center Conductor (R _{CORE}) (Ω)	Resistance from Outer Conductor to Outer Conductor (R _{JACKET}) (Ω)
3.0	0.66 ± 0.10	0.20 ± 0.04
3.5	0.77 ± 0.12	0.23 ± 0.05
4.0	0.88 ± 0.13	0.26 ± 0.05
4.5	0.99 ± 0.15	0.30 ± 0.06
7.0	1.54 ± 0.23	0.46 ± 0.09
7.5	1.65 ± 0.25	0.49 ± 0.10
8.0	1.76 ± 0.26	0.53 ± 0.11
8.5	1.87 ± 0.28	0.56 ± 0.11

 Outer conductor refers to the shielded conductor that is attached to the connector, not the armor braid.

Extension Cable Capacitance	69.9 pF/m (21.3 pF/ft) typical.
Field Wiring	Recommend using 3-conductor shielded triad cable 0.2 mm to 1.5 mm (16 AWG to 24 AWG). 305 meters (1,000 feet) maximum length between 3300 XL Proximity Transducer and monitor. Consult Performance Specification, document 155687, for signal rolloff at high frequencies when using longer field wiring lengths or external safety barriers located some distance from the monitoring system.

3300 5 mm Transducer System
Datasheet

172036 Rev. T

Linear Range	2 mm (80 mils). Linear range begins at approximately 0.25 mm (10 mils) from target and is from 0.25 to 2.3 mm (10 to 90 mils).
Recommended Gap Setting	1.27 mm (50 mils).
Incremental Scale Factor	7.87 V/mm (200 mV/mil) ±6.5% typical, including interchangeability error when measured in increments of 0.25mm (10 mils) over the linear range.
Deviation from Best Fit Straight Line (DSL)	Less than ±0.038 mm (±1.5 mil) typical deviation from best fit straight line.
Probe Temperature Stability (typical)	Over probe temperature range of -35°C to +177°C (-31°F to +350°F), the incremental scale factor remains within ±10% of 7.87 V/mm (200 mV/mil) and the deviation from the best fit straight line remains within ±0.076 mm (±3 mils).
Frequency Response	0 to 10 kHz: +0, -3 dB, with up to 305 meters (1000 feet) of field wiring.
Minimum Target Size	15.2 mm (0.6 in) diameter (flat target)
Shaft Diameter	
Minimum	50.8 mm (2 in)
Recommended minimum	76.2 mm (3 in)

When gapped at the center of the linear range, the interaction between 2 separate transducer systems (cross-talk) will be less than 50 mV on shaft diameters of at least 50 mm (2 in) or greater. Care should be taken to maintain minimum separation of transducer tips, generally at least 40 mm (1.6 in) for axial

position measurements or 38 mm (1.5 in) for radial vibration measurements to limit cross-talk to 50 mV or less. Radial vibration or position measurements on shaft diameters smaller than 76.2 mm (3 in) will generally result in a change in scale factor. Consult Performance Specification 155687 for additional information.

Effects of 60 Hz Magnetic Fields Up to 300 Gauss

Output Voltage in Mil (pk-pk)/Gauss (5-Meter System)			
Gap	XL Proximito Sensor	Probe	XL Ext. Cable
10 mil	0.0119	0.0004	0.0004
50 mil	0.0131	0.0014	0.0014
90 mil	0.0133	0.0045	0.0045

Electrical Certification

Complies with the European CE mark.

Mechanical

Probe Tip Material	Polyphenylene sulfide (PPS)
Probe Case Material	AISI 303 or 304 stainless steel (SST)
Probe Cable	75 Ω triaxial, fluoroethylene propylene (FEP) insulated probe cable in the following lengths: 0.5, 1, 2, 5, or 9 meters (1.6, 3.3, 16.4, or 29.5 feet)
System Length	5 or 9 meters (16.4 or 29.5 feet) including extension cable
Extension Cable Material	75 W triaxial, fluoroethylene propylene (FEP) insulated
Probe and Extension Cable Armor	Flexible AISI 302 or 304 SST with FEP outer jacket

3300 5 mm Transducer System
Datasheet

172036 Rev. T

5mm Probe Tensile Strength	222 N (50 lbf) probe case to probe lead. 222 N (50 lbf) probe lead to extension cable connectors
Connector material	Gold-plated brass or gold-plated beryllium copper
Probe case torque	5.1 N·m (45in·lb) recommended 7.3 N·m (65 in·lb) maximum
Connector-to-connector torque	Refer to the table below: Recommended Torque
Maximum torque	0.565 N·m (0.42 ft·lbf)
Minimum Cable Bend Radius	25.4 mm (1.0in)
Weight	
Total System	0.71 kg (1.6 lb), typical
3300 5mm Probe	323 g (11.39 oz).
XL Extension Cable	34 g/m (0.4 oz/ft) 103 g/m (1.5 oz/ft) (armored)
XL Proximator Sensor	246 g (8.7 oz)

Recommended Torque	
Connector Type	Tightening Instructions
2 3300 XL gold "click" type connectors	Finger tight
1 non-XL stainless steel connector and 1 3300 XL connector	Finger tight plus 1/8 turn using pliers

Thread Engagement Limits

Probe Case Thread	Maximum Length of Thread Engagement
1/4-28	0.375 in
M8x1	12 mm

 Maximum thread engagement lengths are per the industry standard of 1.5 times the nominal thread diameter. A fit class matching that of the external probe thread is assumed for all internal threads. Applications with thread engagement lengths exceeding the values in the table above may exhibit binding during installation. Contact your Bently Nevada representative if you require probe thread engagement lengths exceeding the values above. Bently Nevada does not replace proximity probes under warranty due to excessive thread engagement lengths.

 When drilling and tapping a mounting hole **for a 1/4-28 probe**, a **#3 or larger tap drill** is recommended.

Environmental Limits

Probe Temperature Range	-35°C to +177°C (-31°F to +351°F)
-------------------------	-----------------------------------

 Exposing the probe to temperatures below -34°C (-30°F) may cause premature failure of the pressure seal.

Extension Cable Temperature Range	-51°C to +177°C (-60°F to +351°F) for standard extension cable. ref 141194-01
-----------------------------------	---

3300 5 mm Transducer System
Datasheet

172036 Rev. T

Probe Pressure

3300 5mm probes are designed to seal differential pressure between the probe tip and case. The probe sealing material consists of a fluorocarbon O-ring. We do not pressure test probes prior to shipment. Contact our custom design department if a test of the pressure seal for your application is required.



It is the responsibility of the customer or user to ensure that all liquids and gases are contained and safely controlled should a proximity probe leak. In addition, solutions with high or low pH values may erode the tip assembly of the probe causing media to leak into surrounding areas. Bently Nevada does not be held responsible for any damages resulting from leaking 3300 5 mm proximity probes. In addition, Bently Nevada does not replace 3300 5 mm proximity probes under the service plan due to probe leakage.

Compliance and Certifications

FCC

This device complies with part 15 of the FCC Rules. Operation is subject to the following two conditions:

- This device may not cause harmful interference.
- This device must accept any interference received, including interference that may cause undesired operation.

EMC

EN 61000-6-2

EN 61000-6-4

EMC Directive 2014/30/EU

ATEX (where the applicable dash option has been ordered)

EN 60079-0

EN 60079-11

EN 60079-15

EN 60079-7

ATEX Directive 2014/34/EU

RoHS

RoHS Directive 2011/65/EU

Maritime

ABS 2009 Steel Vessels Rules

1-1-4/7.7,4-8-3/1.11.1,4-9-7/13

Hazardous Area Approvals



For the detailed listing of country and product-specific approvals, refer to the [Approvals Quick Reference Guide \(108M1756\)](#).

For additional technical documentation, please log in to bntechsupport.com and access the Bently Nevada Media Library.

cNRTLus

3300 XL Proximity Sensor

ia	Class I, Zone 0: Aex/Ex ia IIC T4/T5 Ga Class I, Groups A,B,C, and D, Class II, Groups E, F, and G, Class III
When installed with intrinsically safe zener barriers per drawing 141092 or when installed with galvanic isolators.	
nA, ec	Class I, Zone 2: AEx/Ex nA IIC T4/T5 Gc Class I, Division 2, Groups A, B, C, and D Class I, Zone 2 AEx/Ex ec IIC T4/T5 Gc; Class I, Division 2, Groups A, B, C, and D
When installed without barriers per drawing 140979	
T5 @ Ta = -55°C to +40°C	
T4 @ Ta = -55°C to +80°C	

3300 5 mm Transducer System
 Datasheet

172036 Rev. T



3300 XL Probe

ia	Class I, Zone 0: Aex/Ex ia IIC T5...T1 Ga Class I, Groups A,B,C, and D, Class II, Groups E, F, and G, Class III
When installed with intrinsically safe zener barriers per drawing 141092 or when installed with galvanic isolators. (See table below, Temperature Schedule)	
nA, ec	Class I, Zone 2: AEx/Ex nA IIC T5...T1 Gc Class I, Division 2, Groups A, B, C, and D Class I, Zone 2 AEx/Ex ec IIC T5...T1 Gc; Class I, Divison 2, Groups A, B, C, and D
When installed without barriers per drawing 140979 (See table below, Temperature Schedule)	

Ui= -28V	Li= 140 Ma
	T5 @ Ta= -55° C to +40 °C T4 @ Ta= -55 °C to +80 °C



ATEX/IECEx

3300 XL Proximito Sensor

ia	Ex ia IIIC T90C/T105C Dc
	For EPL Dc: T105°C @ Ta = -55°C to 100°C T90°C @ Ta = -55°C to +85°C
	
II 1 G Ex ia IIC T4/T5 Ga	
Ui= -28V li= 140mA Pi= 0.91W Ci- 47nF Li= 1460µH	Uo= -28V lo= 140mA Po= 0.742W Co= 1.5nF Lo= 610µH
nA,ec	
	
II 3 G Ex nA IIC T4/T5 Gc Ex ec IIC T4/T5 Gc	

3300 XL Probe

 Probe entity parameters are met when used with BN extension cables and connected to BN Prox.

ia	Ex ia IIIC T90°C ... T280°C Dc
For EPL Dc: (see Table 5: Temperature Schedule)	
	
II 1 G Ex ia IIC T5...T1 Ga, (see table below, Temperature Schedule)	
Ui = -28V Ci = 1.5 nF li = 140 mA Li = 610 µH Pi = 0.91 W	
nA, ec	
	
II 3 G Ex nA IIC T5...T1 Gc, Ex ec IIC T5...T1 Gc, (see table below, Temperature Schedule).	
Ui = -28V Li= 140 mA	
 The Prox must be installed so as to provide the terminals with a degree of protection of at least IP54.	

Temperature Schedule	
Temperature Classification	Ambient Temperature (Probe Only)
For EPL Ga and Gc	
T1	-55°C to +232°C
T2	-55°C to +177°C
T3	-55°C to +120°C
T4	-55°C to +80°C
T5	-55°C to +40°C
For EPL Dc	
T280C @ Ta	-55°C to +232°C
T225C @ Ta	-55°C to +177°C
T170C @ Ta	-55°C to +120°C
T130C @ Ta	-55°C to +80°C
T90C @ Ta	-55°C to +40°C

Zone 2:

1. This product is not resistant to light as required by the relevant clause of EN 60079-0, therefore, it shall only be installed in a location where it is not exposed to direct sunlight or any other source of ultra-violet (UV) light.
2. The connector shall not be disconnected while the circuit is live unless the area is known to be non-hazardous.
3. The end user is to ensure appropriate earthing upon installation.

Hazardous Area Conditions of Safe Use

Zone 0/1:

1. The exposed plastic surface of the Probes with 50 mm diameter, under certain extreme circumstances, may generate an ignition-capable level of electrostatic charge. Therefore, this version of the equipment shall not be installed in a location where the external conditions are conducive to the build-up of electrostatic charge on the plastic surface. In addition, the equipment shall only be cleaned with a damp cloth. This is particularly important if the equipment is installed in a Zone 0 location.
2. The end user is to ensure appropriate earthing upon installation.

Ordering Information



For the detailed listing of country and product-specific approvals, refer to the [Approvals Quick Reference Guide \(108M1756\)](#).

For additional technical documentation, please log in to bntechsupport.com and access the Bently Nevada Media Library.

3300 5mm Proximity Probes

330171 3300 5mm Probe, 1/4-28 UNF thread, without armor

330172 3300 5mm Probe, 1/4-28 UNF thread, with armor

Part Number-AA-BB-CC-DD-EE

A: Unthreaded Length Option



Unthreaded length must be at least 0.8 in. less than the case length. Order in increments of 0.1 in.

Length configurations: Maximum unthreaded length:
8 8 = 8.8 in. Minimum unthreaded length:
0 0 = 0.0 in.
Example: 0 4 = 0.4 in.

B: Overall Case Length Option

Order in increments of 0.1 in. **Threaded Length configurations:**
Maximum unthreaded length: **9 6** = 9.6 in.
Minimum unthreaded length: **0 8** = 0.8 in.
Example: 2 4 = 2.4 in.

C: Total Length Option

0 5	0.5 meter (1.6 feet)
1 0	1.0 metre (3.3 feet)

2 0	2.0 metres (6.6 feet)
5 0	5.0 metres (16.4 feet) ¹
9 0	9.0 metres (29.5 feet)

D: Connector Option

0 1	Miniature coaxial ClickLoc connector with connector protector, standard cable
0 2	Miniature coaxial ClickLoc connector, standard cable
1 1	Miniature coaxial ClickLoc connector with connector protector, FluidLoc cable
1 2	Miniature coaxial ClickLoc connector, FluidLoc cable

E: Agency Approval Option

0 0	Agency Approval Option
0 5	Multiple Approvals

3300 5mm Proximity Probes, Metric

330173 3300 5mm Probe, M8 x 1 thread, without armor

330174 3300 5mm Probe, M8 x 1 thread, with armor

Part Number-AA-BB-CC-DD-EE

A: Unthreaded Length Option



Unthreaded length must be at least 20mm less than the case length. Order in increments of 10mm.

Length configurations: |
Maximum unthreaded length: **2 3** = 230mm
Minimum unthreaded length: **0 0** = 0.0mm
Example: 0 6 = 60mm

3300 5 mm Transducer System
 Datasheet

172036 Rev. T

B: Overall Case Length Option

Order in increments of 10mm

Metric thread configurations:

Maximum unthreaded length: **2 5** = 250mm

Minimum unthreaded length: **0 2** = 20mm

Example:0 6 = 60mm

C: Total Length Option

0 5	0.5 meter (1.6 feet)
1 0	1.0 metre (3.3 feet)
2 0	2.0 metres (6.6 feet)
5 0	5.0 metres (16.4 feet) ¹
9 0	9.0 metres (29.5 feet)

D: Connector Option

0 1	Miniature coaxial ClickLoc connector with connector protector, standard cable
0 2	Miniature coaxial ClickLoc connector, standard cable
1 1	Miniature coaxial ClickLoc connector with connector protector, FluidLoc cable
1 2	Miniature coaxial ClickLoc connector, FluidLoc cable

E: Agency Approval Option

0 0	Agency Approval Option
0 5	Multiple Approvals

Ordering Information for Proximator Sensor

3300 XL Proximator Sensor

330180-AA-BB

A: Total Length and Mounting Option

10	1.0 meter (3.3 feet) system length, panel mount
-----------	---

11	1.0 meter (3.3 feet) system length, DIN mount
12	1.0 meter (3.3 feet) system length, no mounting hardware
50	5.0 meters (16.4 feet) system length, panel mount
51	5.0 meters (16.4 feet) system length, DIN mount
52	5.0 meters (16.4 feet) system length, no mounting hardware
90	9.0 meters (29.5 feet) system length, panel mount
91	9.0 meters (29.5 feet) system length, DIN mount
92	9.0 meters (29.5 feet) system length, no mounting hardware

B: Agency Approval Option

00	Not required
05	CSA, ATEX, IECEx Approvals

Ordering Information for Extension Cables

3300 XL Standard Extension Cable

330130-AAA-BB-CC



Make sure that the extension cable length and the probe length, when added together, equal the Proximator Sensor total length.

A: Cable Length Option

030	3.0 meters (9.8 feet)
035	3.5 meters (13.1 feet)
040	4.0 meters (11.5 feet)
045	4.5 meters (14.8 feet)

3300 5 mm Transducer System
 Datasheet

172036 Rev. T

060	6.0 meters (19.7 feet)
070	7.0 meters (22.9 feet)
075	7.5 meters (24.6 feet)
080	8.0 meters (26.2 feet)
085	8.5 meters (27.9 feet)

B: Connector Protector and Cable Option

00	Standard cable
01	Armored cable
02	Standard cable with connector protector
03	Armored cable with connector protector
10	FluidLoc cable
11	Armored FluidLoc cable
12	FluidLoc cable with connector protector
13	Armored FluidLoc cable with connector protector

C: Agency Approval Option

00	Not required
05	CSA, ATEX, IECEx Approvals

Probe Accessories

Aluminum probe mounting bracket

The aluminum probe threaded mounting bracket is the standard mounting bracket for most 3300 5 mm probe installations. The -02 option is supplied with 2 10-24 UNC-2A mounting screws. The -03 option is supplied with 2 M5 x 0.8-6g mounting screws. The mounting screws have pre-drilled holes for safety wire.

137492 -AA

A: Thread Size

0 2	1/4-28
0 3	M8 x 1

Phenolic Probe Mounting Bracket

The phenolic mounting bracket is recommended if additional electric isolation from the mounting location is required (as in some generator and electrical motor bearing locations). The -02 option is supplied with 2 10-24 UNC-2A mounting screws. The -03 option is supplied with 2 M5 x 0.8-6g mounting screws. The mounting screws have pre-drilled holes for safety wire.

27474 -AA

A: Thread Size

0 2	1/4-28
0 3	M8 x 1

75Ω ClickLoc Connector Kit

330153-AA

75Ω ClickLoc Connector Kit for 3300 series probes and extension cables. Each kit contains 1 color-coded sleeve per connector.

A: Kit Type

0 2	1 ClickLoc male connector for 3300 XL 5mm and 8mm extension cable.
0 3	1 ClickLoc female connector for 3300 XL 5mm and 8mm extension cable.
0 4	1 ClickLoc male connector for 3300 5mm probe.

3300 5 mm Transducer System
Datasheet

172036 Rev. T

Accessories

02120015	<p>Bulk field wire</p> <p>1.0mm² (18 AWG), 3-conductor, twisted, shielded cable for connections between Proximitor Sensor and monitor.</p>	03800001	<p>75Ω Coaxial Female Connector Protector</p> <p>Placed onto 3300 5mm probe leads; attaches to the male connector protector on the extension cable to provide environmental protection of connectors.</p>
03200006	<p>Silicone self-fusing tape</p> <p>9.1-metre (10-yard) roll of silicone tape to protect connectors. It is easy to install and provides excellent electrical isolation and protection from the environment. It is not recommended for use inside the casing of the machine.</p>	163356	<p>Connector Crimp Tool Kit</p> <p>Includes 1 set of multi-connector inserts and connector installation instructions. Compatible only with 330153 connector kits or with probes shipped in 2003 or later with ClickLoc connectors uninstalled. Supplied with carrying case.</p>
40113-03	<p>Connector Protector Kit</p> <p>Connector Protector Kit for 3300 5mm probes, including connector protectors and installation tools.</p>		
136536-01	<p>Connector Protector Adapter</p> <p>Makes connector protector kits purchased prior to 1998 compatible with ClickLoc extension cable connectors.</p>		
40180-03	<p>Connector Protectors</p> <p>Package containing 10 pairs of 75Ω Coaxial Connector Protectors.</p>		
03839410	<p>75Ω Triaxial/95 ohm Coaxial Male Connector Protector</p> <p>Placed onto the extension cable; attaches to the female connector protector on the 5 mm probe to provide environmental protection of connectors.</p>		

Graphs and Figures

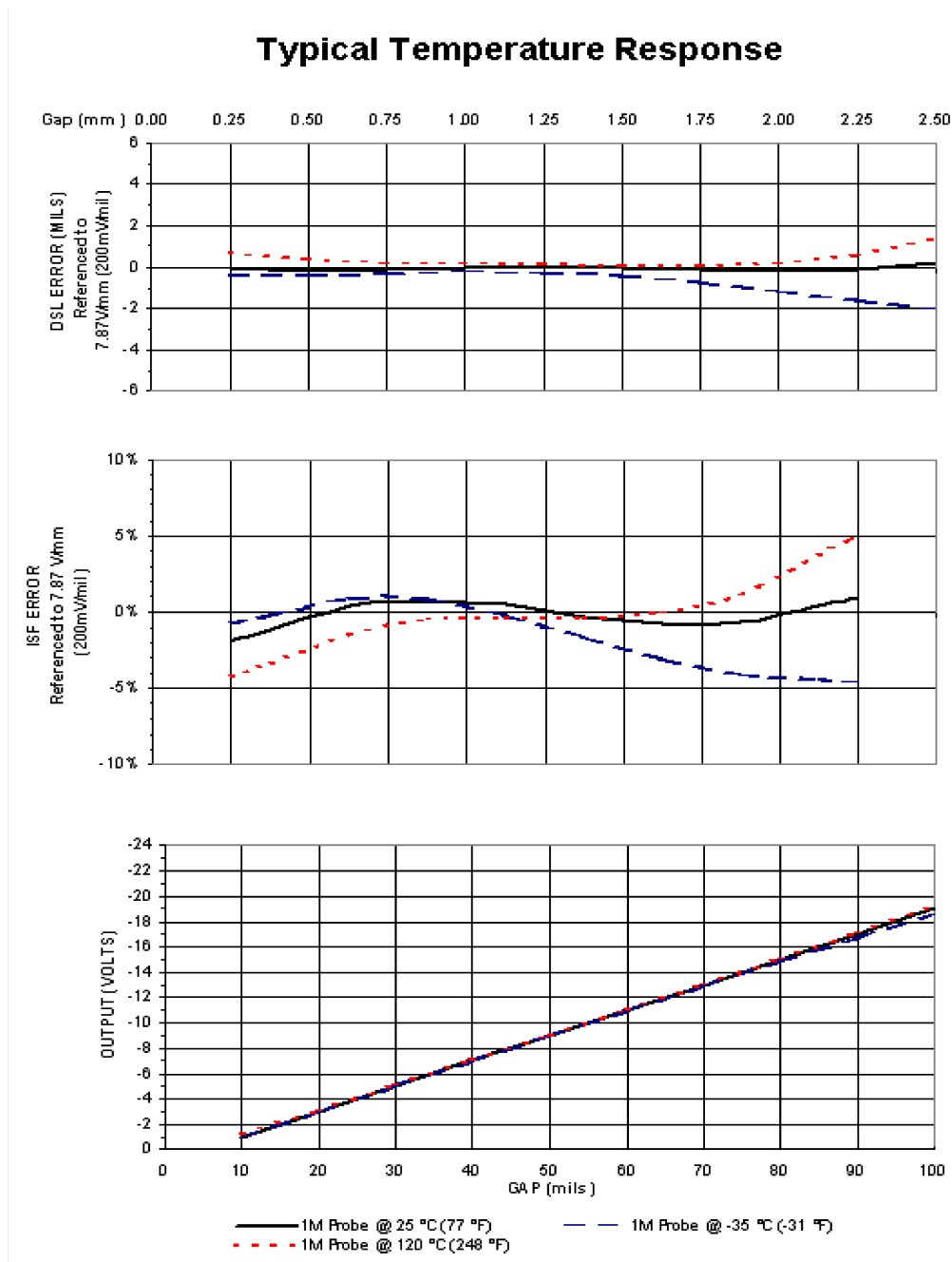

Figure 1: Typical 3300 5mm Probe and 1 Metre of Cable at High and Low Temperatures (XL Proximitor Sensor and XL Extension Cable are at 25°C)

Typical Temperature Response

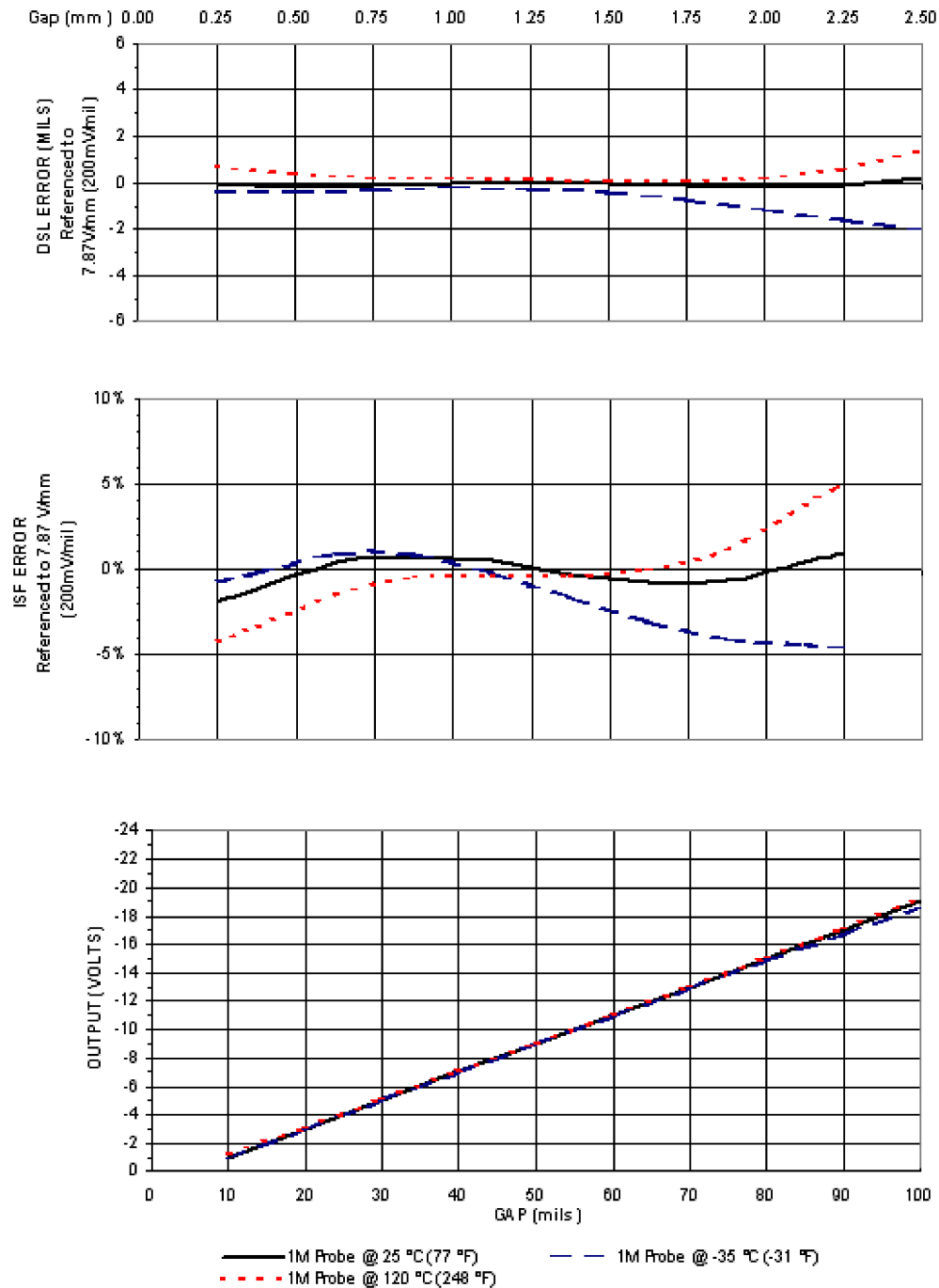
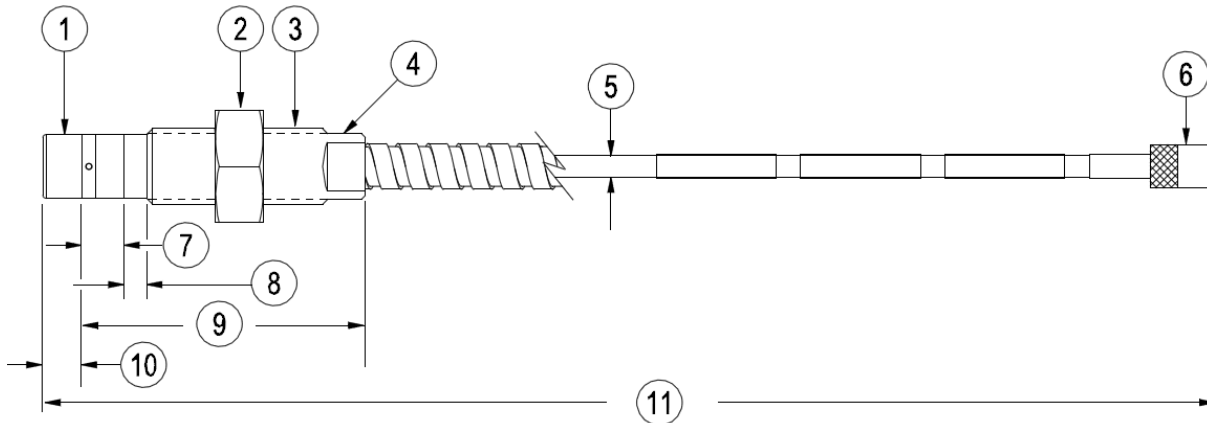

Figure 2: 3300 5 Meter XL Proximitor Sensor at High Temperatures (3300 5mm Probe and XL Extension Cable at 25°C)



1. Probe tip, 5.2mm [0.21 in] diameter
2. 11.1 mm [7/16in] for 1/4-28 threads, 13.0mm [0.51in] for M8 thread. See Note 3.
3. Case thread
4. 5.6 [7/32] wrench flats for 1/4-28 threads, 7.0 [0.28] for M8 threads
5. 75Ω cable, 2.8mm [0.11 in] maximum outside diameter, 7.6mm [0.3 in] outside diameter of armor, 9.0mm [0.35in] maximum diameter of armor ferrule.
6. Miniature male coaxial connector, 7.23mm [0.285 in] maximum outside diameter "D"
7. 3.2 [0.13in]
8. Unthreaded length "A"
9. Case length "B"
10. 6.0mm [0.235in] maximum
11. Total length "C", =30%, -0%. See Note.

Figure 3: 3300 5mm Proximity Probes, Standard Mount³

330171, 1/4-28 UNF-2A, without armor⁷

330172, 1/4-28 UNF-2A, with armor⁶

330173, M8X1 thread, without armor⁷

330174, M8X1 thread, with armor⁶

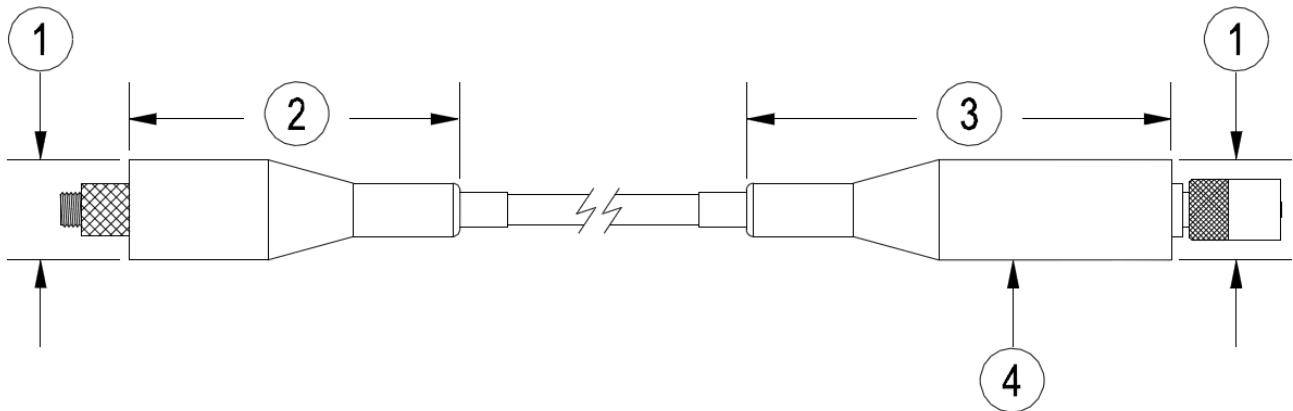

1. 12mm [0.40in] maximum diameter
2. 36.3mm [1.43in] maximum
3. 51.1mm [2.01in] maximum
4. Connector protector (fluorosilicone material)

Figure 4: Installed Connector Protectors

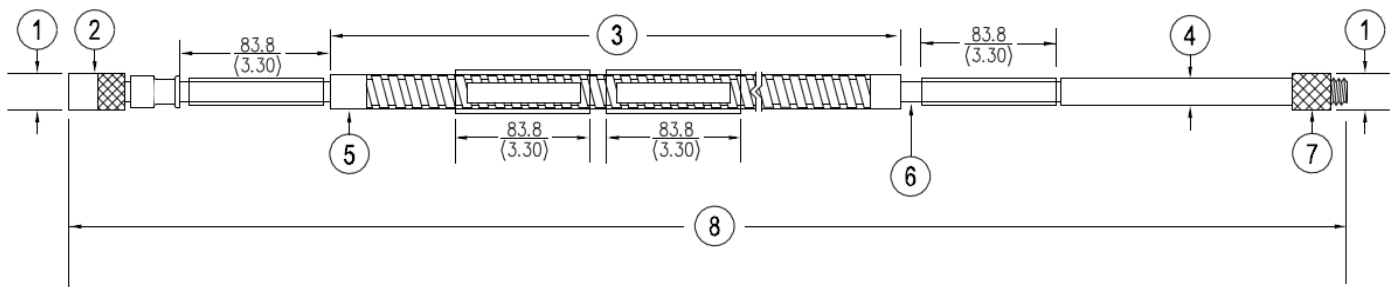

1. 7.2mm [0.25 in] maximum diameter
2. Miniature male coaxial connector
3. FEP or PFA coated armor. Armor length is 300mm [11.8in] less than cable length. See Note 5.
4. 75Ω cable, 3.7mm [0.15 in] maximum outside diameter, 3.9mm [0.16in] maximum diameter for FluidLoc cable, 7.6mm [0.30in] maximum outside diameter or armor, 9.0mm [0.35in] maximum diameter of armor ferrule.
5. Stainless steel ferrules, 8.4mm [0.33in] diameter
6. Miniature female coaxial connector
7. Cable length, +20%, -0%

Figure 5: 3300 XL Extension Cable

330130, 3300 XL Extension Cable (FEP armor and insulation)

1. All dimensions are in millimetres (inches) unless otherwise noted.
2. Standard mount 5mm probes supplied with 13 mm or 7/16-in lock nut.
3. Letters inside quotation marks refer to probe ordering options.
4. Stainless steel armor is supplied with FEP outer jacket for standard probes, PFA outer jacket for ETR probes.
5. FEP jacket is standard non-armored portion of the cable for standard probes, PFA jacket on non-armored portion for ETR probes.
6. Probes ordered with 5 or 9 meter integral cables have a length tolerance of +20%, -0%.
7. Five meter probes are designed for use with the five meter Proximity Sensor only.

3300 5 mm Transducer System
Datasheet

172036 Rev. T

Copyright 2025 Baker Hughes Company. All rights reserved.

Bently Nevada, a Baker Hughes Company
1631 Bently Parkway South, Minden, Nevada USA 89423
<https://bntechsupport.com>

CONTACT US & SUPPORT

NEED A QUOTE OR TECHNICAL PARTS REPLACEMENT?

Company: [PLC ProTech Ltd.](#)
Website: www.plcprotech.com
Email: sales@plcprotech.com
Phone: +86 180 4631 7198

Our Service Guarantee:

- 100% Brand New Original & Factory Sealed Components
- 12-Month Quality Warranty on All Industrial Parts
- Worldwide Same-Day Fast Dispatch via DHL / FedEx

[SUBMIT ONLINE RFQ \(REQUEST FOR QUOTE\) >>](#)

[About Us](#) · [Contact](#) · [All Products](#)