

3500/70M Recip Impulse Velocity Monitor

Datasheet

Cordant™

166766 Rev. T

Description

The Bently Nevada™ 3500/70M Recip Impulse Velocity Monitor is a 4-channel device used as part of the reciprocating compressor solutions package to monitor compressor crankcase and crosshead vibration. The monitor accepts input from seismic transducers, conditions the signal to derive vibration measurements, and compares the conditioned signals with user-programmable alarms.

You can program each channel using the 3500 Rack Configuration Software to perform the following functions:

- Impulse Acceleration
- Acceleration 2
- Recip Velocity
- Low Frequency Recip Velocity



The monitor channels are programmed in pairs and can perform up to two of the aforementioned functions at a time. For example, channels 1 and 2 can perform one function while channels 3 and 4 perform another or the same function.

The primary purpose of the 3500/70M Recip Impulse Velocity Monitor is to provide the following:

- Machinery protection for reciprocating compressors by continuously comparing monitored parameters against configured alarm setpoints to drive alarms
- Essential reciprocating compressor machine information for both operations and maintenance personnel

Each channel, depending on configuration, typically conditions its input signal to generate various parameters called static values. You can configure alert setpoints for each active static value and danger setpoints for any two of the active static values.



3500/70M Recip Impulse Velocity Monitor
Datasheet

166766 Rev. T

Specifications

Inputs

Signal	Accepts from 1 to 4 proximity probe signals.
Input impedance	10 k Ω acceleration input >1 M Ω velocity input
Special inhibit	Contact closure 5 Vdc @ 390 μ A typical
Power consumption	7.7 watts, nominal

Sensitivity

Impulse acceleration	0.51 – 11.72 mV/(m/s ²) 5 – 115 mV/g
Acceleration 2	0.51 – 11.72 mV/(m/s ²) 5 – 115 mV/g
Recip velocity	3.54 – 22.64 mV/(mm/s) 90 – 575 mV/(in/s)
Low Frequency Recip velocity	3.54 – 22.64 mV/(mm/s) 90 – 575 mV/(in/s)

Outputs

Front Panel LEDs

OK LED	Indicates when the 3500/70M Recip Impulse Velocity Monitor is operating properly.
TX/RX LED	Indicates when the 3500/70M Recip Impulse Velocity Monitor is communicating with other modules in the 3500 rack.
Bypass LED	Indicates when the 3500/70M Recip Impulse Velocity Monitor is in Bypass Mode.

Transducer Power Supply

Voltage	-22 Vdc minimum
---------	-----------------

Current	40 mA maximum 15 mA maximum on startup to guarantee no fold back
Output impedance	20 Ω typical operating 1000 Ω typical under fold back conditions
Protection	Foldback current 15.4 to 24.9 mA

Front Panel Buffered Outputs

Buffered Transducer Outputs	The front of each monitor has one coaxial connector for each channel.
Output Impedance	550 Ω typical
Protection	Each connector is short-circuit protected.

Recorder Outputs

Recorder	+4 to +20 mA proportional to monitor full-scale. Selects one static data value from each channel to be used for that channel's recorder value.
Voltage compliance	+12 Vdc maximum
Load resistance	600 Ω maximum
Resolution	0.3662 μ A maximum
Update rate	<100 millisecond
Accuracy	Within \pm 0.05 mA. \pm 0.14 mA over temperature range.

3500/70M Recip Impulse Velocity Monitor
 Datasheet

166766 Rev. T

Signal Conditioning



Specified at +25°C (+77°F) unless otherwise noted.

Impulse Acceleration

Accuracy	Within ± 0.33% of full-scale typical, ± 1% maximum Exclusive of filters
Band start	0 to 359° 1° resolution
Band duration	1 to 360° 1° resolution

Frequency Response

Bias filter	-3 dB at 0.01 Hz 1-pole Low-Pass
Not OK filter	-3 dB at 2400 Hz 1-pole Low-Pass
Static values	Smoothing filter 8-revolution average value

Filter Quality

High-pass	4-pole 80 dB per decade 24 dB per octave
Low-pass	4-pole 80 dB per decade 24 dB per octave

Corner Selection	Peak 3 dB Corner	RMS 3 dB Corner
High-pass	3 - 3000 Hz	10 - 3000 Hz
Low-pass	30 - 30000 Hz	40 - 30000 Hz

Acceleration 2

Accuracy	Within ± 0.33% of full-scale typical ± 1% maximum Exclusive of filters
----------	--

Frequency Response

Bias filter	-3 dB at 0.01 Hz 1-pole Low-Pass
Not OK filter	-3 dB at 2400 Hz 1-pole Low-Pass
Peak static values	-3 dB at 0.3 Hz 1-pole Low-Pass
RMS static values	-3 dB at 0.1 Hz 1-pole Low-Pass

Filter Quality

High-pass	4-pole 80 dB per decade 24 dB per octave
Low-pass	4-pole 80 dB per decade 24 dB per octave

Corner Selection	Pk 3 dB Corner	RMS 3 dB Corner	Integrate 3 dB Corner
High-pass	3 - 3000 Hz	10 - 3000 Hz	3-3000 Hz
Low-pass	30-30000 Hz	40 - 30000 Hz	40-20000 Hz

Recip Velocity

Accuracy	Within ± 0.33% of full-scale typical ± 1% maximum Exclusive of filters
----------	--

3500/70M Recip Impulse Velocity Monitor
Datasheet

166766 Rev. T

Velomitor	Additional accuracy degradation occurs when full scale signal levels are low: Full Scale 0-0.5: ±3% typical Full Scale 0-1.0: ±2% typical Full Scale 0-2.0: ±1% typical
-----------	--

Frequency Response

Bias filter	-3 dB at 0.01 Hz 1-pole Low-Pass
Not OK filter	-3 dB at 2400 Hz 1-pole Low-Pass
Integration filter	-3 dB at 0.34 Hz 1-pole Low-Pass
RMS static values	-3 dB at 0.1 Hz 1-pole Low-Pass
Peak static values	-3 dB at 0.3 Hz 1-pole Low-Pass
1X & 2X Vector Filter	Constant Q filter with bandwidth = ±3% running speed Q = 16.7

Filter Quality

High-pass	4-pole 80 dB per decade 24 dB per octave
Low-pass	2-pole 40 dB per decade 12 dB per octave

Corner Selection	Pk 3 dB Corner	RMS 3 dB Corner	Integrate 3 dB Corner
High-pass	1- 400 Hz	10-400 Hz	3-400 Hz
Low-pass	40-5500 Hz	60-5500 Hz	40-5500 Hz

Low Frequency Recip Velocity

Accuracy	Within ± 0.33% of full-scale typical ± 1% maximum Exclusive of filters
Velomitor	Additional accuracy degradation occurs when full scale signal levels are low: Full Scale 0-0.5: ±3% typical Full Scale 0-1.0: ±2% typical Full Scale 0-2.0: ±1% typical

Frequency Response

Bias filter	-3 dB at 0.01 Hz 1-pole Low-Pass
Not OK filter	-3 dB at 2400 Hz 1-pole Low-Pass
Integration filter	-3 dB at 0.34 Hz 1-pole Low-Pass
RMS static values	-3 dB at 0.1 Hz 1-pole Low-Pass
Peak static values	-3 dB at 0.3 Hz 1-pole Low-Pass
1X & 2X Vector Filter	Constant Q filter with bandwidth = ±3% running speed Q = 16.7

Filter Quality

High-pass	4-pole 80 dB per decade 24 dB per octave
Low-pass	2-pole 40 dB per decade 12 dB per octave

3500/70M Recip Impulse Velocity Monitor
 Datasheet

166766 Rev. T

Corner Selection	Peak and Integrate 3 dB Corner	RMS 3 dB Corner
High-pass	0.750 - 100 Hz	0.750 - 100 Hz
Low-pass	10 - 1375 Hz	15 - 1375 Hz

Rack Space Requirements

Monitor	1 full-height front slot
I/O Modules	1 full-height rear slot

Physical

Monitor Module (Main Board)

Dimensions (Height x Width x Depth)	241.3 mm x 24.4 mm x 241.8 mm (9.50 in x 0.96 in x 9.52 in)
Weight	0.91 kg (2.0 lb)

I/O Modules (non-barrier)

Dimensions (Height x Width x Depth)	241.3 mm x 24.4 mm x 99.1 mm (9.50 in x 0.96 in x 3.90 in)
Weight	0.20 kg (0.44 lb)

I/O Modules (barrier)

Dimensions (Height x Width x Depth)	241.3 mm x 24.4 mm x 163.1 mm (9.50 in x 0.96 in x 6.42 in)
Weight	0.46 kg (1.01 lb)

Alarms

Alarm Setpoints	Use Rack Configuration Software to set alert levels for each value measured by the monitor and danger setpoints for any two of the values measured by the monitor. Alarms are adjustable from 0 to 100% of full-scale for each measured value. However, when the full-scale range exceeds the range of the transducer, the range of the transducer will limit the setpoint.
Accuracy of alarm setpoints	Within 0.13% of the desired value

Alarm Time Delays

You can program alarm delays using 3500 Rack Configuration Software.

Alert	From one to 60 seconds in one second intervals
Danger	0.1 seconds (nominal) or from one to 60 seconds in one second intervals

Static Values

Static values are measurements used to monitor the machine. The 3500/70M Recip Impulse Velocity Monitor returns static values from the following channels:

Impulse Acceleration	Direct Bias Voltage Six user-adjustable crank angle bands with peak or RMS acceleration in the band
----------------------	---

3500/70M Recip Impulse Velocity Monitor
 Datasheet

166766 Rev. T

Acceleration 2	Direct 1X Amplitude 2X Amplitude 1X Phase 2X Phase Bias Voltage
Recip Velocity	Direct 1X Amplitude 2X Amplitude 1X Phase 2X Phase Bias Voltage
Low Frequency Recip Velocity	Direct 1X Amplitude 2X Amplitude 1X Phase 2X Phase Bias Voltage



Bias voltage contains no information about the condition of the machinery being monitored. It is provided for monitor system diagnostics.

Barrier Parameters

The following parameters apply to CSA-NRTL/C and CENELEC approvals.

Proximator Barrier

Circuit Parameters	Vmax (PWR) = 26.80 V (SIG) = 14.05 V Imax (PWR) = 112.8 mA (SIG) = 2.82 mA Rmin (PWR) = 237.6 Ω (SIG) = 4985 Ω
Channel Parameters (Entity)	Vmax = 28.0 V Imax = 115.62 mA Rmin (PWR) = 237.6 Ω (SIG) = 4985 Ω

Seismic Barrier

Circuit Parameters	Vmax (PWR) = 27.25 V Imax (PWR) = 91.8 mA Rmin (PWR) = 297 Ω
Channel Parameters (Entity)	Vmax = 27.25 V Imax = 91.8 mA Rmin (PWR) = 297 Ω

Environmental Limits

Operating Temperature	When used with Internal / External Termination Proximator / Seismic I/O Module: -30°C to +65°C (-22°F to +149°F)
	When used with Proximator / Seismic Internal Barrier I/O Module (Internal Termination) 0°C to +65°C (32°F to +149°F)
Storage Temperature	-40°C to +85°C (-40°F to +185°F)
Humidity	95% Non-condensing

Compliance and Certifications

FCC

This device complies with part 15 of the FCC Rules. Operation is subject to the following two conditions:

- This device may not cause harmful interference.
- This device must accept any interference received, including interference that may cause undesired operation.

EMC

European Community Directive:

EMC Directive 2014/30/EU

Standards:

EN 61000-6-2; Immunity for Industrial Environments
EN 61000-6-4; Emissions for Industrial Environments

Electrical Safety

European Community Directive:

LV Directive 2014/35/EU

Standards:

EN 61010-1

RoHS

European Community Directive:

RoHS Directive 2011/65/EU

China RoHS

Cables associated with the product(s) mentioned in this datasheet have an EFUP designation of 15 years, in accordance with SJ/T 11364-2024.



Maritime

DNV GL rules for classification – Ships, offshore units, and high speed and light craft

ABS Rules for Condition of Classification, Part 1

- Steel Vessels Rules
- Offshore Units and Structures

3500/70M Recip Impulse Velocity Monitor
 Datasheet

166766 Rev. T

Hazardous Area Approvals



For the detailed listing of country and product-specific approvals, refer to the [Approvals Quick Reference Guide \(108M1756\)](#).

For additional technical documentation, please log in to bntechsupport.com and access the Bently Nevada Media Library.

When used with I/O module ordering options with internal barriers	 <p>II 3(1) G Ex nA nC ic [ia Ga] IIC T4 Gc; Ex ec nC ic [ia Ga] IIC T4 Gc; T4 @ Ta= -20°C to +65°C (-4°F to +149°F) When installed per drawing 138547.</p>
---	--

cNRTLus

When used with I/O module ordering options without internal barriers	<p>Class I, Zone 2: AEx/Ex nA nC ic IIC T4 Gc; Class I, Zone 2: AEx/Ex ec nC ic IIC T4 Gc; Class I, Division 2, Groups A, B, C, and D;</p> <p>T4 @ Ta= -20°C to +65°C (-4°F to +149°F) When installed per drawing 149243 or 149244.</p>
When used with I/O module ordering options with internal barriers	<p>Class I, Zone 2: AEx/Ex nA nC ic [ia Ga] IIC T4 Gc; Class I, Zone 2: AEx/Ex ec nC ic [ia Ga] IIC T4 Gc; Class I, Division 2, Groups A, B, C, and D (W/ IS Output for Division 1)</p> <p>T4 @ Ta= -20°C to +65°C (-4°F to +149°F) When installed per drawing 138547.</p>

ATEX/IECEx

When used with I/O module ordering options without internal barriers	 <p>II 3 G Ex nA nC ic IIC T4 Gc; Ex ec nC ic IIC T4 Gc;</p> <p>T4 @ Ta= -20°C to +65°C (-4°F to +149°F) When installed per drawing 149243 or 149244.</p>
--	---

Ordering Considerations

- For I/O modules with External Terminations, order the External Termination Blocks and cable separately for each I/O module.
- For the Internal Barriers, refer to the 3500 Internal Barrier datasheet, document 141495.
- External Termination Blocks cannot be used with Internal Termination I/O Modules.



The lower limit for machine speed is 60 RPM in standard product. For machine speeds down to 30 RPM, modification 135M8137-01 is required.

Software Compatibility

3500/01 Configuration Software	Version 5.2 or later
3500/02 Data Acquisition Software	Version 2.50 or later
3500/03 Operator Display Software	Version 1.50 or later
System1 Software	Version 6.90 or later

Firmware Compatibility

3500/70M Firmware	Version 4.21 or later
3500/22M TDI Firmware	Version 1.75 or later
3500/22M USB TDI Firmware	Version 4.05 or later

Ordering Information



For the detailed listing of country and product-specific approvals, refer to the [Approvals Quick Reference Guide \(108M1756\)](#).

For additional technical documentation, please log in to bntechsupport.com and access the Bently Nevada Media Library.

Recip Impulse / Velocity Monitor 3500/70M - AA-BB

A: I/O Module Type

01	Prox/Velom I/O Module with Internal Terminations
02	Prox/Velom I/O Module with External Terminations
03	Internal Barrier, Four Accelerometers
04	Internal Barrier, Two Accelerometers, Two Velomitors
05	Internal Barrier, Four Velomitors

B: Agency Approval

00	None
01	cNRTLus (Class 1, Division 2)
02	ATEX/ IECEx/ CSA (Class 1, Zone 2)



Order the Earthing Module for each rack with internal barriers.

External Termination Blocks

Part Number	Description
128702-01	Recorder External Termination Block Euro Style connectors

3500/70M Recip Impulse Velocity Monitor
Datasheet

166766 Rev. T

Part Number	Description
128710-01	Recorder External Termination Block Terminal Strip connectors
125808-08	Proximator / Velomitor External Termination Block Euro Style connectors
128015-08	Proximator / Velomitor External Termination Block Terminal Strip connectors

Cables

3500 Transducer (XDCR) to External Termination (ET) Block Cable

129525 - AAAA-BB

A: I/O Cable Length

0005	5 feet (1.5 meters)
0007	7 feet (2.1 meters)
0010	10 feet (3.0 meters)
0025	25 feet (7.6 meters)
0050	50 feet (15.2 meters)
0100	100 feet (30.5 meters)

B: Assembly Instructions

01	Not assembled
02	Assembled

3500 Recorder Output to External Termination (ET) Block Cable

129529-AAAA-BB

A: I/O Cable Length

0005	5 feet (1.5 meters)
------	---------------------

0007	7 feet (2.1 meters)
0010	10 feet (3.0 meters)
0025	25 feet (7.6 meters)
0050	50 feet (15.2 meters)
0100	100 feet (30.5 meters)

B: Assembly Instructions

01	Not assembled
02	Assembled

Spares

Part Number	Description
176449-09	3500/70M Recip Impulse Velocity Monitor
166226-01	3500/70M Recip Impulse Velocity Monitor User Manual
135489-01	I/O Module with Internal Barriers, Internal Terminations 4 x Prox/Accel
135489-02	I/O Module with Internal Barriers, Internal Terminations 2 x Prox/Accel and 2 x Velomitor
135489-03	I/O Module with Internal Barriers, Internal Terminations 4 x Velomitor
140471-01	Prox/Velom I/O Module with Internal Terminations
140482-01	Prox/Velom I/O Module with External Terminations
00561941	3500/70M Prox/Velom I/O Module ten-pin connector shunt

3500/70M Recip Impulse Velocity Monitor
Datasheet

166766 Rev. T

Part Number	Description
00580434	Internal I/O Module connector header Euro Style, 8 pin For I/O modules 128229-01 and 138708-01
00580432	Internal I/O Module connector header Euro Style, 10 pin For I/O modules 128229-01, 138708-01
00502133	Internal I/O Module connector header Euro Style, 12 pin
166M2389	Connector header Push-in-spring type (Alternative for PN 00580434)
166M2388	Connector header Push-in-spring type (Alternative for PN 00580432)

Graphs and Figures

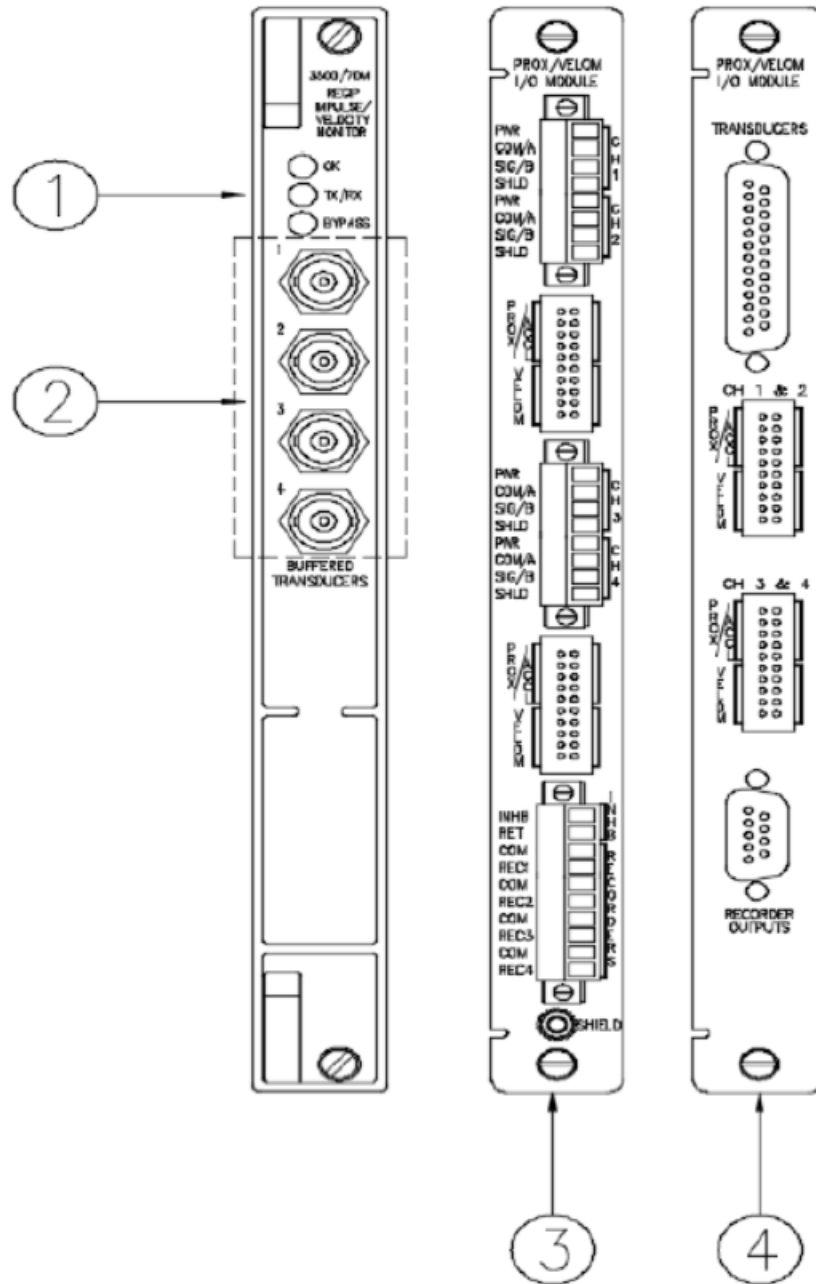

1. Status LEDs
2. Buffered Transducer Outputs
3. Prox/Velom I/O Module, Internal Termination, 140471-01
4. Prox/Velom I/O Module, External Termination, 140482-01

Figure 1: 3500/70M Front and Rear Views

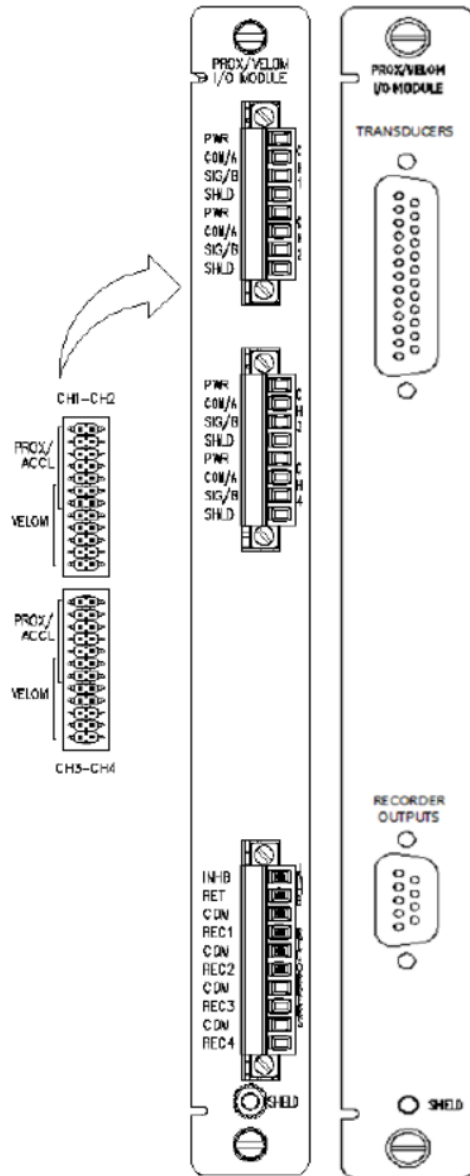

The I/O modules with internal or external terminations have the same jumpers.

Figure 2: Side View of I/O Modules

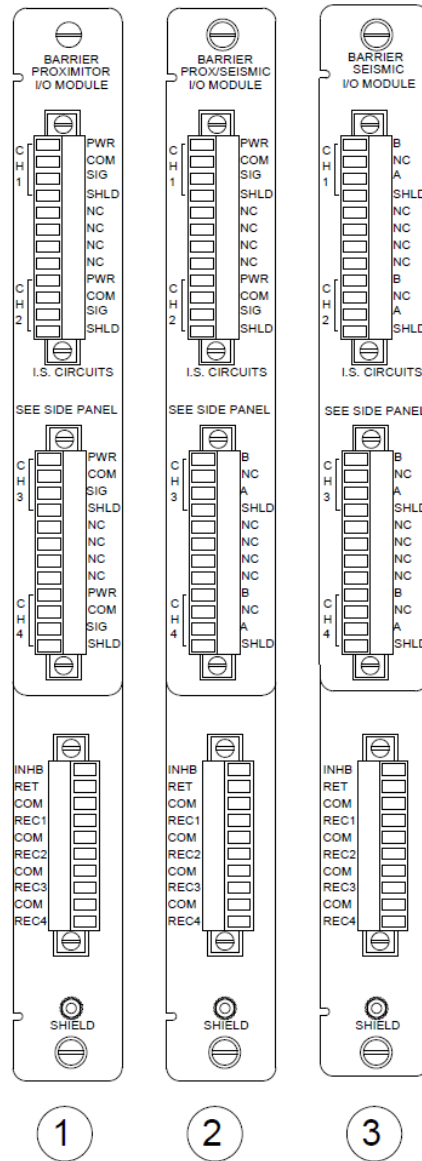

1. Barrier I/O module to connect four Accelerometer sensors, 135489-01
2. Barrier I/O module to connect two Accelerometer sensors and two Velomitor sensors, 135489-02
3. Barrier I/O module to connect four Velomitor sensors, 135489-03

Figure 3: Barrier I/O Modules

3500/70M Recip Impulse Velocity Monitor
Datasheet

166766 Rev. T

Copyright 2025 Baker Hughes Company. All rights reserved.

Bently Nevada, a Baker Hughes Company
1631 Bently Parkway South, Minden, Nevada USA 89423
<https://bntechsupport.com>

CONTACT US & SUPPORT

NEED A QUOTE OR TECHNICAL PARTS REPLACEMENT?

Company: [PLC ProTech Ltd.](#)
Website: www.plcprotech.com
Email: sales@plcprotech.com
Phone: +86 180 4631 7198

Our Service Guarantee:

- 100% Brand New Original & Factory Sealed Components
- 12-Month Quality Warranty on All Industrial Parts
- Worldwide Same-Day Fast Dispatch via DHL / FedEx

[SUBMIT ONLINE RFQ \(REQUEST FOR QUOTE\) >>](#)

[About Us](#) · [Contact](#) · [All Products](#)