

# IEPE Accelerometer Series

## Datasheet

Cordant™

124M2609 Rev. H

## Description

This series of Integrated Electronics Piezo-Electric (IEPE) accelerometers are optimized for obtaining high quality vibration signals in harsh industrial environments. Their piezo sensing elements provide exceptional dynamic range, frequency range and linearity, while their integrated amplifiers boost the signal, making them relatively immune to electrical noise.

They require an industry standard constant-current power supply, and provide an output voltage proportional to the acceleration signal. So they can interface to a wide variety of condition monitoring systems.

Within the series are options for 100 or 500 mV/g sensitivity, top-exit or side-exit connector, and several hazardous-area certification levels.

### Features

- Rugged stainless design, corrosion resistant
- Hermetic seal, case isolated
- ESD protection
- Reverse wiring protection
- EMI / RFI shielded
- Hazardous area certifications

### Benefits

- Able to fit in small spaces
- Light weight for walk around programs
- Cross wiring does not harm sensor
- Prevents ground loops in permanent mount applications
- Can be hosed down or submersed with proper connector
- Can be used in applicable certified hazardous areas



## Compliance

- See individual accelerometers for compliance.

## Accelerometers in the Series

Part Number	Cable exit	Sensitivity	Accel range	Frequency Range (3dB)	Haz-area rating
AM3100T2-Z2	Top exit sensor	100 mV/g	80 g	0.4-14,000 Hz	Zone 2 rated
AS3100S2-Z2	Side exit sensor	100 mV/g	80 g	0.5-10,000 Hz	Zone 2 rated
AP3500T2-Z1	Top exit sensor	500 mV/g	10 g	0.2-10,000 Hz	Zone 1 rated
AP3500S2-Z1	Side exit sensor	500 mV/g	10 g	0.2-14,000 Hz	Zone 1 rated
AM3100T2-Z0	Top exit sensor	100 mV/g	80 g	0.4-14,000 Hz	Zone 0 rated
AS3100S2-Z0	Side exit sensor	100 mV/g	80 g	0.7-10,000 Hz	Zone 0 rated
181M6049	Top exit sensor	100 mV/g	60 g	0.5-12,000 Hz	Zone 0 rated

# AM3100T2-Z2

## Specifications

### Dynamic

Sensitivity, $\pm 5\%$ @25°C	100 mV/g
Acceleration range	80 g peak
Amplitude nonlinearity	1%
Frequency response	$\pm 10\%$ : 0.7-9,000 Hz $\pm 3$ dB: 0.4-14,000 Hz
Resonant frequency	30 kHz
Transverse sensitivity, max	$\pm 5\%$ of axial
Temperature response	-55°C : -20% +120°C : +10%

### Electrical

Voltage source	18-30 Vdc
Current regulating diode	2-10 mA
Broadband electrical noise @ 2.5 Hz to 25 kHz	500 $\mu$ g
Spectral electrical noise @ 10 Hz	7 $\mu$ g/ $\sqrt{\text{Hz}}$
Spectral electrical noise @ 100 Hz	4 $\mu$ g/ $\sqrt{\text{Hz}}$
Spectral electrical noise @ 1000 Hz	2 $\mu$ g/ $\sqrt{\text{Hz}}$
Output Impedance, max	100 $\Omega$
Bias output voltage	12 Vdc
Grounding	case isolated, internally shielded

### Environmental

Temperature range	-55°C to 120°C
Vibration limit	500 g peak
Shock limit	5,000 g peak
Electromagnetic sensitivity, equiv g, max	70 $\mu$ g/gauss
Sealing	Hermetic
Base strain sensitivity, max	0.0002 g/ $\mu$ strain

### Physical

Sensing element design	PZT ceramic / shear
Weight	62 grams
Case material	316L Stainless Steel
Mounting	¼-28 UNF tapped hole
Connector	Top exit, 2-pin, MIL-C-5015 style
Recommended cabling	Shielded, twisted pair, no longer than 100 feet

### Connections

Connector Pin	Function
Shell	ground
A	power/signal
B	common



Frequency response and spectral noise values are typical.

## Compliance and Certifications

This device complies with part 15 of the FCC Rules.  
Operation is subject to the following two conditions:

1. This device may not cause harmful interference.
2. This device must accept any interference received, including interference that may cause undesired operation.

## European Community Directives

ATEX Directive 2014/34/EU  
EMC Directive 2014/30/EU  
LV Directive 2014/35/EU  
Reach Directive 1907/2006/EC  
ROHS Directive 2011/65/EU

## Standards

EN 61326-1  
EN 60079-0  
EN 60079-15

## Hazardous Area Approvals

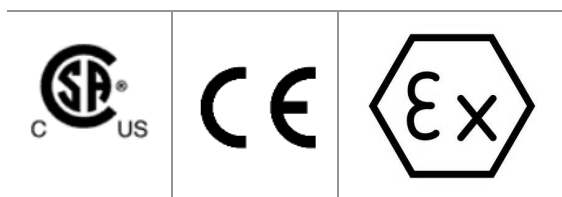

## CSA/NRTL/C

Class I, Div 2, Groups A, B, C, D  
Class I, Zone 2, AEx/Ex nA IIC T4  
Install per drawing 117M2767

## Atex/IECEx

 II 3G Ex nA nC IIC T4 Gc

# AS3100S2-Z2 Specifications

## Dynamic

Sensitivity, $\pm 5\%$ @25°C	100 mV/g
Acceleration range	80 g peak
Amplitude nonlinearity	1%
Frequency response	$\pm 10\%$ : 1.0–5,000 Hz $\pm 3$ dB: 0.5–10,000 Hz
Resonant frequency	22 kHz
Transverse sensitivity, max	$\pm 5\%$ of axial
Temperature response	-55°C: -20% +120°C: +10%

## Electrical

Voltage source	18–30 Vdc
Current regulating diode	2–10 mA
Broadband electrical noise @ 2.5 Hz to 25 kHz	700 $\mu$ g
Spectral electrical noise @ 10 Hz	10 $\mu$ g/ $\sqrt{\text{Hz}}$
Spectral electrical noise @ 100 Hz	5 $\mu$ g/ $\sqrt{\text{Hz}}$
Spectral electrical noise @ 1000 Hz	5 $\mu$ g/ $\sqrt{\text{Hz}}$
Output Impedance, max	100 $\Omega$
Bias output voltage	12 Vdc
Grounding	case isolated, internally shielded

## Environmental

Temperature range	-55°C to 120°C
Vibration limit	500 g peak
Shock limit	5,000 g peak
Electromagnetic sensitivity, equiv g, max	70 $\mu$ g/gauss
Sealing	Hermetic
Base strain sensitivity, max	0.002 g/ $\mu$ strain

## Physical

Sensing element design	PZT ceramic / shear
Weight	145 grams
Case material	316L Stainless Steel
Mounting	1/4-28 UNF tapped hole
Connector	Side exit, 2-pin, MIL-C-5015 style
Recommended cabling	Shielded, twisted pair, no longer than 100 feet

## Connections

Connector Pin	Function
Shell	ground
A	power/signal
B	common



Frequency response and spectral noise values are typical.

## Compliance and Certifications

This device complies with part 15 of the FCC Rules.  
Operation is subject to the following two conditions:

1. This device may not cause harmful interference.
2. This device must accept any interference received, including interference that may cause undesired operation.



## European Community Directives

EMC Directive 2014/30/EU  
LV Directive 2014/35/EU  
Reach Directive 1907/2006/EC  
ROHS Directive 2011/65/EU

## Hazardous Area Approvals

### CSA/NRTL/C

Class I, Div 2, Groups A, B, C, D  
Class I, Zone 2: AEx/Ex nA IIC T4  
Install per drawing 117M2767

# AP3500T2-Z1

## Specifications

### Dynamic

Sensitivity, $\pm 5\%$ @25°C	500 mV/g
Acceleration range	10 g peak
Amplitude nonlinearity	1%
Frequency response	$\pm 5\%$ : 0.7 - 5,000 Hz $\pm 10\%$ : 0.5-9,000 Hz $\pm 3$ dB : 0.2-14,000 Hz
Resonant frequency	30 kHz
Transverse sensitivity, max	$\pm 5\%$ of axial
Temperature response	-20°C: -10% +120°C: +10%

### Electrical

Voltage source	18-30 VDC
Current regulating diode	2-10 mA
Broadband electrical noise @ 2.5 Hz to 25 kHz	250 $\mu$ g
Spectral electrical noise @ 10 Hz	2.5 $\mu$ g/ $\sqrt{\text{Hz}}$
Spectral electrical noise @ 100 Hz	1.5 $\mu$ g/ $\sqrt{\text{Hz}}$
Spectral electrical noise @ 1000 Hz	1.5 $\mu$ g/ $\sqrt{\text{Hz}}$
Output Impedance, max	100 $\Omega$
Bias output voltage	12 VDC

Grounding	case isolated, internally shielded
-----------	------------------------------------

### Environmental

Temperature range	-50°C to 120°C
Vibration limit	500 g peak
Shock limit	5,000 g peak
Electromagnetic sensitivity, equiv g, max	70 $\mu$ g/gauss
Sealing	Hermetic
Base strain sensitivity, max	0.0002 g/ $\mu$ strain

### Physical

Sensing element design	PZT / shear
Weight	90 grams
Case material	316L Stainless Steel
Mounting	1/4-28 UNF tapped hole
Connector	Top exit, 2-pin, MIL-C-5015 style
Recommended cabling	shielded, twisted pair, no longer than 100 feet

### Connections

Connector Pin	Function
Shell	ground
A	power/signal
B	common



Frequency response and spectral noise values are typical.

## Compliance and Certifications

This device complies with part 15 of the FCC Rules. Operation is subject to the following two conditions:

1. This device may not cause harmful interference.
2. This device must accept any interference received, including interference that may cause undesired operation.



## European Community Directives

EMC Directive 2014/30/EU  
LV Directive 2014/35/EU  
Reach Directive 1907/2006/EC  
ROHS Directive 2011/65/EU

## Hazardous Area Approvals

### CSA/NRTL/C

Class I, Div 1, Groups A, B, C, D  
Class II, Div 1, Groups E, F, G  
Class III, Div 1  
Class I, Zone 0: AEx/Ex ia IIC T4  
Install per drawing 117M4393

# AP3500S2-Z1 Specifications

## Dynamic

Sensitivity, $\pm 5\%$ @25°C	500 mV/g
Acceleration range	10 g peak
Amplitude nonlinearity	1%
Frequency response	$\pm 10\%$ : 0.5–5,000 Hz $\pm 3$ dB : 0.2–10,000 Hz
Resonant frequency	22 kHz
Transverse sensitivity, max	$\pm 5\%$ of axial
Temperature response	-20°C: -10% +120°C: +10%

## Electrical

Voltage source	18–28 VDC
Current regulating diode	2–10 mA
Broadband electrical noise @ 2.5 Hz to 25 kHz	250 $\mu$ g
Spectral electrical noise @ 10 Hz	2.5 $\mu$ g/ $\sqrt{\text{Hz}}$
Spectral electrical noise @ 100 Hz	1.5 $\mu$ g/ $\sqrt{\text{Hz}}$
Spectral electrical noise @ 1000 Hz	1.5 $\mu$ g/ $\sqrt{\text{Hz}}$
Output Impedance, max	100 $\Omega$
Bias output voltage	12 VDC
Grounding	case isolated, internally shielded

## Environmental

Temperature range	-50°C to 120°C
Vibration limit	500 g peak
Shock limit	5,000 g peak
Electromagnetic sensitivity, equiv g, max	70 $\mu$ g/gauss
Sealing	Hermetic
Base strain sensitivity, max	0.0002 g/ $\mu$ strain

## Physical

Sensing element design	PZT / shear
Weight	145 grams
Case material	316L Stainless Steel
Mounting	1/4-28 captive hex head screw 0.046" diameter safety wire hole
Connector	Side exit, 2-pin, MIL-C-5015 style
Recommended cabling	shielded, twisted pair, no longer than 100 feet

## Connections

Connector Pin	Function
Shell	ground
A	power/signal
B	common



Frequency response and spectral noise values are typical.

## Compliance and Certifications

This device complies with part 15 of the FCC Rules.  
Operation is subject to the following two conditions:

1. This device may not cause harmful interference.
2. This device must accept any interference received, including interference that may cause undesired operation.



## European Community Directives

EMC Directive 2014/30/EU  
LV Directive 2014/35/EU  
Reach Directive 1907/2006/EC  
ROHS Directive 2011/65/EU

## Hazardous Area Approvals

### CSA/NRTL/C

Class I, Div 1, Groups A, B, C, D  
Class II, Div 1, Groups E, F, G  
Class III, Div 1  
Class I, Zone 0: AEx/Ex ia IIC T4  
Install per drawing 117M4393

# AM3100T2-Z0

## Specifications

### Dynamic

Sensitivity, $\pm 5\%$ @25°C	100 mV/g
Acceleration range	80 g peak
Amplitude nonlinearity	1%
Frequency response	$\pm 10\%$ : 0.7–9,000 Hz $\pm 3$ dB : 0.4–14,000 Hz
Resonant frequency	30 kHz
Transverse sensitivity, max	$\pm 5\%$ of axial
Temperature response	-55°C: -20% +120°C: +10%

### Electrical

Voltage source	18–30 Vdc
Current regulating diode	2–10 mA
Broadband electrical noise @ 2.5 Hz to 25 kHz	500 $\mu$ g
Spectral electrical noise @ 10 Hz	7 $\mu$ g/ $\sqrt{\text{Hz}}$
Spectral electrical noise @ 100 Hz	4 $\mu$ g/ $\sqrt{\text{Hz}}$
Spectral electrical noise @ 1000 Hz	2 $\mu$ g/ $\sqrt{\text{Hz}}$
Output Impedance, max	100 $\Omega$
Bias output voltage	12 Vdc
Grounding	Case isolated, internally shielded

### Environmental

Temperature range	-50°C to 120°C
Vibration limit	500 g peak
Shock limit	5,000 g peak
Electromagnetic sensitivity, equiv g, max	70 $\mu$ g/gauss
Sealing	Hermetic
Base strain sensitivity, max	0.0002 g/ $\mu$ strain

### Physical

Sensing element design	PZT ceramic / shear
Weight	62 grams
Case material	316L Stainless Steel
Mounting	1/4-28 UNF tapped hole
Connector	Top exit, 2-pin, MIL-C-5015 style
Recommended cabling	Shielded, twisted pair, no longer than 100 feet

### Connections

Connector Pin	Function
Shell	ground
A	power/signal
B	common



Frequency response and spectral noise values are typical.

## Compliance and Certifications

This device complies with part 15 of the FCC Rules.  
Operation is subject to the following two conditions:

1. This device may not cause harmful interference.
2. This device must accept any interference received, including interference that may cause undesired operation.

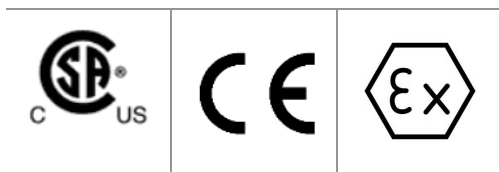

## European Community Directives

ATEX Directive 2014/34/EU  
EMC Directive 2014/30/EU  
LV Directive 2014/35/EU  
Reach Directive 1907/2006/EC  
ROHS Directive 2011/65/EU

## Standards

EN 61326-1  
EN 60079-0  
EN 60079-11

## Hazardous Area Approvals

### CSA/NRTL/C

Class I, Div 1, Groups A, B, C, D  
Class II, Div 1, Groups E, F, G  
Class III, Div 1  
Class I, Zone 0, Ex ia IIC T4  
Class I, Zone 0, AEx ia IIC T4  
Install per drawing 117M4394

### ATEX/IECEx

II 1 G  
Ex ia IIC T4 Ga

# AS3100S2-Z0

## Specifications

### Dynamic

Sensitivity, $\pm 5\%$ @25°C	100 mV/g
Acceleration range	80 g peak
Amplitude nonlinearity	1%
Frequency response	$\pm 10\%$ : 1.0-5,000 Hz $\pm 3$ dB : 0.7-10,000 Hz
Resonant frequency	22 kHz
Transverse sensitivity, max	$\pm 5\%$ of axial
Temperature response	-55°C: -8% +120°C: +10%

### Electrical

Voltage source	18-30 Vdc
Current regulating diode	2-10 mA
Broadband electrical noise @ 2.5 Hz to 25 kHz	700 $\mu$ g
Spectral electrical noise @ 10 Hz	10 $\mu$ g/ $\sqrt{\text{Hz}}$
Spectral electrical noise @ 100 Hz	5 $\mu$ g/ $\sqrt{\text{Hz}}$
Spectral electrical noise @ 1000 Hz	5 $\mu$ g/ $\sqrt{\text{Hz}}$
Output Impedance, max	100 $\Omega$
Bias output voltage	12 Vdc
Grounding	Case isolated, internally shielded

### Environmental

Temperature range	-50°C to 120°C
Vibration limit	500 g peak
Shock limit	5,000 g peak
Electromagnetic sensitivity, equiv g, max	70 $\mu$ g/gauss
Sealing	Hermetic
Base strain sensitivity, max	0.002 g/ $\mu$ strain

### Physical

Sensing element design	PZT ceramic / shear
Weight	145 grams
Case material	316L Stainless Steel
Mounting	1/4-28 captive hex head ascrew
Connector	Side exit, 2-pin, MIL-C-5015 style
Recommended cabling	Shielded, twisted pair, no longer than 100 feet

### Connections

Connector Pin	Function
Shell	ground
A	power/signal
B	common



Frequency response and spectral noise values are typical.

## Compliance and Certifications

This device complies with part 15 of the FCC Rules.  
Operation is subject to the following two conditions:

1. This device may not cause harmful interference.
2. This device must accept any interference received, including interference that may cause undesired operation.

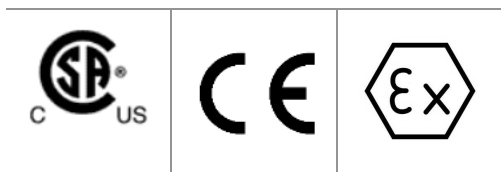

## European Community Directives

ATEX Directive 2014/34/EU  
EMC Directive 2014/30/EU  
LV Directive 2014/35/EU  
Reach Directive 1907/2006/EC  
ROHS Directive 2011/65/EU

## Standards

EN 61326-1  
EN 60079-0  
EN 60079-11

## Hazardous Area Approvals

### CSA/NRTL/C

Class I, Div 1, Groups A, B, C, D  
Class II, Div 1, Groups E, F, G  
Class III, Div 1  
Class I, Zone 0, Ex ia IIC T4  
Class I, Zone 0, AEx ia IIC T4  
Install per drawing 117M4394

### ATEX/IECEx

II 1 G  
Ex ia IIC T4 Ga

# 181M6049 Dual Output Sensor Specifications

## Dynamic

Sensitivity, $\pm 5\%$ @25°C	100 mV/g
Acceleration range	60 g peak
Amplitude nonlinearity	1%
Frequency response	$\pm 5\%$ : 3-5,000 Hz $\pm 10\%$ : 1-7,000 Hz $\pm 3$ dB: 0.5-12,000 Hz
Resonant frequency	30 kHz
Transverse sensitivity, max	$\pm 5\%$ of axial
Temperature response	-50°C : -10% +120°C : +10%
Output sensitivity of the temperature sensor	10 mV/°C
Measurement range of the temperature sensor	2° to 120°C

## Electrical

Voltage source	18-28 Vdc
Current regulating diode	2-10 mA
Broadband electrical noise @ 2.5 Hz to 25 kHz	700 $\mu$ g
Spectral electrical noise @ 10 Hz	10 $\mu$ g/ $\sqrt{\text{Hz}}$
Spectral electrical noise @ 100 Hz	5 $\mu$ g/ $\sqrt{\text{Hz}}$

Spectral electrical noise @ 1000 Hz	5 $\mu$ g/ $\sqrt{\text{Hz}}$
Output Impedance, max	100 $\Omega$
Bias output voltage	12 Vdc
Grounding	Case isolated, internally shielded

## Environmental

Temperature range	-50°C to +120°C
Vibration limit	500 g peak
Shock limit	5,000 g peak
Electromagnetic sensitivity, equiv g, max	70 $\mu$ g/gauss
Sealing	Hermetic
Base strain sensitivity, max	0.0002 g/ $\mu$ strain

## Physical

Sensing element design	PZT ceramic / shear
Weight	90 grams
Case material	316L Stainless Steel
Mounting	¼-28 UNF tapped hole
Connector	Output: 3 pin, MIL-C-5015 style
Recommended cabling	16925-XX: Without Armor 16710-XX: With Armor

## Connections

Connector Pin	Function
Shell	ground/case
A	accelerometer power/signal
B	accelerometer and temp sensor common
C	temp sensor signal



Frequency response and spectral noise values are typical.

## Compliance and Certifications

This device complies with part 15 of the FCC Rules. Operation is subject to the following two conditions:

1. This device may not cause harmful interference.
2. This device must accept any interference received, including interference that may cause undesired operation.



## European Community Directives

ATEX Directive 2014/34/EU  
 EMC Directive 2014/30/EU  
 LV Directive 2014/35/EU  
 Reach Directive 1907/2006/EC  
 ROHS Directive 2011/65/EU

## Standards

EN 61326-1  
 EN 60079-0  
 EN 60079-11

## Hazardous Area Approvals

### CSA/NRTL/C

Class I, Div 1, Groups A, B, C, D  
 Class II, Div 1, Groups E, F, G  
 Class III, Div 1  
 Class I, Zone 0, Ex ia IIC T4  
 Class I, Zone 0, AEx ia IIC T4  
 Install per drawing 12880

### ATEX/IECEx

II 1 G  
 Ex ia IIC T4 Ga

# Ordering Information

Part Number	Cable exit	Sensitivity	Accel range	Frequency Range (3dB)	Haz-area rating
AM3100T2-Z2	Top exit sensor	100 mV/g	80 g	0.4-14,000 Hz	Zone 2 rated
AS3100S2-Z2	Side exit sensor	100 mV/g	80 g	0.5-10,000 Hz	Zone 2 rated
AP3500T2-Z1	Top exit sensor	500 mV/g	10 g	0.2-10,000 Hz	Zone 1 rated
AP3500S2-Z1	Side exit sensor	500 mV/g	10 g	0.2-14,000 Hz	Zone 1 rated
AM3100T2-Z0	Top exit sensor	100 mV/g	80 g	0.4-14,000 Hz	Zone 0 rated
AS3100S2-Z0	Side exit sensor	100 mV/g	80 g	0.7-10,000 Hz	Zone 0 rated
181M6049	Top exit sensor	100 mV/g	60 g	0.5-12,000 Hz	Zone 0 rated

## Accessories supplied:

- ¼-28 to ¼-28 mounting stud
- Calibration Data (AM3100T2-Z0 and AM3100T2-Z2)

## Mounting Studs

Dimensional diagrams of all available mounting studs are shown in [Mounting Stud Dimensional Drawings on page 24](#).

164373	¼-28 Mounting Stud
164372	¼-28 to M6x1 Mounting Stud
167559	¼-28 to M8X1.25 Mounting Stud (Beryllium Copper )
287844	¼-28 to M8X1.25 Mounting Stud (Stainless Steel 303)

## Adhesive Mounting Kits

Adhesive studs are sold in kits containing two threaded studs and two mounting pads. Also in the kit is a packet of acrylic adhesive and materials to mix its two components. A scouring pad and alcohol wipe are provided for preparing the mounting surface.

Temperature Range	-67°F to +250 °F (-55°C to 121 °C)
Cure Time	24 hours

## Magnetic Base Kit

The magnetic base has a pull of 35 lbf and it is suitable for placement on both curved surfaces and flat surfaces. The magnet comes supplied with a ¼-28 mounting stud. A dimensional diagram of the magnetic base is shown in [Magnetic Base Dimensional Drawing on page 24](#).

286244	Magnetic Base w/ Mounting Stud
--------	--------------------------------

## Cables

The standard cables are 22 AWG 2-conductor twisted shielded pairs with 2-socket moisture-resistant female connector at one end, terminal lugs at the other end. Cable length is optional and comes in increments of 1 ft between the stated maximum and minimum lengths.

### Custom Cable Part Numbers

You can order custom cable lengths in increments of 1.0 ft (305 mm) at additional cost. Some cables have a minimum and maximum length.



Use 'NN' in these part numbers to specify the length (in feet) of the cable you want to order.

Part Number	Description
9571-NN	Two-conductor twisted, shielded 22 AWG cable with two-socket moisture-resistant female connector at one end, terminal lugs at the other end. Min. length: 2.0 ft (0.6 m) Max. length: 99 ft (30 m)
84661-NN	Two-conductor twisted, shielded 22 AWG armored cable with two-socket moisture-resistant female connector at one end, terminal lugs at the other end. Min. length: 3.0 ft (0.9 m) Max. length: 96 ft (29 m)
89477-NN	Two-conductor 18 AWG twisted, shielded cable with right angle two-socket plug at one end, terminal lugs at the other end. Min. length: 2.0 ft (0.6 m) Max. length: 99 ft (30 m)
125065-NN	Two-conductor 18 AWG twisted, shielded cable with two-socket plug and fluorosilicone elastomer boot at one end, terminal lugs at the other. Min. length: 2.0 ft (0.6 m) Max. length: 99 ft (30 m)

# Graphs and Figures

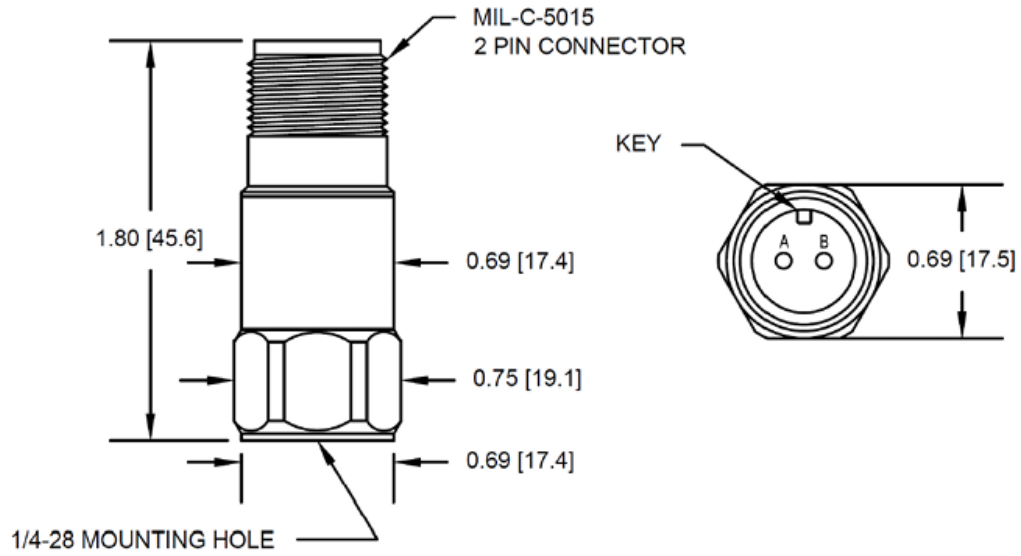

**Figure 1: AM3100T2-Z2 & AM3100T2-Z0 dimensions**

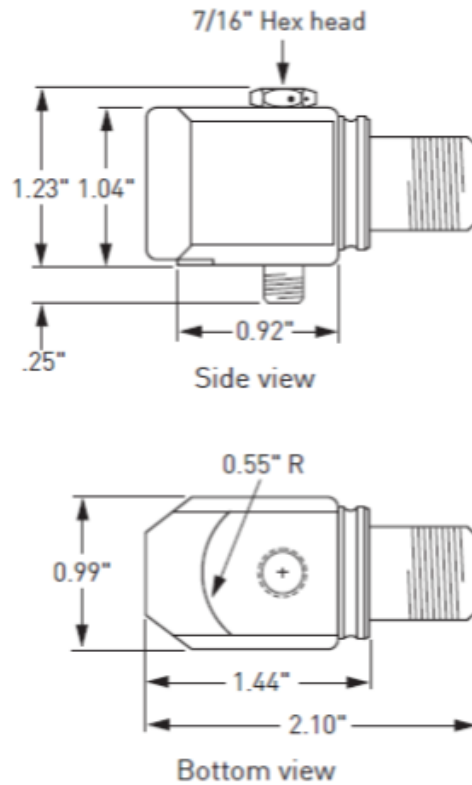

**Figure 2: AS3100S2-Z2 & AS3100S2-Z0 Dimensions**

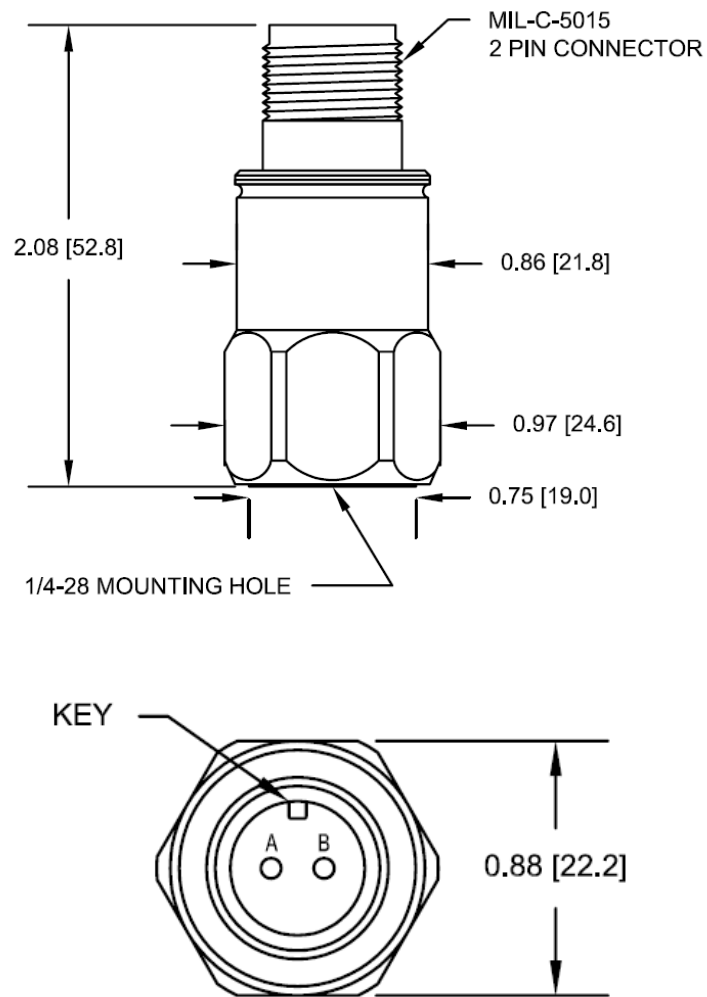

**Figure 3: AP3500T2-Z1 dimensions**

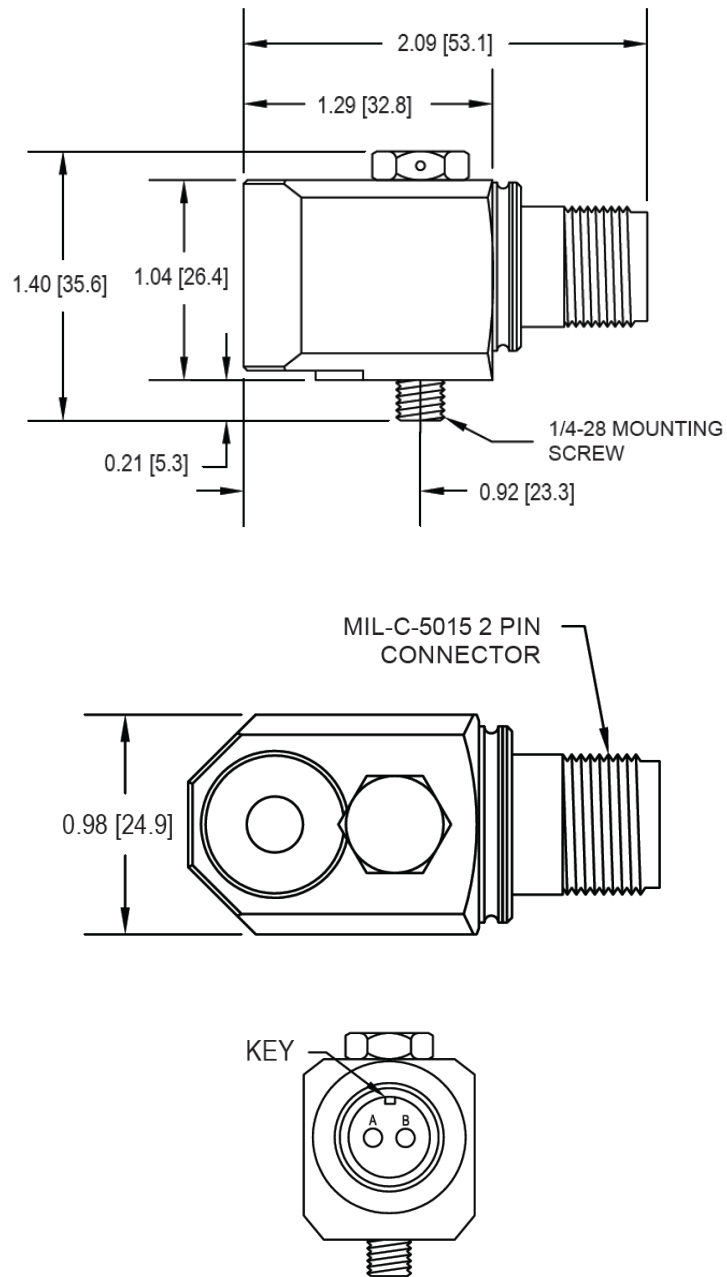

**Figure 4: AP3500S2-Z1 dimensions**

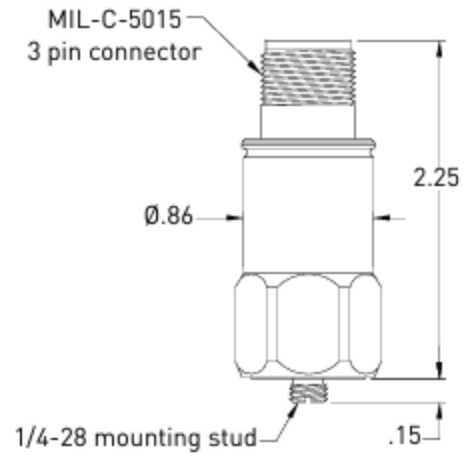

**Figure 5: 181M6049 dimensions**

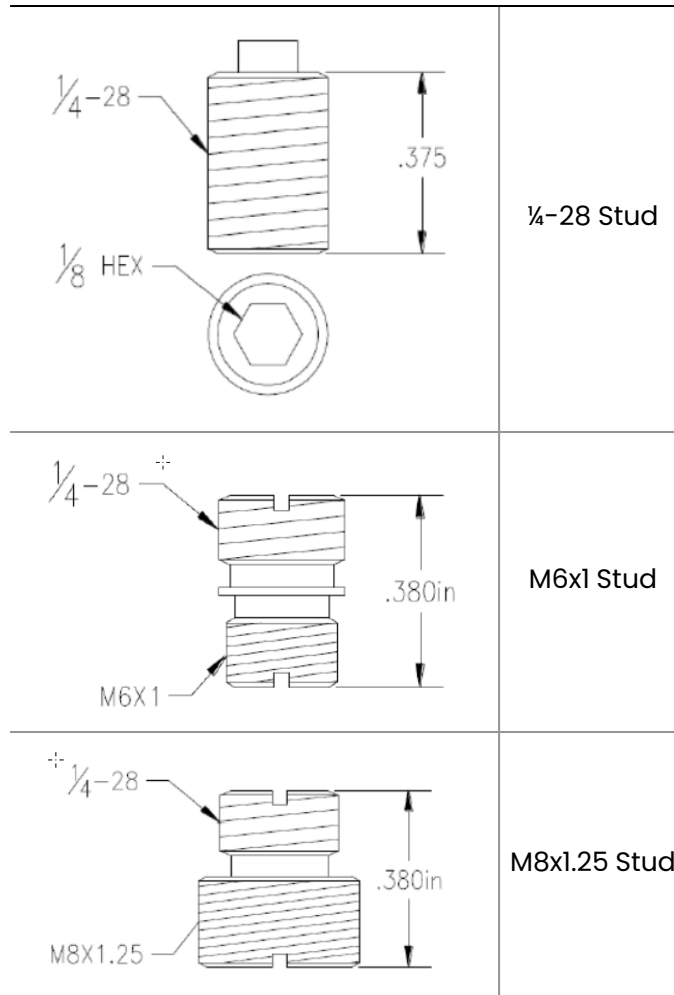

**Figure 6: Mounting Stud Dimensional Drawings**

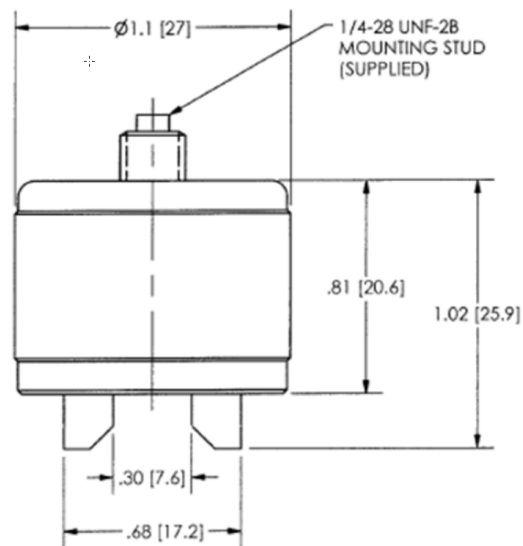

**Figure 7: Magnetic Base Dimensional Drawing**

Copyright 2025 Baker Hughes Company. All rights reserved.

Bently Nevada, a Baker Hughes Company  
1631 Bently Parkway South, Minden, Nevada USA 89423  
<https://bntechsupport.com>