

# 3500/40M Proximator Monitor

## Datasheet

**Cordant™**

141535 Rev. R

### Description

The Bently Nevada™ 3500/40M Proximator Monitor is a four-channel monitor that accepts input from Bently Nevada proximity transducers, conditions the signal to provide various vibration and position measurements, and compares the conditioned signals with user-programmable alarms. The user can program each channel of the 3500/40M with the 3500 Rack Configuration Software to perform any of the following functions:

- Radial vibration
- Thrust position
- Eccentricity
- Differential expansion
- REBAM

The primary purpose of the 3500/40M Proximator Monitor is to provide the following:

- Machinery protection by continuously comparing monitored parameters against configured alarm setpoints to drive alarms
- Essential machine information for both operations and maintenance personnel

Each channel, depending on configuration, typically conditions its input signal to generate various parameters called **static values**. You can configure **alert setpoints** for each active static value and **danger setpoints** for any two of the active static values.



You program the monitor channels in pairs. The monitor channels can perform up to 2 of these functions at a time. Channels 1 and 2 can perform one function, while channels 3 and 4 perform another (or the same) function.



## Specifications

### Inputs

Signal	Accepts from 1 to 4 proximity transducer signals
Power consumption	7.7 Watts, typical
Input Impedance	
Standard I/O	10 kΩ (Proximator and acceleration inputs)

### Sensitivity

Radial Vibration	3.94 mV/μm (100 mV/mil) or 7.87 mV/μm (200 mV/mil)
Thrust	3.94 mV/μm (100 mV/mil) or 7.87 mV/μm (200 mV/mil)
Eccentricity	3.94 mV/μm (100 mV/mil) or 7.87 mV/μm (200 mV/mil)
Differential Expansion	0.394 mV/μm (10 mV/mil) or 0.787 mV/μm (20 mV/mil)
REBAM	40 mV/μm (1000 mV/mil) or 80 mV/μm (2000 mV/mil)

### Outputs

Front Panel LEDs	
OK LED	Indicates when the 3500/40M SIL Proximator is operating properly.
TX/RX LED	Indicates when the 3500/40M SIL Proximator is communicating with other modules in the 3500 rack.
Bypass LED	Indicates when the 3500/40M SIL Proximator is in Bypass Mode.

Front Panel LEDs	
Buffered Transducer Outputs	The front of each monitor has one coaxial connector for each channel. Each connector is short-circuit protected.
Output Impedance	550 Ω
Transducer Power Supply	-24 Vdc

### Signal Conditioning



Specified at +25°C (+77°F) unless otherwise noted.

### Radial Vibration

Frequency Response	
Direct filter	User-programmable Single-pole 4 Hz to 4000 Hz or 1 Hz to 600 Hz
Gap filter	-3 dB at 0.09 Hz
Not 1X filter	60 cpm to 15.8 times running speed Constant Q notch filter Minimum rejection in stopband of -34.9 dB
Smax	0.125 to 15.8 times running speed
1X and 2X vector filter	Constant Q Filter Minimum rejection in stopband of -57.7 dB



1X and 2X Vector, Not 1X, and Smax parameters are valid for machine speeds of 60 cpm to 60,000 cpm.

3500/40M Proximito Monitor  
 Datasheet

141535 Rev. R

**Accuracy**

Direct and Gap	Exclusive of filtering Within ±0.33% of full-scale typical ±1% maximum
1X and 2X	Within ±0.33% of full-scale typical ±1% maximum
Smax	Within ±5% maximum
Not 1X	±3% for machine speeds less than 30,000 cpm ±8.5% for machine speeds greater than 30,000 cpm

**Thrust and Differential Expansion**

Accuracy	Within ±0.33% of full-scale typical ±1% maximum
----------	--

**Frequency Response**

Direct filter	-3 dB at 1.2 Hz
Gap filter	-3 dB at 0.41 Hz

**Eccentricity**

Accuracy	Within ±0.33% of full-scale typical ±1% maximum
----------	--

**Frequency Response**

Direct filter	-3 dB at 15.6 Hz
Gap filter	-3 dB at 0.41 Hz

**REBAM**

**Frequency Response**

Spike	User-programmable from 0.152 to 8678 Hz
-------	---

**Frequency Response**

Element	User-programmable for BPFO ranging from 0.139 to 3836 Hz High-pass corner is 0.8x BPFO. Low-pass corner is 2.2x BPFO.
Rotor	User programmable from 0.108 to 2221 Hz
Direct	Programmable from 3.906 to 14.2 Hz Selection is determined by Spike and Rotor filters.
Gap	Programmable from 0.002 to 1.0 Hz Selection is determined by the Rotor filter.
1X vector filter	The range of shaft speeds for which the value is valid depends on the nominal shaft speed for which the channel is configured.

**Table 1: Relationship Between Nominal Shaft Speed and the Valid Speed Range**

Nominal Shaft Speed (Hz)	Valid Speed Range (Hz)
10 to <126	0.071 to 160
126 to <252	0.133 to 330
252 to <504	0.25 to 660
504 to 584	0.50 to 750



If a multi-event gear or speed wheel generates the speed input, the upper limitation of the resultant input signal is approximately 20 KHz.

3500/40M Proximito Monitor  
 Datasheet

141535 Rev. R

Filter Quality	
Spike high-pass	6-pole Elliptic (155 dB per decade, minimum) Corner frequency is -0.1 dB.
Element bandpass	8-pole Butterworth (155 dB per decade minimum) Corner frequency is -3 dB.
Rotor low-pass	6-pole Elliptic (155 dB per decade, minimum) Corner frequency is -0.1 dB.
Rotor, direct high-pass	1-pole Butterworth (18 dB per decade, minimum) Corner frequency is -3 dB.
Spike, direct low-pass	Corner is -0.3 dB maximum.
Gap low-pass	1-pole Butterworth (18 dB per decade, minimum) Corner frequency is -3 dB.
1X amplitude	Constant Q of 16.67 Stopband frequencies are 0.91 and 1.09 times the running speed. Stopband attenuation is -51 dB minimum.

Accuracy	
Phase	3 degrees error, maximum
Channels enabled	Certain configurations allow the user to enable only one channel of a channel pair.

Filter Tracking / Stepping (Requires a valid speed signal)	
Initial condition	Nominal filter set used
Switch from nominal to lower filter set	Current shaft speed $\leq 0.9 \times$ (nominal shaft speed)
Switch from lower to nominal filter set	Current shaft speed $\geq 0.95 \times$ (nominal shaft speed)
Switch from nominal to higher filter set	Current shaft speed $\geq 1.1 \times$ (nominal shaft speed)
Switch from higher to nominal filter set	Current shaft speed $\leq 1.05 \times$ (Nominal Shaft Speed)
Shaft speed error condition	Nominal filter set used

Accuracy	
Amplitude	Within $\pm 0.33\%$ of full scale typical  $\pm 1\%$ maximum when input signal is at the center frequency of the measured value's passband

3500/40M Proximitor Monitor  
 Datasheet

141535 Rev. R

## Environmental Limits

Operating Temperature	When used with Internal/External Termination I/O Module: -30°C to +65°C (-22°F to +150°F)  When used with Internal Barrier I/O Module (Internal Termination): 0°C to +65°C (32°F to +150°F)
Storage Temperature	-40°C to +85°C (-40°F to +185°F).
Humidity	95%, noncondensing

## Physical

Monitor Module (Main Board)	
Dimensions (Height x Width x Depth)	241.3 mm x 24.4 mm x 241.8 mm (9.50 in x 0.96 in x 9.52 in)
Weight	0.91 kg (2.0 lb)
I/O Modules (non-barrier)	
Dimensions (Height x Width x Depth)	241.3 mm x 24.4 mm x 99.1 mm (9.50 in x 0.96 in x 3.90 in)
Weight	0.20 kg (0.44 lb)
I/O Modules (barrier)	
Dimensions (Height x Width x Depth)	241.3 mm x 24.4 mm x 163.1 mm (9.50 in x 0.96 in x 6.42 in)
Weight	0.46 kg (1.01 lb)

## Rack Space Requirements

Monitor	1 full-height front slot
I/O Modules	1 full-height rear slot

## Barrier Parameters

The following parameters apply to CSA-NRTL/C and ATEX / IECEx approvals.

Proximitor Barrier	
Circuit Parameters	V <sub>max</sub> (PWR) = 26.25V (SIG) = 13.65 V  I <sub>max</sub> (PWR) = 110.48 mA (SIG) = 2.74mA  R <sub>min</sub> (PWR) = 237.6 Ω (SIG) = 4985 Ω
Channel Parameters (entity)	V <sub>max</sub> = 27.45 V I <sub>max</sub> = 113.24 mA R <sub>min</sub> (PWR) = 237.6 Ω (SIG) = 4985 Ω

## Alarms

Alarm Setpoints	Use Rack Configuration Software to set alert levels for each value measured by the monitor and Danger setpoints for any two of the values measured by the monitor.  Alarms are adjustable from 0 to 100% of full-scale for each measured value. However, when the full-scale range exceeds the range of the transducer, the range of the transducer will limit the setpoint.
Accuracy of alarm setpoints	Within 0.13% of the desired value

## Alarm Time Delays



You can program alarm delays using **Rack Configuration Software.**

3500/40M Proximito Monitor  
 Datasheet

141535 Rev. R

Radial vibration, thrust, differential expansion and eccentricity	
Alert	From one to 60 seconds in one second intervals
Danger	0.1 seconds or from one to 60 seconds in 0.5 second intervals
REBAM	
Alert	From the calculated minimum value to 400 seconds in one second intervals
Danger	From the calculated minimum value to 400 seconds in 0.5 second intervals

### Static Values

Static values are measurements used to monitor the machine. The 3500/40M Proximito Monitor returns the following static values:

Radial Vibration	Direct, Gap, 1X Amplitude, 1X Phase Lag, 2X Amplitude, 2X Phase Lag, Not 1X Amplitude and Smax Amplitude
Thrust Position	Direct, Gap
Differential Expansion	Direct, Gap
Eccentricity	Peak-to-peak, Gap, Direct Minimum, Direct Maximum
REBAM	Spike, Element, Rotor, Direct, Gap, 1X Amplitude, 1X Phase Lag

3500/40M Proximity Monitor  
Datasheet

141535 Rev. R

## Compliance and Certifications

### FCC

This device complies with part 15 of the FCC Rules. Operation is subject to the following two conditions:

- This device may not cause harmful interference.
- This device must accept any interference received, including interference that may cause undesired operation.

### EMC

European Community Directive:

EMC Directive 2014/30/EU

Standards:

EN 61000-6-2 Immunity for  
Industrial Environments  
EN 61000-6-4 Emissions for  
Industrial Environments

### Electrical Safety

European Community Directive:

LV Directive 2014/35/EU

Standards:

EN 61010-1

### RoHS

European Community Directive:

RoHS Directive 2011/65/EU

### China RoHS

Cables associated with the product(s) mentioned in this datasheet have an EFUP designation of 15 years, in accordance with SJ/T 11364-2024.



### Maritime

ABS-Marine and Offshore Applications

DNV GL Rules for Classification – Ships,  
Offshore Units, and High Speed and Light  
Craft

3500/40M Proximito Monitor  
 Datasheet

141535 Rev. R

## Hazardous Area Approvals



For the detailed listing of country and product-specific approvals, refer to the [Approvals Quick Reference Guide \(108M1756\)](#).

For additional technical documentation, please log in to [bntechsupport.com](http://bntechsupport.com) and access the Bently Nevada Media Library.

When used with I/O module ordering options with internal barriers	 <p>II 3(1) G                  Ex nA nC ic [ia Ga] IIC T4 Gc;                  Ex ec nC ic [ia Ga] IIC T4 Gc;                  T4 @ Ta= -20°C to +65°C (-4°F to +149°F)                  When installed per drawing 138547.</p>
---	--

## cNRTLus

When used with I/O module ordering options without internal barriers	<p>Class I, Zone 2: AEx/Ex nA nC ic IIC T4 Gc;                  Class I, Zone 2: AEx/Ex ec nC ic IIC T4 Gc;                  Class I, Division 2, Groups A, B, C, and D;</p> <p>T4 @ Ta= -20°C to +65°C (-4°F to +149°F)                  When installed per drawing 149243 or 149244.</p>
When used with I/O module ordering options with internal barriers	<p>Class I, Zone 2: AEx/Ex nA nC ic [ia Ga] IIC T4 Gc;                  Class I, Zone 2: AEx/Ex ec nC ic [ia Ga] IIC T4 Gc;                  Class I, Division 2, Groups A, B, C, and D (W/ IS Output for Division 1)</p> <p>T4 @ Ta= -20°C to +65°C (-4°F to +149°F)                  When installed per drawing 138547.</p>

## ATEX/IECEx

When used with I/O module ordering options without internal barriers	 <p>II 3 G                  Ex nA nC ic IIC T4 Gc;                  Ex ec nC ic IIC T4 Gc;</p> <p>T4 @ Ta= -20°C to +65°C (-4°F to +149°F)                  When installed per drawing 149243 or 149244.</p>
--	---

# Ordering Considerations

## General

The 3500/40M Module requires the following (or later) firmware, and software revisions:

- 3500/01 Software – Version 2.50
- 3500/02 Software – Version 2.20
- 3500/03 Software – Version 1.21

When ordering I/O Modules with External Terminations the External Termination Blocks and Cable must be ordered separately for each I/O Module.

External Termination Blocks cannot be used with Internal Termination I/O Modules.

## Internal Barrier I/O Modules

Consult the 3500 Internal Barrier specification sheet (document 141495) if the Internal Barrier Option is selected.

## REBAM

The REBAM channel type requires the following (or later) firmware, and software revisions:

- 3500/40M Module Firmware – Revision 2.1
- 3500/01 Software – Version 3.30
- 3500/02 Software – Version 2.40
- 3500/03 Software – Version 1.40
- DM2000 Software–Version 3.40.

Requires the M version of the 3500 Proximator Monitor.

# Ordering Information



For the detailed listing of country and product-specific approvals, refer to the [Approvals Quick Reference Guide](#)



(108M1756).

For additional technical documentation, please log in to [bntechsupport.com](http://bntechsupport.com) and access the Bently Nevada Media Library.

## Proximator Monitor 3500/40M-AA-BB

### A: I/O Module Type

<b>01</b>	Proximator I/O Module with Internal Termination
<b>02</b>	Proximator I/O Module with External Terminations
<b>03</b>	Proximator I/O Module with Internal Barriers and Internal Terminations

### B: Hazardous Area Approval Option

<b>00</b>	None
<b>01</b>	cNRTLus (Class 1, Division 2)
<b>02</b>	ATEX / IECEx / CSA (Class 1, Zone 2)



Agency Approval Option B-02 is only available with Ordering Option A-03

## External Termination Blocks

125808-01	Proximator ET Block Euro Style Connectors
128015-01	Proximator ET Block Terminal Strip Connectors

## Cables

### 3500 Transducer XDCR signal to External Termination (ET) Block Cable 129525-AAAA-BB

#### A: I/O Cable Length

<b>0005</b>	5 feet (1.5 meters)
-------------	---------------------

## 3500/40M Proximitor Monitor

## Datasheet

141535 Rev. R

<b>0007</b>	7 feet (2.1 meters)
<b>0010</b>	10 feet (3.0 meters)
<b>0025</b>	25 feet (7.6 meters)
<b>0050</b>	50 feet (15.2 meters)
<b>0100</b>	100 feet (30.5 meters)

**B: Assembly Instructions**

<b>01</b>	Not assembled
<b>02</b>	Assembled

**Spares**

176449-01	3500/40M Proximitor Monitor
125680-01	Proximitor I/O Module with Internal Terminations
126615-01	Proximitor I/O Module with External Terminations
135489-04	Proximitor I/O Module with Internal Barriers and Internal Terminations
143488	3500/40M Monitor User Guide
00580434	Internal I/O Module connector header, Euro style, 8-pin
00502133	Internal I/O Module connector header, Euro style, 12-pin
166M4363	Connector header, push-in-spring type (alternative for PN 00580441)
166M2389	Connector header, push-in-spring type (alternative for PN 00580434)

## Graphs and Figures

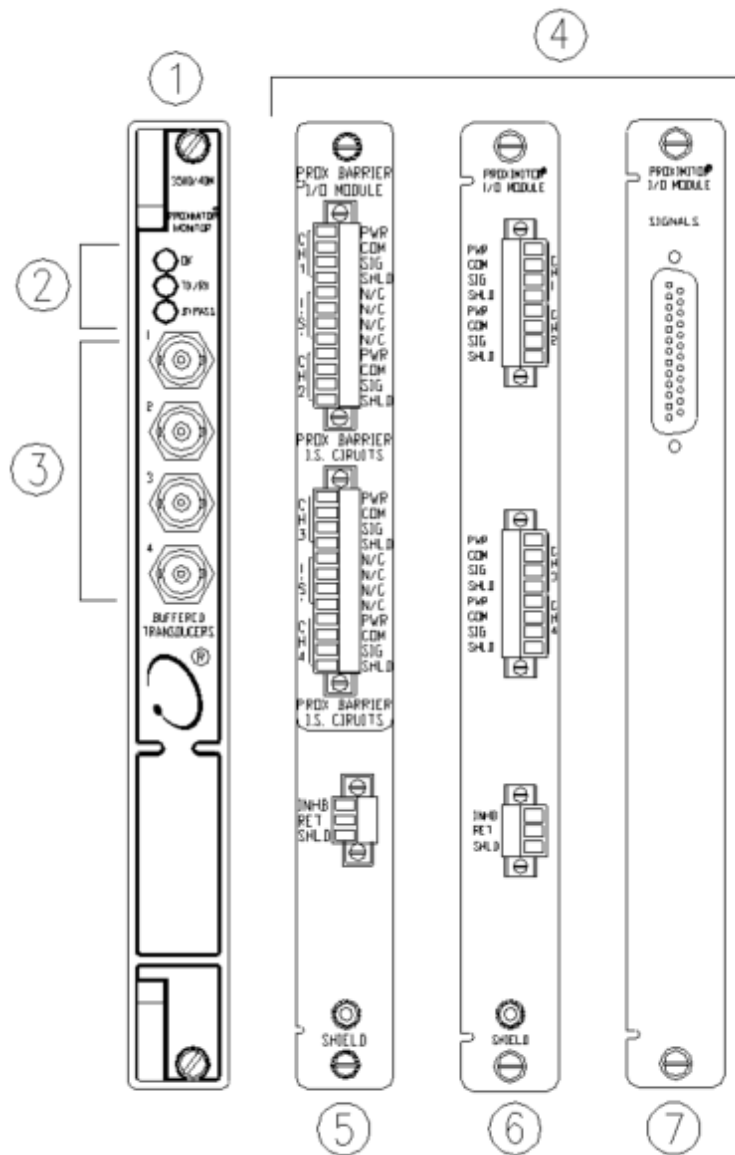

1. Main Module Front View
2. Status LEDs
3. Buffered Transducer Outputs
4. I/O modules
5. Barrier I/O module, Internal Termination
6. I/O Module, Internal Termination
7. I/O Module, External Termination

**Figure 1: Assorted 3500/40M Proximito Monitor Views**

3500/40M Proximito Monitor  
Datasheet

141535 Rev. R

---

Copyright 2025 Baker Hughes Company. All rights reserved.

Bently Nevada, a Baker Hughes Company  
1631 Bently Parkway South, Minden, Nevada USA 89423  
<https://bntechsupport.com>

# CONTACT US & SUPPORT

NEED A QUOTE OR TECHNICAL PARTS REPLACEMENT?

**Company:** [PLC ProTech Ltd.](#)  
**Website:** [www.plcprotech.com](http://www.plcprotech.com)  
**Email:** [sales@plcprotech.com](mailto:sales@plcprotech.com)  
**Phone:** +86 180 4631 7198

## Our Service Guarantee:

- 100% Brand New Original & Factory Sealed Components
- 12-Month Quality Warranty on All Industrial Parts
- Worldwide Same-Day Fast Dispatch via DHL / FedEx

[SUBMIT ONLINE RFQ \(REQUEST FOR QUOTE\) >>](#)

[About Us](#) · [Contact](#) · [All Products](#)