

HIMatrix

Safety-Related Controller

F35 Manual



HIMA Paul Hildebrandt GmbH + Co KG
Industrial Automation

All HIMA products mentioned in this manual are protected by the HIMA trade-mark. Unless noted otherwise, this also applies to other manufacturers and their respective products referred to herein.

All of the instructions and technical specifications in this manual have been written with great care and effective quality assurance measures have been implemented to ensure their validity. For questions, please contact HIMA directly. HIMA appreciates any suggestion on which information should be included in the manual.

Equipment subject to change without notice. HIMA also reserves the right to modify the written material without prior notice.

For further information, refer to the CD-ROM and our website <http://www.hima.de> and <http://www.hima.com>.

© Copyright 2010, HIMA Paul Hildebrandt GmbH + Co KG

All rights reserved

Contact

HIMA Address

HIMA Paul Hildebrandt GmbH + Co KG

P.O. Box 1261

68777 Brühl, Germany

Tel: +49 6202 709-0

Fax: +49 6202 709-107

E-mail: info@hima.com

Revision index	Revisions	Type of Change	
		technical	editorial
1.00	Added: Configuration with SILworX, Chapter <i>Connection Variants</i>	X	X
1.01	Deleted: Chapter <i>Monitoring the Temperature State</i> displaced into the system manual		X

Table of Contents

1	Introduction	7
1.1	Structure and Use of this Manual	7
1.2	Target Audience	8
1.3	Formatting Conventions	9
1.3.1	Safety Notes	9
1.3.2	Operating Tips	10
2	Safety	11
2.1	Intended Use	11
2.1.1	Environmental Requirements	11
2.1.2	ESD Protective Measures	11
2.2	Residual Risk	12
2.3	Safety Precautions	12
2.4	Emergency Information	12
3	Product Description	13
3.1	Safety Function	13
3.1.1	Safety-Related Digital Inputs	13
3.1.1.1	Reaction in the Event of a Fault	14
3.1.1.2	Line Control	14
3.1.2	Safety-Related Digital Outputs	15
3.1.2.1	Reaction in the Event of a Fault	15
3.1.3	Safety-Related Counter	16
3.1.3.1	Reaction in the Event of a Fault	16
3.1.4	Safety-Related Analog Inputs	17
3.1.4.1	Line Monitoring for Digital Outputs	18
3.1.4.2	Reaction in the Event of a Fault	19
3.2	Equipment, Scope of Delivery	20
3.2.1	IP Address and System ID (SRS)	20
3.3	Type Label	21
3.4	Assembly	22
3.4.1	LED Indicators	23
3.4.1.1	Operating Voltage LED	23
3.4.1.2	System LEDs	24
3.4.1.3	Communication LEDs	25
3.4.1.4	I/O LEDs	25
3.4.1.5	Fieldbus LEDs	25
3.4.2	Communication	26
3.4.2.1	Connections for Ethernet Communication	26
3.4.2.2	Network Ports Used for Ethernet Communication	26
3.4.2.3	Connections for Fieldbus Communication	27
3.4.3	Pin Assignments	27
3.4.3.1	Pin Assignment of D-sub Connectors FB1 and FB2	27
3.4.3.2	Pin Assignment of D-sub Connectors FB1 and FB2	28

Table of Contents		F35
3.4.3.3	Pin Assignment of D-sub Connectors FB1 and FB2	28
3.4.3.4	Pin Assignment of D-sub Connectors FB1 and FB2	28
3.4.3.5	Pin Assignment of D-sub Connectors FB1 and FB2	29
3.4.3.6	Pin Assignment of the D-sub Connector FB3.....	29
3.4.4	Mode of Operation of the Counters	30
3.4.4.1	Counter Function 1 (Depending on the Count Direction Input Signal)	30
3.4.4.2	Counter Function 2 (Irrespective of the Count Direction Input Signal)	30
3.4.4.3	Decoder Operation for Gray Code.....	31
3.4.4.4	Comparing the Codes Used	31
3.4.5	Reset Key	32
3.4.6	Hardware Clock	32
3.5	Product Data	33
3.5.1	Product Data HIMatrix F35 011 (-20 °C)	35
3.5.2	Product Data HIMatrix F35 012 (Subsea / -20 °C)	36
3.6	Certified HIMatrix F35	37
4	Start-Up	38
4.1	Installation and Mounting	38
4.1.1	Connecting the Digital Inputs	38
4.1.2	Connecting the Digital Outputs.....	39
4.1.3	Connecting the Counters.....	39
4.1.4	Connecting the Analog Inputs	40
4.1.4.1	Shunt Adapter	41
4.1.5	Mounting the F35 in Zone 2	42
4.2	Configuration	43
4.3	Configuring the Controller with SILworX.....	43
4.3.1	Parameters and Error Codes for the Inputs and Output.....	43
4.3.2	Digital Outputs F35.....	44
4.3.2.1	Module Tab.....	44
4.3.2.2	DO 8: Channels Tab	45
4.3.3	Counter F35	46
4.3.3.1	Module Tab.....	46
4.3.4	Analog and Digital Inputs F35	48
4.3.4.1	Module Tab.....	48
4.3.4.2	MI 24/8 FS 1000: AI Channels Tab.....	49
4.3.4.3	MI 24/8 FS1000: DI Channels Tab.....	50
4.4	Configuring a Controller Using ELOP II Factory	51
4.4.1	Configuring the Inputs and Outputs.....	51
4.4.2	Signals and Error Codes for the Inputs and Outputs.....	51
4.4.3	Digital Inputs F35	52
4.4.4	Analog Inputs F35	54
4.4.5	Digital Outputs F35.....	56
4.4.6	Counter F35	57
4.5	Connection Variants.....	59
4.5.1	Wired Mechanical Contacts on Analog Inputs.....	59

4.5.1.1	Switching Thresholds of AI for Mechanical Contacts	60
4.5.1.2	Switching Thresholds of the Digital Inputs Used for Monitoring	60
4.5.2	Wired Mechanical Contacts on Digital Inputs	61
4.5.2.1	Switching Thresholds of the Digital Inputs for Mechanical Contacts	62
4.5.2.2	Digital Input Used for Monitoring	62
5	Operation	63
5.1	Handling.....	63
5.2	Diagnosis.....	63
6	Maintenance	64
6.1	Faults	64
6.1.1	Operating System Version 6.42 and Beyond.....	64
6.1.2	Operating System Versions Prior to 6.42.....	64
6.2	Maintenance Measures.....	64
6.2.1	Loading the Operating System	64
6.2.2	Proof Test	64
7	Decommissioning	65
8	Transport	66
9	Disposal	67
	Appendix	69
	Glossary.....	69
	Index of Figures	70
	Index of Tables.....	71
	Index.....	73

1 Introduction

This manual describes the technical characteristics of the device and its use. It also includes instructions on how to install, start up and replace it.

1.1 Structure and Use of this Manual

The content of this manual is part of the hardware description of the HIMatrix programmable electronic system.

This manual is organized in the following main chapters:

- Introduction
- Safety
- Product Description
- Start-Up
- Operation
- Maintenance
- Decommissioning
- Transport
- Disposal

This manual distinguishes between the following variants of the HIMatrix system:

Programming tool	Processor operating system	Communication operating system
SILworX	Version 7 and beyond	Version 12 and beyond
ELOP II Factory	Versions prior to 7	Versions prior to 12

Table 1: HIMatrix System Variants

The manual distinguishes among the different variants using:

- Separated chapters
- Tables differentiating among the versions, e.g., version 7 and beyond, or prior to version 7

i

Projects created with ELOP II Factory cannot be edited with SILworX, and vice versa!

i

This manual usually refers to compact controllers and remote I/Os as *devices*, and to the plug-in cards of a modular controller as *modules*.

1 Introduction**F35**

Additionally, the following documents must be taken into account:

Name	Content	Document number
HIMatrix System Manual Compact Systems	Hardware description of the HIMatrix compact systems	HI 800 141 E
HIMatrix System Manual Modular System F60	Hardware description of the HIMatrix modular system	HI 800 191 E
Himatrix Safety Manual	Safety functions of the HIMatrix system	HI 800 023 E
HIMatrix Engineering Manual	Project planning description for HIMatrix systems	HI 800 101 E
HIMax Communication Manual	Description of the communication protocols, ComUserTask and their configuration in SILworX	HI 801 101 E
HIMatrix PROFIBUS DP Master/Slave Manual	Description of the PROFIBUS protocol and its configuration in ELOP II Factory	HI 800 009 E
HIMatrix Modbus Master/Slave Manual	Description of the Modbus protocol and its configuration in ELOP II Factory	HI 800 003 E
HIMatrix TCP S/R Manual	Description of the TCP S/R protocol and its configuration in ELOP II Factory	HI 800 117 E
HIMatrix ComUserTask (CUT) Manual	Description of the ComUserTask and its configuration in ELOP II Factory	HI 800 329 E
SILworX Online Help	Instructions on how to use SILworX	-
ELOP II Factory Online Help	Instructions on how to use ELOP II Factory, Ethernet IP protocol, INTERBUS protocol	-
First Steps SILworX	Introduction to SILworX using the HIMax system as an example	HI 801 103 E
First Steps ELOP II Factory	Introduction to ELOP II Factory	HI 800 006 E

Table 2: Additional Relevant Documents

The latest manuals can be downloaded from the HIMA website www.hima.com. The revision index on the footer can be used to compare the current version of existing manuals with the Internet edition.

1.2 Target Audience

This document addresses system planners, configuration engineers, programmers of automation devices and personnel authorized to implement, operate and maintain the modules and systems. Specialized knowledge of safety-related automation systems is required.

1.3 Formatting Conventions

To ensure improved readability and comprehensibility, the following fonts are used in this document:

Bold:	To highlight important parts Names of buttons, menu functions and tabs that can be clicked and used in the programming tool.
<i>Italics:</i>	For parameters and system variables
Courier	Literal user inputs
RUN	Operating state are designated by capitals
Chapter 1.2.3	Cross references are hyperlinks even though they are not particularly marked. When the cursor hovers over a hyperlink, it changes its shape. Click the hyperlink to jump to the corresponding position.

Safety notes and operating tips are particularly marked.

1.3.1 Safety Notes

The safety notes are represented as described below.

These notes must absolutely be observed to reduce the risk to a minimum. The content is structured as follows:

- Signal word: danger, warning, caution, notice
- Type and source of danger
- Consequences arising from the danger
- Danger prevention

SIGNAL WORD



Type and source of danger!
Consequences arising from the danger
Danger prevention

The signal words have the following meanings:

- Danger indicates hazardous situation which, if not avoided, will result in death or serious injury.
- Warning indicates hazardous situation which, if not avoided, could result in death or serious injury.
- Caution indicates hazardous situation which, if not avoided, could result in minor or modest injury.
- Notice indicates a hazardous situation which, if not avoided, could result in property damage.

NOTE



Type and source of damage!
Damage prevention

1 Introduction**F35****1.3.2 Operating Tips**

Additional information is structured as presented in the following example:

i

The text corresponding to the additional information is located here.

Useful tips and tricks appear as follows:

TIP

The tip text is located here.

2 Safety

The following safety information, notes and instructions must be strictly observed. The product may only be used if all guidelines and safety instructions are adhered to.

This product is operated with SELV or PELV. No imminent danger results from the product itself. The use in Ex-Zone is permitted if additional measures are taken.

2.1 Intended Use

HIMatrix components are designed for assembling safety-related controller systems.

When using the components in the HIMatrix system, comply with the following general requirements

2.1.1 Environmental Requirements

Requirement type	Range of values ¹⁾
Protection class	Protection class III in accordance with IEC/EN 61131-2
Ambient temperature	0...+60 °C
Storage temperature	-40...+85 °C
Pollution	Pollution degree II in accordance with IEC/EN 61131-2
Altitude	< 2000 m
Housing	Standard: IP20
Supply voltage	24 VDC
¹⁾ The values specified in the technical data apply and are decisive for devices with extended environmental requirements.	

Table 3: Environmental Requirements

Exposing the HIMax system to environmental conditions other than those specified in this manual can cause the HIMatrix system to malfunction.

2.1.2 ESD Protective Measures

Only personnel with knowledge of ESD protective measures may modify or extend the system or replace devices.

NOTE



Device damage due to electrostatic discharge!

- When performing the work, make sure that the workspace is free of static, and wear an ESD wrist strap.
- If not used, ensure that the device is protected from electrostatic discharge, e.g., by storing it in its packaging.

2.2 Residual Risk

No imminent danger results from a HIMatrix system itself.

Residual risk may result from:

- Faults in the engineering
- Faults in the user program
- Faults in the wiring

2.3 Safety Precautions

Observe all local safety requirements and use the protective equipment required on site.

2.4 Emergency Information

A HIMatrix system is a part of the safety equipment of a site. If a device or a module fails, the site adopts the safe state.

In case of emergency, no action that may prevent the HIMatrix systems from operating safely is permitted.

3 Product Description

The safety-related **F35** controller is a compact system located in a metal enclosure with 24 digital inputs, 8 digital outputs, 2 counters and 8 analog inputs.

The controller is available in 3 model variants for SILworX and 3 model variants for ELOP II Factory, see Chapter 3.2. All variants are described in this manual.

The device is suitable for mounting in Ex-zone 2, see Chapter 4.1.5.

The device has been certified by the TÜV for safety-related applications up to SIL 3 (IEC 61508, IEC 61511 and IEC 62061), Cat. 4 (EN 954-1) and PL e (EN ISO 13849-1). Further safety standards, application standards and test standards are specified in the certificate available on the HIMA website.

3.1 Safety Function

The controller is equipped with safety-related digital inputs and outputs, safety-related counters and safety-related analog inputs.

3.1.1 Safety-Related Digital Inputs

The controller is equipped with 24 digital inputs. The state (HIGH, LOW) of each input is signaled by an individual LED.

The input signals are captured as analog measurements and provided to the program as a range of INT values from 0...3000 (0...30 V). Configurable thresholds are used to generate BOOL values, see Table 26

The default setting is:

Low level: < 7 V High level: > 13 V

The thresholds are set using system parameters taking the safety-related accuracy into account, see Table 43 and Table 44.

i

The LEDs for the digital inputs are activated by the program if the F35 is in RUN.

Mechanical contacts without own power supply or signal power source can be connected to the inputs. Potential-free mechanical contacts without own power supply are fed via an internal short-circuit-proof 24 V power source (LS+). Each of them supply a group of 8 mechanical contacts. Figure 1 shows how the connection is performed.

With signal voltage sources, the corresponding ground must be connected to the input (L-), see Figure 1.

3 Product Description

F35

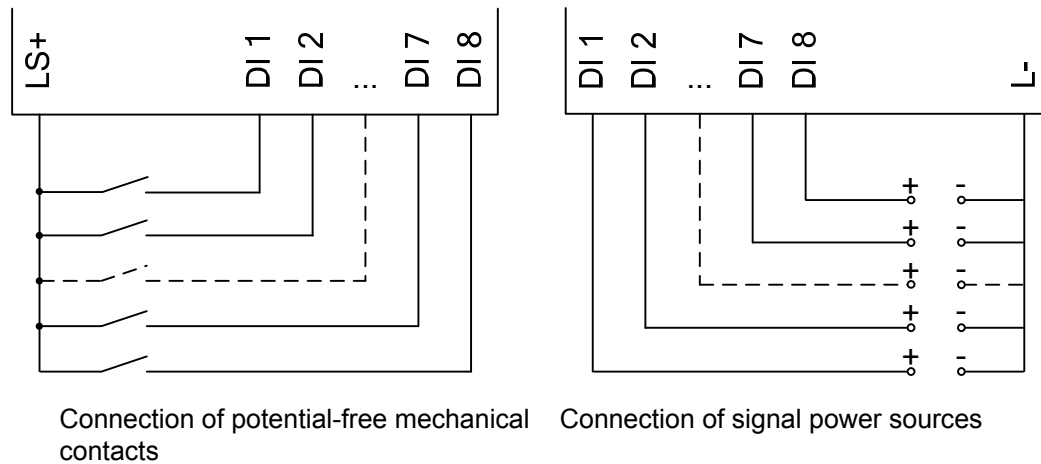

Figure 1: Connections to Safety-Related Digital Inputs

For the external wiring and the connection of sensors, apply the de-energized-to-trip principle. Thus, if a fault occurs, the input signals adopt a de-energized, safe state (low level).

An external wire is not monitored, however, an open-circuit is considered as safe low level.

3.1.1.1 Reaction in the Event of a Fault

If the device detects a fault on a digital input, the user program processes a low level in accordance with the de-energized to trip principle.

The device activates the *FAULT* LED.

In addition to the channel signal value, the user program must also consider the corresponding error code.

The error code allows the user to configure additional fault reactions in the user program.

3.1.1.2 Line Control

Line control cannot be configured for the F35 system, e.g., on EMERGENCY STOP inputs complying with Cat. 4 in accordance with EN 954-1.

Line monitoring for digital outputs is possible, see chapter 3.1.4.1.

3.1.2 Safety-Related Digital Outputs

The controller is equipped with 8 digital outputs. The state (HIGH, LOW) of each output is signaled by an individual LED.

At the maximum ambient temperature, each of the outputs 1...3 and 5...7 can be loaded with 0.5 A, and outputs 4 and 8 can be loaded with 1 A or 2 A at an ambient temperature of up to 50 °C.

If an overload occurs, one or all outputs are switched off. If the overload is removed, the outputs are switched on again automatically, see Table 28.

The external wire of an output is not monitored, however, a detected short-circuit is signaled.

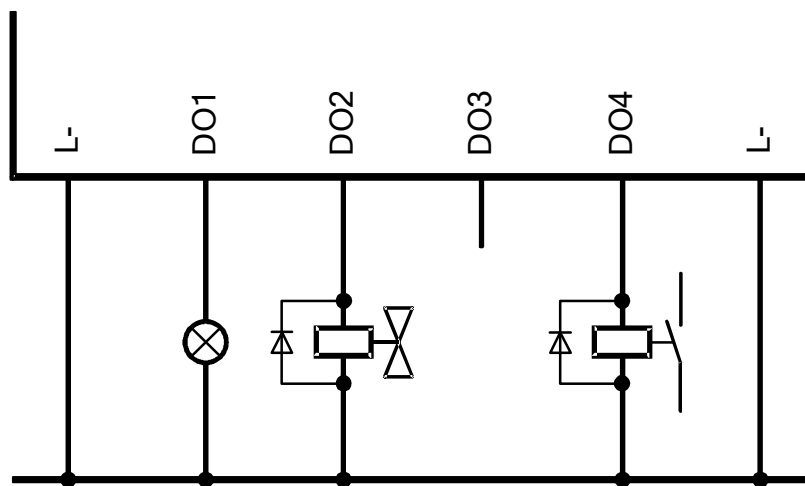

Figure 2: Connection of Actuators to Outputs

⚠ WARNING



For connecting a load to a 1-pole switching output, use the corresponding L- ground of the respective channel group (2-pole connection) to ensure that the internal protective circuit can function.

Inductive loads may be connected with no free-wheeling diode on the actuator. However, HIMA strongly recommends connecting a protective diode directly to the actuator.

3.1.2.1 Reaction in the Event of a Fault

If the device detects a faulty signal on a digital output, the affected module output is set to the safe (de-energized) state using the safety switches.

If a fault in the device occurs, all digital outputs are switched off.

In both cases, the device activates the *FAULT* LED.

The error code allows the user to configure additional fault reactions in the user program.

3 Product Description

F35

3.1.3 Safety-Related Counter

The controller is equipped with 2 independent counters with inputs that can be configured for 5 V or 24 V voltage level.

The required voltage level is determined by the user program with the *Counter[0x].5/24V Mode* system parameter.

Input A is the counter input, B is the count direction input and input Z (zero track) is used to reset.

Alternatively, all inputs are 3-bit Gray code inputs (in decoder operation)

The following modes of operation can be implemented:

- Counter function 1 (depending on the count direction input signal)
- Counter function 2 (not depending on the count direction input signal)
- Decoder operation with attached absolute rotary transducer

Refer to Chapter 3.4.4 for the description of the counters configuration.

The safety-related counter has a 24-bit resolution, the maximum counter reading is $2^{24} - 1$ (= 16 777 215).

3.1.3.1 Reaction in the Event of a Fault

If the device detects a fault in the counter section, a status bit is set for evaluation in the user program.

The device activates the *FAULT* LED.

In addition to the status bit, the user program must also consider the corresponding error code.

The error code allows the user to configure additional fault reactions in the user program.

3.1.4 Safety-Related Analog Inputs

The controller is equipped with 8 analog inputs with transmitter supplies for the unipolar measurement of voltages of 0...10 V, referenced to L-. With a shunt, also currents of 0...20 mA can be measured.

Input channels	Polarity	Current, voltage	Range of values in the application		Safety-related accuracy
			FS1000 ¹⁾	FS2000 ¹⁾	
8	unipolar	0...+10 V	0...1000	0...2000	2 %
8	unipolar	0...20 mA	0...500 ²⁾ 0...1000 ³⁾	0...1000 ²⁾ 0...2000 ³⁾	2 %

¹⁾ can be configured by selecting the type in the programming tool
²⁾ with external Z 7301 shunt adapter, see 4.1.4.1
³⁾ with external Z 7302 shunt adapter, see 4.1.4.1

Table 4: Input Values for the Analog Inputs

The resolution of the voltage and the current values depends on the parameter set in the properties of the controller.

In SILworX, the *FS 1000 / FS 2000* system parameter can be selected in the Module tab (Module of the digital and analog inputs MI 24/8). Depending on the selection, different resolutions result in the user program for the *-> Value [INT]* system parameter, see Chapter 4.3.4.1. To monitor the *-> Value [INT]* parameter, evaluate the corresponding *-> Error Code [BYTE]* fault value in the user program.

In ELOP II Factory, set the 1000 resolution (MI 24/8 FS 1000) or 2000 resolution (MI 24/8 FS 2000) in the Type field (menu: Properties, module: Analog Inputs). Depending on the selection, different resolutions result in the user program for the *AI[xx].Value* system parameter, see Chapter 4.4.4. To monitor the *AI[xx].Value* parameter, evaluate the corresponding *AI[xx].Error Code* parameter in the user program.

The input signals are evaluated in accordance with the de-energized to trip principle.

Only shielded cables with a length of a maximum of 300 m must be connected to the analog inputs. Each analog input must be connected to a twisted pair of wires. The shielding must be connected to the controller and the sensor housing and earthed of one end to the controller side to form a Faraday cage.

Unused analog inputs must be short-circuited.

If an open-circuit occurs during voltage measurement (the line is not monitored), any input signals are processed on the high-resistance inputs. The value resulting from this fluctuating input voltage is not reliable. Therefore with voltage inputs, the channels must be terminated by a 10 kΩ resistor. The internal resistance of the source must be taken into account.

For a current measurement with the shunt connected in parallel, the 10 kΩ resistor is not required.

The analog inputs have a common ground L-.

The analog inputs are designed to retain the metrological accuracy for 10 years. A recalibration must be carried out every 10 years.

3 Product Description

F35

3.1.4.1 Line Monitoring for Digital Outputs

The analog inputs can be used to monitor the digital outputs for short-circuits and open-circuits.

Figure 3 shows a circuitry for line monitoring (open circuits and short-circuits) that complies with SIL 3. Additionally, the S1 supply voltage is monitored via a digital input DI.

In this application, the actuator (e.g., solenoid valve) is connected to the digital output between DO and L-.

All specified electronic components must be directly attached to the clamps.

The reaction to open-circuits and short-circuits must be configured in the user program.

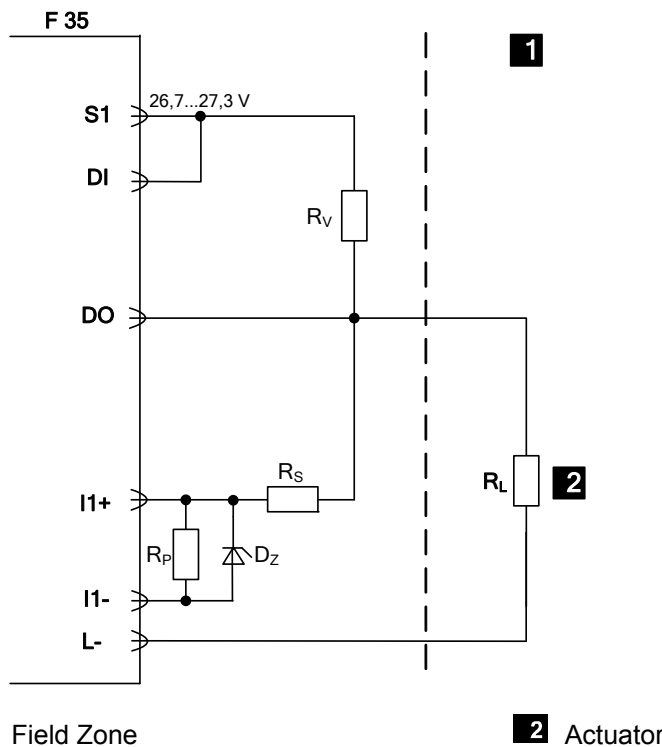

Figure 3: Circuitry for Line Monitoring

Designation	Value	Description
R _v	2.0 kΩ / 0.5 W	Resistor
R _s	2.0 kΩ / 0.5 W	Resistor
R _p	100 kΩ	Resistor
D _z	11 V ± 5 % / 0.3 W	Z-diode
R _L	75 Ω	Load resistor (e.g., solenoid valve)

Table 5: Values for Circuitry for Line Monitoring

3.1.4.2 Reaction in the Event of a Fault

If the device detects a fault on an analog input, the *AI.Error Code* system parameter > 0 is set. In case of module faults, the *Mod. Error Code* system parameter > 0 is set.

In both cases, the device activates the *FAULT* LED.

In addition to the analog value the error code must be evaluated. The analog value must be configured to ensure a safety-related reaction.

The error code allows the user to configure additional fault reactions in the user program.

3 Product Description

F35

3.2 Equipment, Scope of Delivery

The available components and their part numbers are listed below:

Designation	Description	Part no.
F35 01	Compact controller with 24 digital inputs, 8 digital outputs, 2 counters and 8 analog inputs, operating temperature 0...+60 °C, for ELOP II Factory programming tool	98 2200416
F35 011 (-20 °C)	Compact controller with 24 digital inputs, 8 digital outputs, 2 counters and 8 analog inputs, operating temperature -20...+60 °C, for ELOP II Factory programming tool	98 2200453
F35 012 (subsea / -20 °C)	Compact controller with 24 digital inputs, 8 digital outputs, 2 counters and 8 analog inputs, operating temperature -20...+60 °C, designed for subsea-use according to ISO 13628-6: 2006, for ELOP II Factory programming tool	98 2200454
F35 01 SILworX	Compact controller with 24 digital inputs, 8 digital outputs, 2 counters and 8 analog inputs, operating temperature 0...+60 °C, for SILworX programming tool	98 2200473
F35 011 SILworX (-20 °C)	Compact controller with 24 digital inputs, 8 digital outputs, 2 counters and 8 analog inputs, operating temperature -20...+60 °C, for SILworX programming tool	98 2200476
F35 012 SILworX (subsea / -20 °C)	Compact controller with 24 digital inputs, 8 digital outputs, 2 counters and 8 analog inputs, operating temperature -20...+60 °C, designed for subsea-use according to ISO 13628-6: 2006, for SILworX programming tool.	98 2200477

Table 6: Part Numbers

3.2.1 IP Address and System ID (SRS)

A transparent label is delivered with the device to allow one to note the IP address and the system ID (SRS for system rack slot) after a change.

IP ____ . ____ . ____ . ____ SRS ____ . ____ . ____

Default value for IP address: 192.168.0.99

Default value for SRS: 60000.0.0

The label must not be affixed such that the air vents on the cabinet are covered.

Refer to the First Steps manual of the programming tool for more information on how to modify the IP address and the system ID.

3.3 Type Label

The type plate contains the following details:

- Product name
- Bar code (1D or 2D code)
- Part no.
- Production year
- Hardware revision index (HW Rev.)
- Firmware revision index (FW Rev.)
- Operating voltage
- Mark of conformity

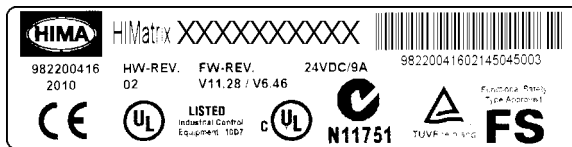

Figure 4: Sample Type Label

3 Product Description

F35

3.4 Assembly

This chapter describes the layout and function of the controller, and its connection for communication.

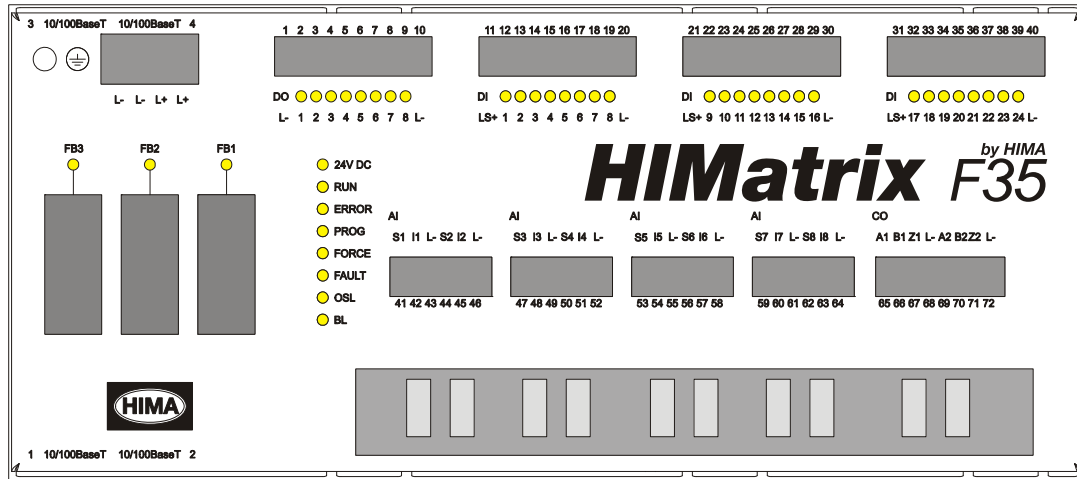
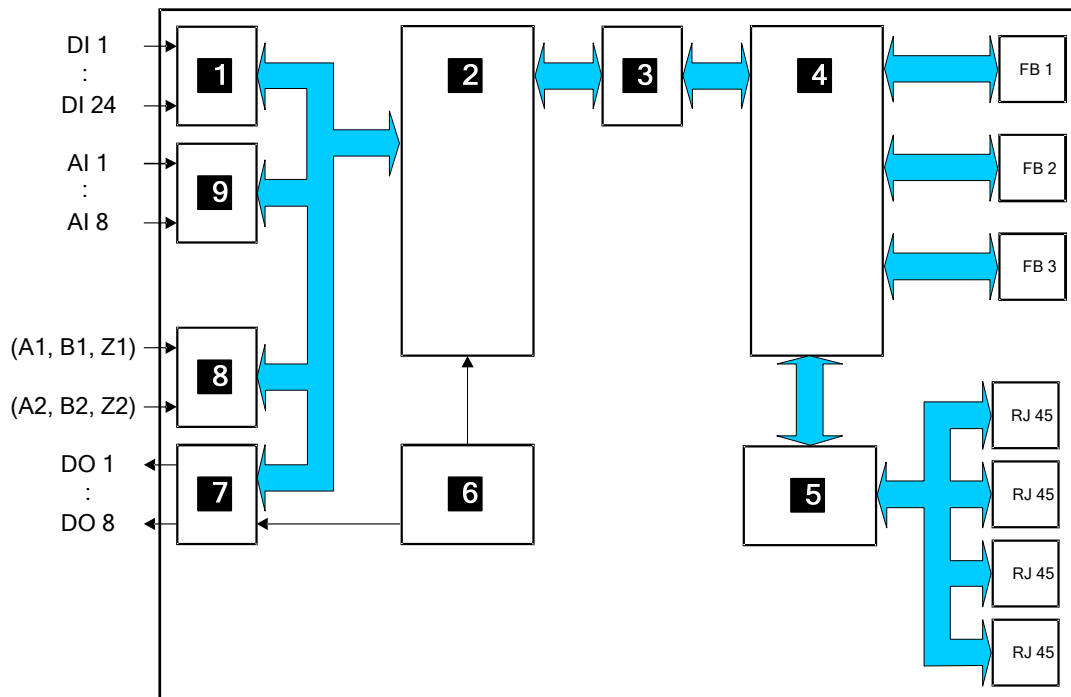

Figure 5: Front View



- | | |
|--|------------------------------|
| 1 Digital Inputs | 6 Watchdog |
| 2 Safety-Related Processor System | 7 Digital Outputs |
| 3 Dual Port RAM | 8 Counter, 2 Channels |
| 4 Communication System | 9 Analog Inputs |
| 5 Switch | |

Figure 6: Block Diagram

3.4.1 LED Indicators

The light-emitting diodes (LEDs) indicate the operating state of the controller. The LEDs are classified as follows:

- Operating Voltage LED
- System LEDs
- Communication LED
- I/O LEDs
- Fieldbus LEDs

3.4.1.1 Operating Voltage LED

LED	Color	Status	Description
24 VDC	Green	On	24 VDC operating voltage present
		Off	No operating voltage

Table 7: Operating Voltage LED

3 Product Description**F35****3.4.1.2 System LEDs**

While the system is being booted, all LEDs are lit simultaneously.

LED	Color	Status	Description
RUN	Green	On	Device in RUN, normal operation A loaded user program is being executed (not with remote I/Os).
		Blinking	Device in STOP A new operating system is being loaded.
		Off	The device is not in the RUN state.
ERROR	Red	On	The device is in the ERROR STOP state. Internal fault detected by self-tests e.g., hardware fault, software error or cycle time overrun. The processor system can only be restarted with a command from the PADT (reboot).
		Blinking	If ERROR blinks and all others LEDs are lit simultaneously, the boot loader has detected an operating system fault in the flash memory and waits for a new operating system to be loaded.
		Off	No faults detected.
PROG	Yellow	On	A new configuration is being loaded into the device.
		Blinking	The device switches from INIT to STOP A new operating system is being loaded into the flash ROM.
		Off	No configuration or operating system is being loaded.
FORCE	Yellow	On	The device is in RUN, forcing was activated.
		Blinking	The device is in STOP, forcing has been prepared and is activated when the device is started.
		Off	Forcing is not activated. The FORCE LED of a remote I/O is not functioning. The FORCE LED of the associated controller serves to signal the forcing of a remote I/O.
FAULT	Yellow	On	The loaded configuration is defective. The new operating system is corrupted (after OS download).
		Blinking	Fault while loading a new operating system One or multiple I/O faults occurred.
		Off	None of the described faults occurred.
OSL	Yellow	Blinking	Operating system emergency loader active.
		Off	Operating system emergency loader inactive.
BL	Yellow	Blinking	OS and OLS binary defective or INIT_FAIL hardware fault.
		Off	Boot loader inactive

Table 8: System LEDs

F35**3 Product Description****3.4.1.3 Communication LEDs**

All RJ-45 connectors are provided with a green and a yellow LED. The LEDs signal the following states:

LED	Status	Description
Green	On	Full duplex operation
	Blinking	Collision
	Off	Half duplex operation, no collision
Yellow	On	Connection available
	Blinking	Interface activity
	Off	No connection available

Table 9: Ethernet Indicators

3.4.1.4 I/O LEDs

LED	Color	Status	Description
DI 1...24	Yellow	On	The related input is active (energized).
		Off	The related input is inactive (de-energized).
DO 1...8	Yellow	On	The related output is active (energized).
		Off	The related output is inactive (de-energized).

Table 10: I/O LEDs

3.4.1.5 Fieldbus LEDs

The state of the communication is indicated by the FBx LED of the configured serial interface (FB1...3). The function of the LED depends on the used protocol.

Refer to the corresponding Communication Manual for more details on the function of the LEDs.

3 Product Description

F35

3.4.2 Communication

The controller communicates with remote I/Os via **safeethernet**.

3.4.2.1 Connections for Ethernet Communication

Property	Description
Port	4 x RJ-45
Transfer standard	10/100/Base-T, half and full duplex
Auto negotiation	Yes
Auto crossover	Yes
Connection socket	RJ-45
IP address	Freely configurable ¹⁾
Subnet mask	Freely configurable ¹⁾
Supported protocols	<ul style="list-style-type: none"> ▪ Safety-related: safeethernet ▪ non safety-related: EtherNet/IP²⁾, OPC, programming and debugging tool (PADT), TCP-SR, SNTP, Modbus-TCP
¹⁾ The general rules for assigning IP address and subnet masks must be adhered to.	
²⁾ EtherNet/IP is not supported in SILworX.	

Table 11: Ethernet Interfaces Properties

Two RJ-45 connectors with integrated LEDs are located on the top and on the bottom left-hand side of the enclosure. Refer to 3.4.1.3 for a description of the LEDs' function.

The connection parameters are read based on the MAC address (media access control address) defined during manufacturing.

The MAC address for the controller is specified on a label located above the two RJ-45 connectors (1 and 2).

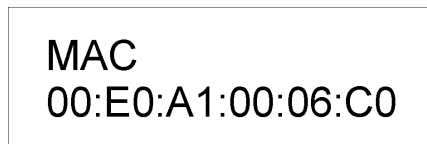

Figure 7: Sample MAC Address Label

The controller is equipped with an integrated switch for safety-related Ethernet communication (**safeethernet**). For further information on the integrated switch and **safeethernet**, refer to Chapter *Communication* of the System Manual for Compact Systems (HI 800 141 E).

3.4.2.2 Network Ports Used for Ethernet Communication

UDP ports	Use
8000	Programming and operation with the programming tool
8001	Configuration of the remote I/O using the PES (ELOP II Factory)
8004	Configuration of the remote I/O using the PES (SILworX)
6010	safeethernet and OPC
123	SNTP (time synchronization between PES and remote I/O, PES and external devices)
6005/ 6012	If TCS_DIRECT was not selected in the HH network
502	Modbus (can be modified by the user)
44818	EtherNet/IP session protocol for device identification
2222	EtherNet/IP Data Exchange

Table 12: Network Ports (UDP Ports) in Use

TCP ports	Use
502	Modbus (can be modified by the user)
xxx	TCP SR assigned by the user
44818	Ethernet/IP Explicit Messaging Services

Table 13: Network Ports (TCP Ports) in Use

3.4.2.3 Connections for Fieldbus Communication

The three 9-pole D-sub connectors are located on the front plate of the enclosure.

Designation	Fieldbus submodule	Protocols
FB 1 (with module)	PROFIBUS master PROFIBUS slave RS485 module RS232 module RS422 module INTERBUS master	PROFIBUS DP master PROFIBUS DP slave RS485 for Modbus (master or slave) and ComUserTask RS232 for ComUserTask RS422 for ComUserTask INTERBUS master ¹⁾
FB 2 (with module)	PROFIBUS master PROFIBUS slave RS485 module RS232 module RS422 module INTERBUS master	PROFIBUS DP master PROFIBUS DP slave RS485 for Modbus (master or slave) and ComUserTask RS232 for ComUserTask RS422 for ComUserTask INTERBUS master ¹⁾
FB 3	RS485	RS485 for Modbus (master or slave) and ComUserTask
¹⁾ INTERBUS is not supported in SILworX.		

Table 14: Connections for Fieldbus Communication

The fieldbus submodules for communication via FB1 and FB2 are optional and must be mounted by the manufacturer.

3.4.3 Pin Assignments

The following tables describe the Pin assignments of the fieldbus connectors.

3.4.3.1 Pin Assignment of D-sub Connectors FB1 and FB2

with fieldbus submodule for PROFIBUS DP master or slave

Connection	Signal	Function
1	---	---
2	---	---
3	RxD/TxD-A	Receive/send data A
4	RTS	Control signal
5	DGND	Data ground
6	VP	5 V, plus pole supply voltage
7	---	---
8	RxD/TxD-B	Receive/send data B
9	---	---

Table 15: Pin Assignment of D-sub Connectors FB1 and FB2 for PROFIBUS DP

3 Product Description**F35****3.4.3.2 Pin Assignment of D-sub Connectors FB1 and FB2**

with RS485 fieldbus submodule for Modbus master or slave and ComUserTask

Connection	Signal	Function
1	---	---
2	RP	5 V decoupled with diodes
3	RxD/TxD-A	Receive/send data A
4	CNTR-A	Control signal A
5	DGND	Data ground
6	VP	5 V, plus pole supply voltage
7	---	---
8	RxD/TxD-B	Receive/send data B
9	CNTR-B	Control signal B

Table 16: Pin Assignment of the D-sub Connectors FB1 and FB2 for RS485

3.4.3.3 Pin Assignment of D-sub Connectors FB1 and FB2

with RS232 fieldbus submodule for ComUserTask

Connection	Signal	Function
1	---	---
2	TxD	Send data
3	RxD	Receive data
4	---	---
5	DGND	Data ground
6	---	---
7	RTS	Request to send
8	---	---
9	---	---

Table 17: Pin Assignment of the D-sub Connectors FB1 and FB2 for RS232

3.4.3.4 Pin Assignment of D-sub Connectors FB1 and FB2

with RS422 fieldbus submodule for ComUserTask

Connection	Signal	Function
1	---	---
2	RP	+5 V decoupled with diodes
3	RxA	Receive data A
4	TxA	Send data A
5	DGND	Data ground
6	VP	+5 V supply voltage
7	---	---
8	RxB	Receive data B
9	TxB	Send data B

Table 18: Pin Assignment of the D-sub Connectors FB1 and FB2 for RS422

F35**3 Product Description**

3.4.3.5 Pin Assignment of D-sub Connectors FB1 and FB2 with fieldbus submodule for INTERBUS

Connection	Signal	Function
1	DO	Positive data output
2	DI	Positive data input
3	COM	Common 0 V line
4	---	---
5	---	---
6	DO-	Negative data input
7	DI-	Negative data output
8	---	---
9	---	---

Table 19: Pin Assignment of the D-sub Connectors FB1 and FB2 for INTERBUS

3.4.3.6 Pin Assignment of the D-sub Connector FB3 Modbus master or slave

Connection	Signal	Function
1	---	---
2	---	---
3	RxD/TxD-A	Receive/send data A
4	CNTR-A	Control signal A
5	DGND	Data ground
6	VP	5 V, plus pole supply voltage
7	---	---
8	RxD/TxD-B	Receive/send data B
9	CNTR-B	Control signal B

Table 20: Pin Assignment of D-sub Connector FB3 for Modbus

3 Product Description

F35

3.4.4 Mode of Operation of the Counters

Both counters for the F35 are configured via system variables which are described in Table 40 and Table 47.

The following modes of operation can be implemented:

3.4.4.1 Counter Function 1 (Depending on the Count Direction Input Signal)

Counter[0x].Auto. Advance Sense system variable set to TRUE, counting with falling edge on input A1 (A2).

Low level on count direction input B1 (B2) increments (increases) the counter value,
High level on count direction input B1 (B2) decrements (decreases) the counter value.

For this mode of operation, the Z1 input (Z2) must be set to low level. The counter can be reset with a short-time high level.

Configuration of counter function 1:

System variables	Description	Value
Counter[0x].5/24V Mode	Inputs 24 V 5 V	TRUE FALSE
Counter[0x].Auto. Advance Sense	Counter function 1 active	TRUE
Counter[0x].Direction	No function	FALSE
Counter[0x].Gray Code	Pulse operation active	FALSE
Counter[0x].Reset	Default Reset short-time	TRUE FALSE

Table 21: Configuration of Counter Function 1

3.4.4.2 Counter Function 2 (Irrespective of the Count Direction Input Signal)

The *Counter[0x].Auto. Advance Sense* set to FALSE, counting with falling edge on input A1 (A2).

The counter increment or decrement is not controlled externally via the input B1 (B2), but by the user program.

Counter[0x].Direction system variable is set to FALSE: counter value increment (higher value),

Counter[0x].Direction system variable is set to TRUE: counter value decrement (lower value).

Input B1 (B2) has no function.

The *Counter[0x].Reset* system variable can be reset via the user program.

Configuration of counter function 2:

System variables	Description	Value
Counter[0x].5/24V Mode	Inputs 24 V 5 V	TRUE FALSE
Counter[0x].Auto. Advance Sense	Counter function 2 active	FALSE
Counter[0x].Direction	Increment Decrement	FALSE TRUE
Counter[0x].Gray Code	Pulse operation active	FALSE
Counter[0x].Reset	Default Reset short-time	TRUE FALSE

Table 22: Configuration of Counter Function 2

3.4.4.3 Decoder Operation for Gray Code

The 3-bit Gray code of a rotary transducer connected to the inputs A1, B1, Z1 (A2, B2, Z2) is evaluated.

In the user program, use the *Counter[0x].Gray Code* system variable to define this mode of operation individually for each counter.

Configuration of decoder operation:

System variables	Description	Value
Counter[0x].5/24V Mode	Inputs 24 V 5 V	TRUE FALSE
Counter[0x].Auto. Advance Sense	Counter function 1 passive	FALSE
Counter[0x].Direction	No function	FALSE
Counter[0x].Gray Code	Decoder operation active	TRUE
Counter[0x].Reset	Default (no function)	TRUE

Table 23: Configuration of Decoder Operation

3.4.4.4 Comparing the Codes Used

When the counter is operated as a decoder in Gray code, only 1 bit may change when a value on the inputs changes.

3-bit Gray code	Decimal Value	Counter[0x].Value
000	0	0
001	1	1
011	2	3
010	3	2
110	4	6
111	5	7
101	6	5
100	7	4

Table 24: Comparison of the Codes Used

3 Product Description

F35

3.4.5 Reset Key

The controller is equipped with a reset key. The key is only required if the user name or password for administrator access is not known. If only the IP address set for the controller does not match the PADT (PC), the connection can be established with a `Route add` entry on the PC.

The key can be accessed through a small round hole located approximately 5 cm from the upper left-hand side of the enclosure. The key is engaged using a suitable pin made of insulating material to avoid short-circuits within the controller.

The reset is only effective if the controller is rebooted (switched off and on) while the key is simultaneously engaged for at least 20 seconds. Engaging the key during operation has no effect.

WARNING



Caution! Fieldbus communication may be disturbed!

Prior to switching on the controller with the reset key engaged, all device fieldbus connectors must be unplugged to ensure that the fieldbus communication among other stations is not disturbed.

The fieldbus plugs may only be plugged in again when the controller is in the RUN or STOP state.

Properties and behavior of the controller after a reboot with engaged reset key:

- Connection parameters (IP address and system ID) are set to the default values.
- All accounts are deactivated except for the administrator default account with empty password.
- With COM operating system version 10.42 and beyond, loading a user program or operating system with default connection parameters is inhibited!
The loading procedure is only allowed after the connection parameters and the account have been configured on the controller and the controller has been rebooted.

After a new reboot without the reset key engaged, the connection parameters (IP address and system ID) and accounts become effective.

- Those configured by the user.
- Those valid prior to rebooting with the reset key engaged, if no changes were performed.

3.4.6 Hardware Clock

In case of loss of operating voltage, the power provided by an integrated gold capacitor is sufficient to buffer the hardware clock for approximately one week.

3.5 Product Data

General	
User memory	Versions prior to 6.46 max. 500 kB user program max. 500 kB user data Version 6.100 max. 2047 kB user program max. 2047 kB user data Version 7 max. 1023 kB user program max. 1023 kB user data
Response time	≥ 20 ms
Interfaces: Ethernet PROFIBUS DP master/slave Modbus master/slave INTERBUS Master RS485 (Modbus M&S)	4 x RJ-45, 10/100BaseT (with 100 Mbit/s) with integrated switch D-sub connector, 9 poles (FB1, FBs) D-sub connector, 9 poles (FB3)
Operating voltage	24 VDC, -15 %...+20 %, $w_{ss} \leq 15 \%$, from a power supply unit with safe insulation in accordance with IEC 61131-2
Current input	max. 9 A (with maximum load) Idle: 0.5 A
Fuse (external)	10 A time-lag (T)
Buffer for date/time	Gold capacitor
Temperature class	T4 (Zone 2)
Operating temperature	0 °C...+60 °C
Storage temperature	-40 °C...+85 °C
Type of protection	IP20
Max. dimensions (without plug)	Width: 257 mm (with enclosure screws) Height: 114 mm (with fixing bolt) Depth: 97 mm (with earthing screw)
Weight	approx. 1.2 kg

Table 25: Product Data

3 Product Description**F35**

Digital inputs	
Number of inputs	24 (non-galvanically isolated)
Type of input	Current sinking logic, 24 V, type 1 in accordance with IEC 61131-2
High level -> voltage Current input	15 V (default value 13 V + 2 V, safety range can be configured up to 30 VDC) approx. 3.5 mA at 24 VDC, approx. 4.5 mA at 30 VDC
Low level -> voltage Current input	max. 5 V DC (default value 7 V - 2 V, safety distance can be freely configured up to max. high level of -4 V and min. 2 V) max. 1.5 mA (1 mA at 5 V)
Input resistance	< 7 k Ω
Overvoltage protection	- 10 V, +35 V
Max. wire length	300 m
Supply	3 x 20 V / 100 mA, short-circuit-proof
Measurement accuracy at 25 °C, max.	± 0.2 % of final value
Measurement accuracy on full temperature range, max.	± 1 % of final value
Temperature coefficient, max.	± 0.023 %/K of final value

Table 26: Specifications for the Digital Inputs

Analog inputs	
Number of inputs	8 (unipolar, non-galvanically isolated)
External shunt adapter for current measurement	Z 7301 (250 Ω) Z 7302 (500 Ω)
Nominal range	0...+10 VDC, 0...+20 mA with shunt 500 Ω
Operating range	-0.1...+11.5 VDC, -0.4...+23 mA with 500 Ω shunt
Input resistance	1 M Ω
Input line	max. 300 m, shielded, twisted pairs of wires
Internal resistance of the signal source	≤ 500 Ω
Digital resolution	12 bit
Measurement accuracy at 25 °C, max.	± 0.1 % of final value
Measurement accuracy on full temperature range, max.	± 0.5 % of final value
Temperature coefficient, max.	$\pm 0,011$ %/K of full scale
Safety-related accuracy, max.	± 2 % of final value
Measured value refresh	once per cycle of the controller
Sampling time	approx. 45 μ s
Transmitter supplies	8 x 24...28 V / ≤ 46 mA, short-circuit-proof

Table 27: Specifications for the Analog Inputs

F35

3 Product Description

Digital outputs	
Number of outputs	8 (non-galvanically isolated, common ground L-)
Output voltage	L+ minus 2 V
Output current	Channels 1...3 and 5...7: 0.5 A at 60 °C Channels 4 and 8: 1 A at 60 °C (2 A at 50 °C)
Minimum load	2 mA for each channel
Internal voltage drop	max. 2 W at 2 A
Leakage current (with low level)	max. 1 mA at 2 V
Behavior with overload	The affected output is switched off and cyclically switched on again
Total output current	max. 7 A, upon overload, all outputs are switched off and cyclically switched on again

Table 28: Specifications for the Digital Outputs

Counter	
Number of counters	2 (non-galvanically isolated)
Inputs	3 on each (A, B, Z)
Input voltages	5 V and 24 V
High level (5 V)	4...6 V
High level (24 V)	13...33 V
Low level (5 V)	0...0.5 V
Low level (24 V)	-3...5 V
Input currents	1.4 mA at 5 V 6.5 mA at 24 V
Input impedance	3.7 kΩ
Input line	max. 500 m, shielded, twisted pairs of wires
Counter resolution	24 bit
Min. pulse length	5 μs
Max. input frequency	100 kHz (at 5 V and 24 V input voltage)
Triggered	on negative edge
Edge steepness	1 V/μs
Pulse duty factor	1 : 1 (for 100 kHz)

Table 29: Specifications for the Counters

3.5.1 Product Data HIMatrix F35 011 (-20 °C)

The HIMatrix F35 011 model variant is intended for use at the extended temperature range of -20...+60 °C. The electronic components are coated with a protective lacquer.

HIMatrix F35 011 (-20 °C)	
Operating temperature	-20...+60 °C
Weight	1.2 kg

Table 30: Product Data F35 011 (-20 °C)

3 Product Description

F35

3.5.2 Product Data HIMatrix F35 012 (Subsea / -20 °C)

The HIMatrix F35 012 model variant is intended for subsea-use according to ISO 13628 Part 6: Subsea production control systems. The electronic components are coated with a protective lacquer. The enclosure of the controller is made of V2A stainless steel. The controller is intended for mounting on a mounting plate. The enclosure is equipped with a massive aluminum plate, see Figure 8. Figure 9 specifies the centre hole distances.

HIMatrix F35 012 (subsea / -20 °C)	
Enclosure material	V2A Stainless steel V2A
Operating temperature	-20...+60 °C
ISO 13628-6: 2006	Shock and vibration tests according to Level Q1 and Q2. Random vibration test, ESS (Environmental stress screening)
Max. dimensions (without connectors and aluminum plate)	Width: 257 mm (with enclosure screws) Height: 114 mm (with fixing bolt) Depth: 97 mm (with earthing rail)
Dimensions: Aluminum plate (W x H x D)	(200 x 136 x 6) mm
Weight	1.7 kg

Table 31: Product Data F35 012 (Subsea / -20 °C)

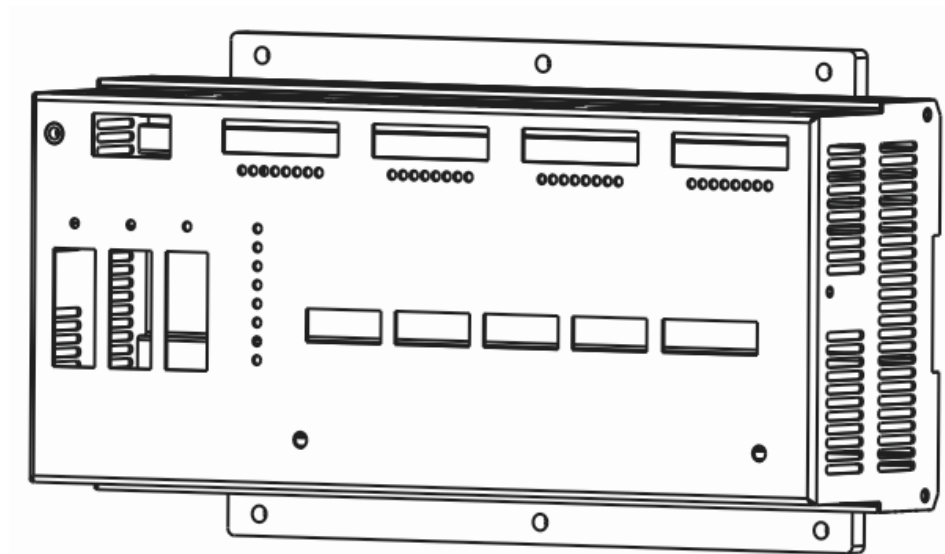

Figure 8: HIMatrix F35 Subsea / -20° with Aluminum Plate

F35

3 Product Description

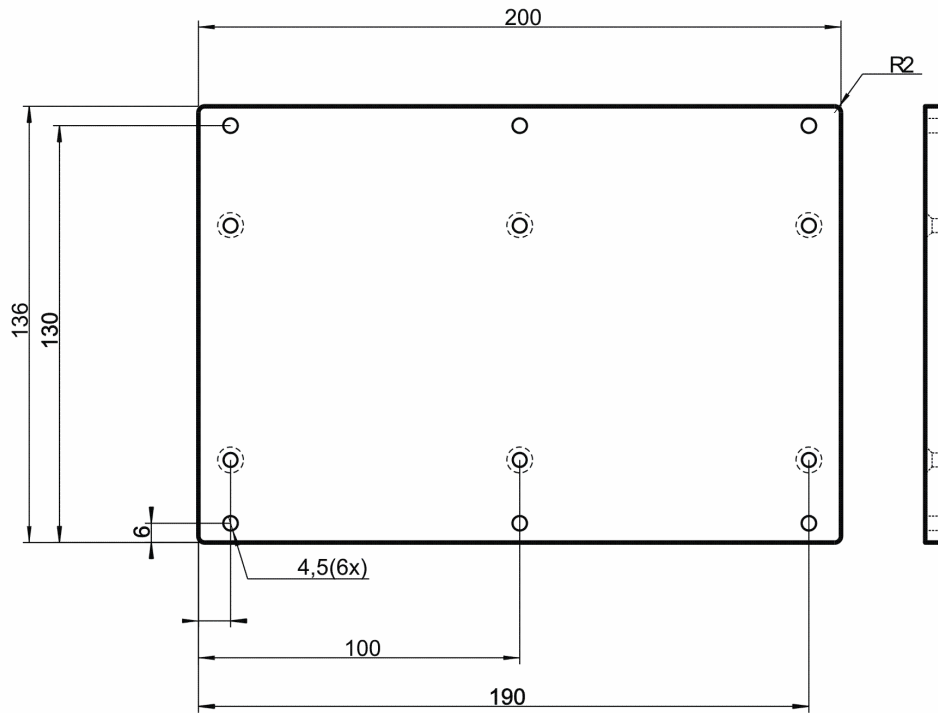

Figure 9: Aluminum Plate with Dimensions

3.6 Certified HIMatrix F35

HIMatrix F35	
CE	EMC, ATEX Zone 2
TÜV	IEC 61508 1-7:2000 up to SIL 3 IEC 61511:2004 EN 954-1:1996 up to Cat. 4
TÜV ATEX	94/9/EG EN 1127-1 EN 61508
Lloyd's Register	Shipping certification ENV1, ENV2 and ENV3. Test Specification Number: 1 - 2002
UL Underwriters Laboratories Inc.	ANSI/UL 508, NFPA 70 – Industrial Control Equipment CSA C22.2 No.142 UL 1998 Software Programmable Components NFPA 79 Electrical Standard for Industrial Machinery IEC 61508
FM Approvals	Class I, DIV 2, Groups A, B, C and D Class 3600, 1998 Class 3611, 1999 Class 3810, 1989 Including Supplement #1, 1995 CSA C22.2 No 142 CSA C22.2 No 213
PROFIBUS Nutzerorganisation (PNO)	Test Specification for PROFIBUS DP Slave, Version 3.0 November 2005

Table 32: Certificates

4 Start-Up

To start up the controller, it must be mounted, connected and configured in the programming tool.

4.1 Installation and Mounting

The controller is mounted on a 35 mm DIN rail or on a mounting plate for the F35 012 (subsea / -20 °C).

4.1.1 Connecting the Digital Inputs

Use the following terminals to connect the digital inputs:

Terminal	Designation	Function
11	LS+	Sensor supply of the inputs 1...8
12	1	Digital input 1
13	2	Digital input 2
14	3	Digital input 3
15	4	Digital input 4
16	5	Digital input 5
17	6	Digital input 6
18	7	Digital input 7
19	8	Digital input 8
20	L-	Ground
Terminal	Designation	Function
21	LS+	Sensor supply of the inputs 9...16
22	9	Digital input 9
23	10	Digital input 10
24	11	Digital input 11
25	12	Digital input 12
26	13	Digital input 13
27	14	Digital input 14
28	15	Digital input 15
29	16	Digital input 16
30	L-	Ground
Terminal	Designation	Function
31	LS+	Sensor supply of the inputs 17...24
32	17	Digital input 17
33	18	Digital input 18
34	19	Digital input 19
35	20	Digital input 20
36	21	Digital input 21
37	22	Digital input 22
38	23	Digital input 23
39	24	Digital input 24
40	L-	Ground

Table 33: Terminal Assignment for the Digital Inputs

4.1.2 Connecting the Digital Outputs

Use the following terminals to connect the digital outputs:

Terminal	Designation	Function
1	L-	Ground channel group
2	1	Digital output 1
3	2	Digital output 2
4	3	Digital output 3
5	4	Digital output 4 (for increased load)
6	5	Digital output 5
7	6	Digital output 6
8	7	Digital output 7
9	8	Digital output 8 (for increased load)
10	L-	Ground channel group

Table 34: Terminal Assignment for the Digital Outputs

4.1.3 Connecting the Counters

In the safety-related application (SIL 3 in accordance with IEC 61508) of the counters, the overall plant including the sensors or encoders connected must comply with the safety requirements. For more information, refer to the HIMatrix Safety Manual (HI 800 023 E).

Only shielded cables with a length of a maximum of 500 m must be connected to the counter inputs. Each counter input must be connected to a twisted pair of wires. The shielding must be connected at both ends.

All L- connections are interconnected on the controller as a common ground.

The counters are connected to the following terminals:

Terminal	Designation	Function
65	A1	Input A1 or bit 0 (LSB)
66	B1	Input B1 or bit 1
67	Z1	Input Z1 or bit 2 (MSB)
68	L-	Common ground
69	A2	Input A2 or bit 0 (LSB)
70	B2	Input B2 or bit 1
71	Z2	Input Z2 or bit 2 (MSB)
72	L-	Common ground

Table 35: Terminal Assignment for the Counters

Inputs that are not being used need not be terminated.

NOTE



Using the wrong terminal plugs may damage the controller or the sensors or encoders connected to it!

4.1.4 Connecting the Analog Inputs

Use the following terminals to connect the analog inputs:

Terminal	Designation	Function
41	S1	Transmitter supply 1
42	I1	Analog input 1
43	I1-	Ground
44	S2	Transmitter supply 2
45	I2	Analog input 2
46	I2-	Ground
Terminal	Designation	Function
47	S3	Transmitter supply 3
48	I3	Analog input 3
49	I3-	Ground
50	S4	Transmitter supply 4
51	I4	Analog input 4
52	I4-	Ground
Terminal	Designation	Function
53	S5	Transmitter supply 5
54	I5	Analog input 5
55	I5-	Ground
56	S6	Transmitter supply 6
57	I6	Analog input 6
58	I6-	Ground
Terminal	Designation	Function
59	S7	Transmitter supply 7
60	I7	Analog input 7
61	I7-	Ground
62	S8	Transmitter supply 8
63	I8	Analog input 8
64	I8-	Ground

Table 36: Terminal Assignment for the Analog Inputs

i

Only shielded cables with a length of a maximum of 300 m must be connected to the analog inputs. Each analog input must be connected to a twisted pair of wires. The shielding must be connected to the controller and the sensor housing and earthed of one end to the controller side to form a Faraday cage.

4.1.4.1 Shunt Adapter

The shunt adapter is a plug-in module for the analog inputs of the safety-related HIMatrix F35 controller.

Four variants are available:

Model	Equipment	Part no.
Z 7301	250 Ω shunt	98 2220059
Z 7302	500 Ω shunt	98 2220067
Z 7306	<ul style="list-style-type: none">▪ 250 Ω shunt▪ Overvoltage protection▪ HART series resistor (current limiting)	98 2220115
Z 7308	<ul style="list-style-type: none">▪ Voltage divider▪ Overvoltage protection	98 2220137

Table 37: Shunt Adapter

Refer to the corresponding manuals for further information on the shunt adapters.

4.1.5 Mounting the F35 in Zone 2

(EC Directive 94/9/EC, ATEX)

The controller is suitable for mounting in zone 2. Refer to the corresponding declaration of conformity available on the HIMA website.

When mounting the device, observe the special conditions specified in the following section.

Special Conditions X

1. Mount the HIMatrix F35 controller in an enclosure that meets the EN 60079-15 requirements and achieves a type of protection at least IP54, in accordance with EN 60529. Provide the enclosure with the following label:

Work is only permitted in the de-energized state

Exception:

If a potentially explosive atmosphere has been precluded, work can also be performed when the controller is under voltage.

2. The enclosure in use must be able to safely dissipate the generated heat. Depending on the output load and supply voltage, the HIMatrix F35 has a power dissipation ranging between 15 W and 29 W.
3. Protect the HIMatrix F35 with a 10 A time-lag fuse.
The F35 must be supplied with 24 VDC from a power supply unit with safe isolation. Use power supply units of type PELV or SELV only.
4. Applicable standards:

VDE 0170/0171 Part 16,	DIN EN 60079-15: 2004-5
VDE 0165 Part 1,	DIN EN 60079-14: 1998-08

Pay particular attention to the following sections:

DIN EN 60079-15:

Chapter 5	Design
Chapter 6	Terminals and cabling
Chapter 7	Air and creeping distances
Chapter 14	Connectors

DIN EN 60079-14:

Chapter 5.2.3	Equipment for use in zone 2
Chapter 9.3	Cabling for zones 1 and 2
Chapter 12.2	Equipment for zones 1 and 2

The controller is additionally equipped with the label represented below:

HIMA

Paul Hildebrandt GmbH + Co KG
A.-Bassermann-Straße 28, D-68782 Brühl

HIMatrix

Ex II 3 G EEx nA II T4 X

F35

0 °C ≤ Ta ≤ 60 °C

Special conditions X must be regarded!

Figure 10: Label for Ex Conditions

4.2 Configuration

The controller can be configured using a programming tool, SILworX or ELOP II Factory. Which programming tool should be used, depends on the revision status of the operating system (firmware):

- ELOP II Factory is required for operating system versions prior to 7.
- SILworX is required for operating system version 7 and beyond.

i

ELOP II Factory is required to load a new operating system (version 7 or beyond) into a controller with a CPU operating system version prior to 7. SILworX is then required once the loading procedure is completed.

4.3 Configuring the Controller with SILworX

In the Hardware Editor, the controller is represented like a base plate equipped with the following modules:

- Processor module (CPU)
- Communication module (COM)
- Output module (DO 8)
- Counter module (HSC 2)
- Input module (MI 24/8)

Double-click the module to open the Detail View with the corresponding tabs. The tabs are used to assign the global variables configured in the user program to the system variables of the corresponding module.

4.3.1 Parameters and Error Codes for the Inputs and Output

The following tables specify the system parameters that can be read and set for the inputs and outputs, including the corresponding error codes.

In the user program, the error codes can be read using the variables assigned within the logic.

The error codes can also be displayed in SILworX.

4 Start-Up**F35****4.3.2 Digital Outputs F35**

The following tables present the statuses and parameters for the output module (DO 8) in the same order as given in the Hardware Editor.

4.3.2.1 Module Tab

The **Module** tab contains the following system parameters.

System parameter	Data type	R/W	Description	
DO.Error Code	WORD	R	Error codes for all digital outputs	
			Coding	Description
			0x0001	Fault within the digital outputs
			0x0002	MOT test of safety switch 1 returns a fault
			0x0004	MOT test of safety switch 2 returns a fault
			0x0008	FTT test of test pattern faulty
			0x0010	MOT test of output switch test pattern faulty
			0x0020	MOT test of output switch test pattern (shutdown test of the outputs) faulty
			0x0040	MOT test active shutdown via WD faulty
			0x0200	All outputs are switched off, total current exceeded
			0x0400	FTT test: 1st temperature threshold exceeded
			0x0800	FTT test: 2nd temperature threshold exceeded
			0x1000	FTT test: Monitoring of auxiliary voltage 1: Low voltage
Module.Error Code	WORD	R	Module error code	
			Coding	Description
			0x0000	I/O processing, if required with errors, see other error codes
			0x0001	No I/O processing (CPU not in RUN)
			0x0002	No I/O processing during the booting test
			0x0004	Manufacturer interface operating
			0x0010	No I/O processing: incorrect configuration
			0x0020	No I/O processing: fault rate exceeded
0x0040/ 0x0080	No I/O processing: configured module not plugged in			
Module SRS	UDINT	R	Slot number (System Rack Slot)	
Module Type	UINT	R	Type of module, target value: 0x00B4 [180 _{dec}]	

Table 38: SILworX - System Parameters for the Digital Outputs, **Module** Tab

4.3.2.2 **DO 8: Channels Tab**

The **DO 8: Channels** tab contains the following system parameters.

System parameter	Data type	R/W	Description										
Channel no.	---	R	Channel number, defined by default										
-> Error Code [BYTE]	BYTE	R	Error codes for the digital output channels <table border="1" data-bbox="710 510 1433 725"> <thead> <tr> <th>Coding</th> <th>Description</th> </tr> </thead> <tbody> <tr> <td>0x01</td> <td>Fault in the digital output module</td> </tr> <tr> <td>0x02</td> <td>Channel shutdown due to overload</td> </tr> <tr> <td>0x04</td> <td>Error while reading back the digital outputs</td> </tr> <tr> <td>0x08</td> <td>Error while reading back the status of the digital outputs</td> </tr> </tbody> </table>	Coding	Description	0x01	Fault in the digital output module	0x02	Channel shutdown due to overload	0x04	Error while reading back the digital outputs	0x08	Error while reading back the status of the digital outputs
Coding	Description												
0x01	Fault in the digital output module												
0x02	Channel shutdown due to overload												
0x04	Error while reading back the digital outputs												
0x08	Error while reading back the status of the digital outputs												
Value [BOOL] ->	BOOL	W	Output value for DO channels: 1 = output energized 0 = output de-energized										

Table 39: SILworX - System Parameters for the Digital Outputs, **DO 8: Channels Tab**

4 Start-Up**F35****4.3.3 Counter F35**

The following table presents the statuses and parameters for the counter module (HSC 2) in the same order given in the SILworX Hardware Editor.

4.3.3.1 Module Tab

The **Module** tab contains the following system parameters.

System parameter	Data type	R/W	Description																						
Counter.Error Code	WORD	R	Counter module error code																						
			<table border="1"> <thead> <tr> <th>Coding</th> <th>Description</th> </tr> </thead> <tbody> <tr> <td>0x0001</td> <td>Fault within the digital outputs</td> </tr> <tr> <td>0x0002</td> <td>Error while comparing the time base</td> </tr> <tr> <td>0x0004</td> <td>Address error while reading the time base</td> </tr> <tr> <td>0x0008</td> <td>Parameters for the time base faulty</td> </tr> <tr> <td>0x0010</td> <td>Address error while reading the counter reading</td> </tr> <tr> <td>0x0020</td> <td>Counter configuration corrupted</td> </tr> <tr> <td>0x0040</td> <td>Address error while reading the Gray code</td> </tr> <tr> <td>0x0080</td> <td>FTT test of test pattern faulty</td> </tr> <tr> <td>0x0100</td> <td>FTT test, error while verifying the coefficients</td> </tr> <tr> <td>0x0200</td> <td>Fault during the initial module configuration</td> </tr> </tbody> </table>	Coding	Description	0x0001	Fault within the digital outputs	0x0002	Error while comparing the time base	0x0004	Address error while reading the time base	0x0008	Parameters for the time base faulty	0x0010	Address error while reading the counter reading	0x0020	Counter configuration corrupted	0x0040	Address error while reading the Gray code	0x0080	FTT test of test pattern faulty	0x0100	FTT test, error while verifying the coefficients	0x0200	Fault during the initial module configuration
			Coding	Description																					
			0x0001	Fault within the digital outputs																					
			0x0002	Error while comparing the time base																					
			0x0004	Address error while reading the time base																					
			0x0008	Parameters for the time base faulty																					
			0x0010	Address error while reading the counter reading																					
			0x0020	Counter configuration corrupted																					
			0x0040	Address error while reading the Gray code																					
			0x0080	FTT test of test pattern faulty																					
0x0100	FTT test, error while verifying the coefficients																								
0x0200	Fault during the initial module configuration																								
Counter[0x].5/24V Mode	BOOL	R/W	Counter input 5 V or 24 V TRUE: 24 V FALSE: 5 V																						
Counter[0x].Auto. Advance Sense	BOOL	R/W	Automatic count direction recognition TRUE: Automatic recognition On FALSE: Manual setting of count direction																						
Counter[0x].Direction	BOOL	R/W	Count direction of the counter (only if <i>Counter[0x].Auto. Advance Sense</i> = FALSE) TRUE: Downwards (decrement) FALSE: Upwards (increment)																						
Counter[0x].Error Code	BYTE	R	Error code of counter channels 1 and 2																						
			<table border="1"> <thead> <tr> <th>Coding</th> <th>Description</th> </tr> </thead> <tbody> <tr> <td>0x01</td> <td>Error in counter module</td> </tr> <tr> <td>0x02</td> <td>Error while comparing the counter readings</td> </tr> <tr> <td>0x04</td> <td>Error while comparing the counter timestamp</td> </tr> <tr> <td>0x08</td> <td>Error while setting the parameters (reset)</td> </tr> </tbody> </table>	Coding	Description	0x01	Error in counter module	0x02	Error while comparing the counter readings	0x04	Error while comparing the counter timestamp	0x08	Error while setting the parameters (reset)												
			Coding	Description																					
			0x01	Error in counter module																					
			0x02	Error while comparing the counter readings																					
0x04	Error while comparing the counter timestamp																								
0x08	Error while setting the parameters (reset)																								
Counter[0x].Gray Code	BOOL	R/W	Decoder / pulse operation TRUE: Gray code decoder FALSE: Pulse operation																						
Counter[0x].Reset	BOOL	R/W	Counter reset TRUE: No reset FALSE: Reset																						
Counter[0x].Time Overflow	BOOL	R	Overflow indication for the timestamp of the counters TRUE: 24-bit overflow since last measurement FALSE: No 24-bit overflow since last measurement																						
Counter[0x].Timestamp	UDINT	R	Timestamp for <i>Counter[0x].Value</i> 24 bits, time resolution 1 µs time resolution																						
Counter[0x].Value	UDINT	R	Counter reading: 24 bits for pulse counter, 3 bits for Gray code																						

F35

4 Start-Up

System parameter	Data type	R/W	Description																
Counter[0x].Value Overflow	BOOL	R	Counter overflow indication TRUE: 24- bit overflow since last cycle (only if <i>Counter[0x].Auto. Advance Sense = FALSE</i>) FALSE: No overflow since last cycle																
Module Error Code	WORD	R	Module error code																
			<table border="1"> <thead> <tr> <th>Coding</th> <th>Description</th> </tr> </thead> <tbody> <tr> <td>0x0000</td> <td>I/O processing, if required with errors, see other error codes</td> </tr> <tr> <td>0x0001</td> <td>No I/O processing (CPU not in RUN)</td> </tr> <tr> <td>0x0002</td> <td>No I/O processing during the booting test</td> </tr> <tr> <td>0x0004</td> <td>Manufacturer interface operating</td> </tr> <tr> <td>0x0010</td> <td>No I/O processing: incorrect configuration</td> </tr> <tr> <td>0x0020</td> <td>No I/O processing: fault rate exceeded</td> </tr> <tr> <td>0x0040/ 0x0080</td> <td>No I/O processing: configured module not plugged in</td> </tr> </tbody> </table>	Coding	Description	0x0000	I/O processing, if required with errors, see other error codes	0x0001	No I/O processing (CPU not in RUN)	0x0002	No I/O processing during the booting test	0x0004	Manufacturer interface operating	0x0010	No I/O processing: incorrect configuration	0x0020	No I/O processing: fault rate exceeded	0x0040/ 0x0080	No I/O processing: configured module not plugged in
			Coding	Description															
			0x0000	I/O processing, if required with errors, see other error codes															
			0x0001	No I/O processing (CPU not in RUN)															
			0x0002	No I/O processing during the booting test															
			0x0004	Manufacturer interface operating															
			0x0010	No I/O processing: incorrect configuration															
0x0020	No I/O processing: fault rate exceeded																		
0x0040/ 0x0080	No I/O processing: configured module not plugged in																		
Module SRS	UDINT	R	Slot number (System Rack Slot)																
Module Type	UINT	R	Type of module, target value: 0x0003 [3 _{dec}]																

Table 40: SILworX - System Parameters for the Counters, **Module** Tab

4 Start-Up**F35****4.3.4 Analog and Digital Inputs F35**

The following tables present the statuses and parameters for the analog and digital input module (MI 24/8) in the same order as given in the Hardware Editor.

4.3.4.1 Module Tab

The **Module** tab contains the following system parameters.

System parameter	R/W	Description																													
Enter these parameters directly in the Hardware Editor.																															
FS 1000 / FS 2000	W	Resolution of the -> <i>Value [INT]</i> parameter for the analog input channels. FS 1000: 0...1000 (0..10 V) FS 2000: 0...2000 (0...10 V)																													
System parameter	Data type	R/W	Description																												
AI.Error Code	WORD	R	Error codes for all analog and digital outputs <table border="1"> <thead> <tr> <th>Coding</th> <th>Description</th> </tr> </thead> <tbody> <tr> <td>0x0001</td> <td>Module fault.</td> </tr> <tr> <td>0x0004</td> <td>MOT test: Time monitoring of conversion</td> </tr> <tr> <td>0x0008</td> <td>FTT test: Walking bit of data bus faulty</td> </tr> <tr> <td>0x0010</td> <td>FTT test: Error while checking the coefficients</td> </tr> <tr> <td>0x0020</td> <td>FTT test: Operating voltages faulty</td> </tr> <tr> <td>0x0040</td> <td>A/D conversion faulty (DRDY_LOW)</td> </tr> <tr> <td>0x0080</td> <td>MOT test: Cross links of MUX faulty</td> </tr> <tr> <td>0x0100</td> <td>MOT test: Walking bit of data bus faulty</td> </tr> <tr> <td>0x0200</td> <td>MOT test: Multiplexer addresses faulty</td> </tr> <tr> <td>0x0400</td> <td>MOT test: Operating voltages faulty</td> </tr> <tr> <td>0x0800</td> <td>MOT test: Measuring system (characteristic) faulty (unipolar)</td> </tr> <tr> <td>0x1000</td> <td>MOT test: Measuring system (final values, zero point) faulty (unipolar)</td> </tr> <tr> <td>0x8000</td> <td>A/D conversion faulty (DRDY_HIGH)</td> </tr> </tbody> </table>	Coding	Description	0x0001	Module fault.	0x0004	MOT test: Time monitoring of conversion	0x0008	FTT test: Walking bit of data bus faulty	0x0010	FTT test: Error while checking the coefficients	0x0020	FTT test: Operating voltages faulty	0x0040	A/D conversion faulty (DRDY_LOW)	0x0080	MOT test: Cross links of MUX faulty	0x0100	MOT test: Walking bit of data bus faulty	0x0200	MOT test: Multiplexer addresses faulty	0x0400	MOT test: Operating voltages faulty	0x0800	MOT test: Measuring system (characteristic) faulty (unipolar)	0x1000	MOT test: Measuring system (final values, zero point) faulty (unipolar)	0x8000	A/D conversion faulty (DRDY_HIGH)
Coding	Description																														
0x0001	Module fault.																														
0x0004	MOT test: Time monitoring of conversion																														
0x0008	FTT test: Walking bit of data bus faulty																														
0x0010	FTT test: Error while checking the coefficients																														
0x0020	FTT test: Operating voltages faulty																														
0x0040	A/D conversion faulty (DRDY_LOW)																														
0x0080	MOT test: Cross links of MUX faulty																														
0x0100	MOT test: Walking bit of data bus faulty																														
0x0200	MOT test: Multiplexer addresses faulty																														
0x0400	MOT test: Operating voltages faulty																														
0x0800	MOT test: Measuring system (characteristic) faulty (unipolar)																														
0x1000	MOT test: Measuring system (final values, zero point) faulty (unipolar)																														
0x8000	A/D conversion faulty (DRDY_HIGH)																														
Module.Error Code	WORD	R	Module error code <table border="1"> <thead> <tr> <th>Coding</th> <th>Description</th> </tr> </thead> <tbody> <tr> <td>0x0000</td> <td>I/O processing, if required with errors, see other error codes</td> </tr> <tr> <td>0x0001</td> <td>No I/O processing (CPU not in RUN)</td> </tr> <tr> <td>0x0002</td> <td>No I/O processing during the booting test</td> </tr> <tr> <td>0x0004</td> <td>Manufacturer interface operating</td> </tr> <tr> <td>0x0010</td> <td>No I/O processing: incorrect configuration</td> </tr> <tr> <td>0x0020</td> <td>No I/O processing: fault rate exceeded</td> </tr> <tr> <td>0x0040/ 0x0080</td> <td>No I/O processing: configured module not plugged in</td> </tr> </tbody> </table>	Coding	Description	0x0000	I/O processing, if required with errors, see other error codes	0x0001	No I/O processing (CPU not in RUN)	0x0002	No I/O processing during the booting test	0x0004	Manufacturer interface operating	0x0010	No I/O processing: incorrect configuration	0x0020	No I/O processing: fault rate exceeded	0x0040/ 0x0080	No I/O processing: configured module not plugged in												
Coding	Description																														
0x0000	I/O processing, if required with errors, see other error codes																														
0x0001	No I/O processing (CPU not in RUN)																														
0x0002	No I/O processing during the booting test																														
0x0004	Manufacturer interface operating																														
0x0010	No I/O processing: incorrect configuration																														
0x0020	No I/O processing: fault rate exceeded																														
0x0040/ 0x0080	No I/O processing: configured module not plugged in																														
Module SRS	UDINT	R	Slot number (System Rack Slot)																												
Module Type	UINT	R	Type of module, target value: 0x00D2 [210 _{dec}] (FS 1000) 0x0096 [150 _{dec}] (FS 2000)																												

Table 41: SILworX - System Parameters for the Digital Inputs, **Module** Tab

F35

4 Start-Up

4.3.4.2 MI 24/8 FS 1000: AI Channels Tab

The **MI 24/8 FS1000: AI Channels** tab contains the following system parameters.

System parameter	Data type	R/W	Description																		
Channel no.	---	R	Channel number, defined by default																		
-> Error Code [BYTE]	BYTE	R	Error codes for the analog input channels (1...8) <table border="1" data-bbox="715 539 1434 936"> <thead> <tr> <th>Coding</th> <th>Description</th> </tr> </thead> <tbody> <tr> <td>0x01</td> <td>Fault in the analog input module</td> </tr> <tr> <td>0x02</td> <td>Not used</td> </tr> <tr> <td>0x04</td> <td>A/D converter faulty, measured values invalid</td> </tr> <tr> <td>0x08</td> <td>Measured value out of the safety-related accuracy</td> </tr> <tr> <td>0x10</td> <td>Measured value overflow</td> </tr> <tr> <td>0x20</td> <td>Channel not operating</td> </tr> <tr> <td>0x40</td> <td>Address error of both A/D converters</td> </tr> <tr> <td>0x80</td> <td>Configuration of the hysteresis faulty</td> </tr> </tbody> </table>	Coding	Description	0x01	Fault in the analog input module	0x02	Not used	0x04	A/D converter faulty, measured values invalid	0x08	Measured value out of the safety-related accuracy	0x10	Measured value overflow	0x20	Channel not operating	0x40	Address error of both A/D converters	0x80	Configuration of the hysteresis faulty
Coding	Description																				
0x01	Fault in the analog input module																				
0x02	Not used																				
0x04	A/D converter faulty, measured values invalid																				
0x08	Measured value out of the safety-related accuracy																				
0x10	Measured value overflow																				
0x20	Channel not operating																				
0x40	Address error of both A/D converters																				
0x80	Configuration of the hysteresis faulty																				
-> Value [INT]	INT	R	Analog value of the AI channels (1...8) [INT] from 0...1000 (variant: FS 1000), 0...2000 (variant: FS 2000) (0 V...+10 V) The validity depends on the <i>AI.Error Code</i> .																		
Channel Used [BOOL] ->	BOOL	W	Configuration of the channels 1...8: 1 = Channel operating 0 = Channel not operating																		

Table 42: SILworX - System Parameters for the Inputs, **MI 24/8 FS1000: AI Channels** Tab

4 Start-Up

F35

4.3.4.3 MI 24/8 FS1000: DI Channels Tab

The **MI 24/8 FS1000: DI Channels** tab contains the following system parameters.

System parameter	Data type	R/W	Description																		
Channel no.	---	R	Channel number, defined by default																		
-> Error Code [BYTE]	BYTE	R	Error codes for the digital input channels (1...24). <table border="1" data-bbox="662 539 1380 936"> <thead> <tr> <th>Coding</th> <th>Description</th> </tr> </thead> <tbody> <tr> <td>0x01</td> <td>Fault in the digital input module</td> </tr> <tr> <td>0x02</td> <td>Not used</td> </tr> <tr> <td>0x04</td> <td>A/D converter faulty, measured values invalid</td> </tr> <tr> <td>0x08</td> <td>Measured value out of the safety-related accuracy</td> </tr> <tr> <td>0x10</td> <td>Measured value overflow</td> </tr> <tr> <td>0x20</td> <td>Channel not operating</td> </tr> <tr> <td>0x40</td> <td>Address error of both A/D converters</td> </tr> <tr> <td>0x80</td> <td>Configuration of the hysteresis faulty</td> </tr> </tbody> </table>	Coding	Description	0x01	Fault in the digital input module	0x02	Not used	0x04	A/D converter faulty, measured values invalid	0x08	Measured value out of the safety-related accuracy	0x10	Measured value overflow	0x20	Channel not operating	0x40	Address error of both A/D converters	0x80	Configuration of the hysteresis faulty
Coding	Description																				
0x01	Fault in the digital input module																				
0x02	Not used																				
0x04	A/D converter faulty, measured values invalid																				
0x08	Measured value out of the safety-related accuracy																				
0x10	Measured value overflow																				
0x20	Channel not operating																				
0x40	Address error of both A/D converters																				
0x80	Configuration of the hysteresis faulty																				
-> Value [BOOL]	BOOL	R	Analog value of the DI channels (1...24) [BOOL] in accordance with the hysteresis. The validity depends on -> <i>Error Code [BYTE]</i> .																		
-> Value - analog [int]	INT	R	Analog value of the DI channels (1...24) [INT] from 0...3000 (0...30 V). The validity depends on -> <i>Error Code [BYTE]</i> .																		
Channel Used [BOOL] ->	BOOL	W	Configuration of channels 1...24: 1 = Channel operating 0 = Channel not operating																		
Hysteresis LOW [INT] ->	INT	W	Upper limit of the low level voltage range -> <i>Value [BOOL]</i>																		
Hysteresis HIGH [INT] ->	INT	W	Lower limit of the high level voltage range -> <i>Value [BOOL]</i>																		

Table 43: SILworX - System Parameters for the Digital Inputs, **MI 24/8 FS1000: DI Channels** Tab

4.4 Configuring a Controller Using ELOP II Factory

4.4.1 Configuring the Inputs and Outputs

The signals previously defined in the Signal Editor (Hardware Management) are assigned to the individual channels (inputs and outputs) using ELOP II Factory. Refer to the System Manual for Compact Systems or the online help for more details.

The following chapter describes the system signals used for assigning signals in the controller.

4.4.2 Signals and Error Codes for the Inputs and Outputs

The following tables specify the system signals that can be read and set for the inputs and outputs, including the corresponding error codes.

In the user program, the error codes can be read using the signals assigned within the logic.

The error codes can also be displayed in ELOP II Factory.

4 Start-Up**F35****4.4.3 Digital Inputs F35**

System Signal	R/W	Description																												
Mod.SRS [UDINT]	R	Slot number (System Rack Slot)																												
Mod. Type [UINT]	R	Type of module, target value: 0x00D2 [210 _{dec}] (FS 1000) 0x0096 [150 _{dec}] (FS 2000)																												
Mod. Error Code [WORD]	R	Error codes for the module <table border="1"> <thead> <tr> <th>Coding</th> <th>Description</th> </tr> </thead> <tbody> <tr> <td>0x0000</td> <td>I/O processing, if required with errors see other error codes</td> </tr> <tr> <td>0x0001</td> <td>No I/O processing (CPU not in RUN)</td> </tr> <tr> <td>0x0002</td> <td>No I/O processing during the booting test</td> </tr> <tr> <td>0x0004</td> <td>Manufacturer interface operating</td> </tr> <tr> <td>0x0010</td> <td>No I/O processing: wrong configuration</td> </tr> <tr> <td>0x0020</td> <td>No I/O processing: fault rate exceeded</td> </tr> <tr> <td>0x0040/ 0x0080</td> <td>No I/O processing: configured module not plugged in</td> </tr> </tbody> </table>	Coding	Description	0x0000	I/O processing, if required with errors see other error codes	0x0001	No I/O processing (CPU not in RUN)	0x0002	No I/O processing during the booting test	0x0004	Manufacturer interface operating	0x0010	No I/O processing: wrong configuration	0x0020	No I/O processing: fault rate exceeded	0x0040/ 0x0080	No I/O processing: configured module not plugged in												
Coding	Description																													
0x0000	I/O processing, if required with errors see other error codes																													
0x0001	No I/O processing (CPU not in RUN)																													
0x0002	No I/O processing during the booting test																													
0x0004	Manufacturer interface operating																													
0x0010	No I/O processing: wrong configuration																													
0x0020	No I/O processing: fault rate exceeded																													
0x0040/ 0x0080	No I/O processing: configured module not plugged in																													
AI.Error Code [WORD]	R	Error codes for all analog and digital inputs <table border="1"> <thead> <tr> <th>Coding</th> <th>Description</th> </tr> </thead> <tbody> <tr> <td>0x0001</td> <td>Module fault.</td> </tr> <tr> <td>0x0004</td> <td>MOT test: Time monitoring of conversion</td> </tr> <tr> <td>0x0008</td> <td>FTT test: Walking bit of data bus faulty</td> </tr> <tr> <td>0x0010</td> <td>FTT test: Error while checking the coefficients</td> </tr> <tr> <td>0x0020</td> <td>FTT test: Operating voltages faulty</td> </tr> <tr> <td>0x0040</td> <td>A/D conversion faulty (DRDY_LOW)</td> </tr> <tr> <td>0x0080</td> <td>MOT test: Cross links of MUX faulty</td> </tr> <tr> <td>0x0100</td> <td>MOT test: Walking bit of data bus faulty</td> </tr> <tr> <td>0x0200</td> <td>MOT test: Multiplexer addresses faulty</td> </tr> <tr> <td>0x0400</td> <td>MOT test: Operating voltages faulty</td> </tr> <tr> <td>0x0800</td> <td>MOT test: Measuring system (characteristic) faulty (unipolar)</td> </tr> <tr> <td>0x1000</td> <td>MOT test: Measuring system (final values, zero point) faulty (unipolar)</td> </tr> <tr> <td>0x8000</td> <td>A/D conversion faulty (DRDY_HIGH)</td> </tr> </tbody> </table>	Coding	Description	0x0001	Module fault.	0x0004	MOT test: Time monitoring of conversion	0x0008	FTT test: Walking bit of data bus faulty	0x0010	FTT test: Error while checking the coefficients	0x0020	FTT test: Operating voltages faulty	0x0040	A/D conversion faulty (DRDY_LOW)	0x0080	MOT test: Cross links of MUX faulty	0x0100	MOT test: Walking bit of data bus faulty	0x0200	MOT test: Multiplexer addresses faulty	0x0400	MOT test: Operating voltages faulty	0x0800	MOT test: Measuring system (characteristic) faulty (unipolar)	0x1000	MOT test: Measuring system (final values, zero point) faulty (unipolar)	0x8000	A/D conversion faulty (DRDY_HIGH)
Coding	Description																													
0x0001	Module fault.																													
0x0004	MOT test: Time monitoring of conversion																													
0x0008	FTT test: Walking bit of data bus faulty																													
0x0010	FTT test: Error while checking the coefficients																													
0x0020	FTT test: Operating voltages faulty																													
0x0040	A/D conversion faulty (DRDY_LOW)																													
0x0080	MOT test: Cross links of MUX faulty																													
0x0100	MOT test: Walking bit of data bus faulty																													
0x0200	MOT test: Multiplexer addresses faulty																													
0x0400	MOT test: Operating voltages faulty																													
0x0800	MOT test: Measuring system (characteristic) faulty (unipolar)																													
0x1000	MOT test: Measuring system (final values, zero point) faulty (unipolar)																													
0x8000	A/D conversion faulty (DRDY_HIGH)																													
DI[xx].Error Code [BYTE]	R	Error codes for the digital input channels (1...24) <table border="1"> <thead> <tr> <th>Coding</th> <th>Description</th> </tr> </thead> <tbody> <tr> <td>0x01</td> <td>Fault in the digital input module</td> </tr> <tr> <td>0x02</td> <td>CPU operating system versions prior to 4: measured values invalid, CPU operating system version 4 and beyond: not used</td> </tr> <tr> <td>0x04</td> <td>A/D converter faulty, measured values invalid CPU operating system version 4 and beyond: Measured values invalid</td> </tr> <tr> <td>0x08</td> <td>Measured value out of the safety-related accuracy</td> </tr> <tr> <td>0x10</td> <td>Measured value overflow</td> </tr> <tr> <td>0x20</td> <td>Channel not operating</td> </tr> <tr> <td>0x40</td> <td>Address error of both A/D converters</td> </tr> <tr> <td>0x80</td> <td>Configuration of the hysteresis faulty</td> </tr> </tbody> </table>	Coding	Description	0x01	Fault in the digital input module	0x02	CPU operating system versions prior to 4: measured values invalid, CPU operating system version 4 and beyond: not used	0x04	A/D converter faulty, measured values invalid CPU operating system version 4 and beyond: Measured values invalid	0x08	Measured value out of the safety-related accuracy	0x10	Measured value overflow	0x20	Channel not operating	0x40	Address error of both A/D converters	0x80	Configuration of the hysteresis faulty										
Coding	Description																													
0x01	Fault in the digital input module																													
0x02	CPU operating system versions prior to 4: measured values invalid, CPU operating system version 4 and beyond: not used																													
0x04	A/D converter faulty, measured values invalid CPU operating system version 4 and beyond: Measured values invalid																													
0x08	Measured value out of the safety-related accuracy																													
0x10	Measured value overflow																													
0x20	Channel not operating																													
0x40	Address error of both A/D converters																													
0x80	Configuration of the hysteresis faulty																													
DI[xx].Value Analog [INT]	R	Analog value of the DI channels (1...24) [INT] from 0...3000 (0...30 V) The validity depends on DI[xx].Error Code																												

F35

4 Start-Up

System Signal	R/W	Description
DI[xx].Value [BOOL]	R	Analog value of the DI channels (1...24) [BOOL] in accordance with hysteresis The validity depends on <i>DI[xx].Error Code</i>
DI[xx].Hysteresis LOW [INT]	W	Upper limit of the low level voltage range <i>DI[xx].Value</i>
DI[xx].Hysteresis HIGH [INT]	W	Low limit of the high level voltage range <i>DI[xx].Value</i>
DI[xx].Used [BOOL]	W	Configuration of channels 1...24: 1 = Channel operating 0 = Channel not operating

Table 44: ELOP II Factory - Digital Input System Signals

4 Start-Up**F35****4.4.4 Analog Inputs F35**

System Signal	R/W	Description																												
Mod.SRS [UDINT]	R	Slot number (System Rack Slot)																												
Mod. Type [UINT]	R	Type of module, target value: 0x00D2 [210 _{dec}] (FS 1000) 0x0096 [150 _{dec}] (FS 2000)																												
Mod. Error Code [WORD]	R	Error codes for the module <table border="1"> <thead> <tr> <th>Coding</th> <th>Description</th> </tr> </thead> <tbody> <tr> <td>0x0000</td> <td>I/O processing, if required with errors, see other error codes</td> </tr> <tr> <td>0x0001</td> <td>No I/O processing (CPU not in RUN)</td> </tr> <tr> <td>0x0002</td> <td>No I/O processing during the booting test</td> </tr> <tr> <td>0x0004</td> <td>Manufacturer interface operating</td> </tr> <tr> <td>0x0010</td> <td>No I/O processing: incorrect configuration</td> </tr> <tr> <td>0x0020</td> <td>No I/O processing: fault rate exceeded</td> </tr> <tr> <td>0x0040/ 0x0080</td> <td>No I/O processing: configured module not plugged in</td> </tr> </tbody> </table>	Coding	Description	0x0000	I/O processing, if required with errors, see other error codes	0x0001	No I/O processing (CPU not in RUN)	0x0002	No I/O processing during the booting test	0x0004	Manufacturer interface operating	0x0010	No I/O processing: incorrect configuration	0x0020	No I/O processing: fault rate exceeded	0x0040/ 0x0080	No I/O processing: configured module not plugged in												
		Coding	Description																											
		0x0000	I/O processing, if required with errors, see other error codes																											
		0x0001	No I/O processing (CPU not in RUN)																											
		0x0002	No I/O processing during the booting test																											
		0x0004	Manufacturer interface operating																											
		0x0010	No I/O processing: incorrect configuration																											
		0x0020	No I/O processing: fault rate exceeded																											
		0x0040/ 0x0080	No I/O processing: configured module not plugged in																											
AI.Error code [WORD]	R	Error codes for all analog and digital inputs <table border="1"> <thead> <tr> <th>Coding</th> <th>Description</th> </tr> </thead> <tbody> <tr> <td>0x0001</td> <td>Module fault.</td> </tr> <tr> <td>0x0004</td> <td>MOT test: time monitoring of conversion</td> </tr> <tr> <td>0x0008</td> <td>FTT test: Walking bit of data bus faulty</td> </tr> <tr> <td>0x0010</td> <td>FTT test: Error while checking coefficients</td> </tr> <tr> <td>0x0020</td> <td>FTT test: Operating voltages faulty</td> </tr> <tr> <td>0x0040</td> <td>A/D conversion faulty (DRDY_LOW)</td> </tr> <tr> <td>0x0080</td> <td>MOT test: Cross links of MUX faulty</td> </tr> <tr> <td>0x0100</td> <td>MOT test: Walking bit of data bus faulty</td> </tr> <tr> <td>0x0200</td> <td>MOT test: Multiplexer addresses faulty</td> </tr> <tr> <td>0x0400</td> <td>MOT test: Operating voltages faulty</td> </tr> <tr> <td>0x0800</td> <td>MOT test: Measuring system (characteristic) faulty (unipolar)</td> </tr> <tr> <td>0x1000</td> <td>MOT test: Measuring system (final values, zero point) faulty (unipolar)</td> </tr> <tr> <td>0x8000</td> <td>A/D conversion faulty (DRDY_HIGH)</td> </tr> </tbody> </table>	Coding	Description	0x0001	Module fault.	0x0004	MOT test: time monitoring of conversion	0x0008	FTT test: Walking bit of data bus faulty	0x0010	FTT test: Error while checking coefficients	0x0020	FTT test: Operating voltages faulty	0x0040	A/D conversion faulty (DRDY_LOW)	0x0080	MOT test: Cross links of MUX faulty	0x0100	MOT test: Walking bit of data bus faulty	0x0200	MOT test: Multiplexer addresses faulty	0x0400	MOT test: Operating voltages faulty	0x0800	MOT test: Measuring system (characteristic) faulty (unipolar)	0x1000	MOT test: Measuring system (final values, zero point) faulty (unipolar)	0x8000	A/D conversion faulty (DRDY_HIGH)
		Coding	Description																											
		0x0001	Module fault.																											
		0x0004	MOT test: time monitoring of conversion																											
		0x0008	FTT test: Walking bit of data bus faulty																											
		0x0010	FTT test: Error while checking coefficients																											
		0x0020	FTT test: Operating voltages faulty																											
		0x0040	A/D conversion faulty (DRDY_LOW)																											
		0x0080	MOT test: Cross links of MUX faulty																											
		0x0100	MOT test: Walking bit of data bus faulty																											
		0x0200	MOT test: Multiplexer addresses faulty																											
		0x0400	MOT test: Operating voltages faulty																											
		0x0800	MOT test: Measuring system (characteristic) faulty (unipolar)																											
		0x1000	MOT test: Measuring system (final values, zero point) faulty (unipolar)																											
0x8000	A/D conversion faulty (DRDY_HIGH)																													
AI[xx].Error Code [BYTE]	R	Error codes for the analog input channels (1...8) <table border="1"> <thead> <tr> <th>Coding</th> <th>Description</th> </tr> </thead> <tbody> <tr> <td>0x01</td> <td>Fault in the analog input module</td> </tr> <tr> <td>0x02</td> <td>CPU operating system versions prior to 4: measured values invalid, CPU operating system version 4 and beyond: not used</td> </tr> <tr> <td>0x04</td> <td>A/D converter faulty, measured values invalid CPU operating system version 4 and beyond: Measured values invalid</td> </tr> <tr> <td>0x08</td> <td>Measured value out of the safety-related accuracy</td> </tr> <tr> <td>0x10</td> <td>Measured value overflow</td> </tr> <tr> <td>0x20</td> <td>Channel not operating</td> </tr> <tr> <td>0x40</td> <td>Address error of both A/D converters</td> </tr> <tr> <td>0x80</td> <td>Configuration of the hysteresis faulty</td> </tr> </tbody> </table>	Coding	Description	0x01	Fault in the analog input module	0x02	CPU operating system versions prior to 4: measured values invalid, CPU operating system version 4 and beyond: not used	0x04	A/D converter faulty, measured values invalid CPU operating system version 4 and beyond: Measured values invalid	0x08	Measured value out of the safety-related accuracy	0x10	Measured value overflow	0x20	Channel not operating	0x40	Address error of both A/D converters	0x80	Configuration of the hysteresis faulty										
		Coding	Description																											
		0x01	Fault in the analog input module																											
		0x02	CPU operating system versions prior to 4: measured values invalid, CPU operating system version 4 and beyond: not used																											
		0x04	A/D converter faulty, measured values invalid CPU operating system version 4 and beyond: Measured values invalid																											
		0x08	Measured value out of the safety-related accuracy																											
		0x10	Measured value overflow																											
		0x20	Channel not operating																											
		0x40	Address error of both A/D converters																											
0x80	Configuration of the hysteresis faulty																													

F35**4 Start-Up**

System Signal	R/W	Description
AI[xx].Value [INT]	R	Analog value of the AI channels (1...8) [INT] from 0...1000 (variant: FS 1000), 0...2000 (variant: FS 2000) (0 V...+10 V) The validity depends on <i>AI[xx].Error Code</i> .
AI[0x].Used [BOOL]	W	Configuration of the channels 1...8: 1 = Channel operating 0 = Channel not operating

Table 45: ELOP II Factory - Analog Input System Signals

4 Start-Up

F35

4.4.5 Digital Outputs F35

System Signal	R/W	Description																								
Mod.SRS [UDINT]	R	Slot number (System Rack Slot)																								
Mod. Type [UINT]	R	Type of module, target value: 0x00B4 [180 _{dec}]																								
Mod. Error code [WORD]	R	Error codes for the module <table border="1" style="width: 100%; border-collapse: collapse;"> <thead> <tr> <th style="width: 20%;">Coding</th> <th>Description</th> </tr> </thead> <tbody> <tr> <td>0x0000</td> <td>I/O processing, if required with errors, see other error codes</td> </tr> <tr> <td>0x0001</td> <td>No I/O processing (CPU not in RUN)</td> </tr> <tr> <td>0x0002</td> <td>No I/O processing during the booting test</td> </tr> <tr> <td>0x0004</td> <td>Manufacturer interface operating</td> </tr> <tr> <td>0x0010</td> <td>No I/O processing: incorrect configuration</td> </tr> <tr> <td>0x0020</td> <td>No I/O processing: fault rate exceeded</td> </tr> <tr> <td>0x0040/ 0x0080</td> <td>No I/O processing: configured module not plugged in</td> </tr> </tbody> </table>	Coding	Description	0x0000	I/O processing, if required with errors, see other error codes	0x0001	No I/O processing (CPU not in RUN)	0x0002	No I/O processing during the booting test	0x0004	Manufacturer interface operating	0x0010	No I/O processing: incorrect configuration	0x0020	No I/O processing: fault rate exceeded	0x0040/ 0x0080	No I/O processing: configured module not plugged in								
		Coding	Description																							
		0x0000	I/O processing, if required with errors, see other error codes																							
		0x0001	No I/O processing (CPU not in RUN)																							
		0x0002	No I/O processing during the booting test																							
		0x0004	Manufacturer interface operating																							
		0x0010	No I/O processing: incorrect configuration																							
		0x0020	No I/O processing: fault rate exceeded																							
0x0040/ 0x0080	No I/O processing: configured module not plugged in																									
DO.Error Code [WORD]	R	Error codes for all digital outputs <table border="1" style="width: 100%; border-collapse: collapse;"> <thead> <tr> <th style="width: 20%;">Coding</th> <th>Description</th> </tr> </thead> <tbody> <tr> <td>0x0001</td> <td>Fault within the digital outputs</td> </tr> <tr> <td>0x0002</td> <td>MOT test of safety switch 1 returns a fault</td> </tr> <tr> <td>0x0004</td> <td>MOT test of safety switch 2 returns a fault</td> </tr> <tr> <td>0x0008</td> <td>FTT test of test pattern faulty</td> </tr> <tr> <td>0x0010</td> <td>MOT test of output switch test pattern faulty</td> </tr> <tr> <td>0x0020</td> <td>MOT test of output switch test pattern (shutdown test of the outputs) faulty</td> </tr> <tr> <td>0x0040</td> <td>MOT test active shutdown via WD faulty</td> </tr> <tr> <td>0x0200</td> <td>All outputs are switched off, total current exceeded</td> </tr> <tr> <td>0x0400</td> <td>FTT test: 1st temperature threshold exceeded</td> </tr> <tr> <td>0x0800</td> <td>FTT test: 2nd temperature threshold exceeded</td> </tr> <tr> <td>0x1000</td> <td>FTT test: Monitoring of auxiliary voltage 1: Low voltage</td> </tr> </tbody> </table>	Coding	Description	0x0001	Fault within the digital outputs	0x0002	MOT test of safety switch 1 returns a fault	0x0004	MOT test of safety switch 2 returns a fault	0x0008	FTT test of test pattern faulty	0x0010	MOT test of output switch test pattern faulty	0x0020	MOT test of output switch test pattern (shutdown test of the outputs) faulty	0x0040	MOT test active shutdown via WD faulty	0x0200	All outputs are switched off, total current exceeded	0x0400	FTT test: 1st temperature threshold exceeded	0x0800	FTT test: 2nd temperature threshold exceeded	0x1000	FTT test: Monitoring of auxiliary voltage 1: Low voltage
		Coding	Description																							
		0x0001	Fault within the digital outputs																							
		0x0002	MOT test of safety switch 1 returns a fault																							
		0x0004	MOT test of safety switch 2 returns a fault																							
		0x0008	FTT test of test pattern faulty																							
		0x0010	MOT test of output switch test pattern faulty																							
		0x0020	MOT test of output switch test pattern (shutdown test of the outputs) faulty																							
		0x0040	MOT test active shutdown via WD faulty																							
		0x0200	All outputs are switched off, total current exceeded																							
		0x0400	FTT test: 1st temperature threshold exceeded																							
		0x0800	FTT test: 2nd temperature threshold exceeded																							
		0x1000	FTT test: Monitoring of auxiliary voltage 1: Low voltage																							
DO[xx].Error Code [BYTE]	R	Error codes for the digital output channels <table border="1" style="width: 100%; border-collapse: collapse;"> <thead> <tr> <th style="width: 20%;">Coding</th> <th>Description</th> </tr> </thead> <tbody> <tr> <td>0x01</td> <td>Fault in the digital input module</td> </tr> <tr> <td>0x02</td> <td>Channel shutdown due to overload</td> </tr> <tr> <td>0x04</td> <td>Error while reading back the digital outputs</td> </tr> <tr> <td>0x08</td> <td>Error while reading back the status of the digital outputs</td> </tr> </tbody> </table>	Coding	Description	0x01	Fault in the digital input module	0x02	Channel shutdown due to overload	0x04	Error while reading back the digital outputs	0x08	Error while reading back the status of the digital outputs														
		Coding	Description																							
		0x01	Fault in the digital input module																							
		0x02	Channel shutdown due to overload																							
		0x04	Error while reading back the digital outputs																							
0x08	Error while reading back the status of the digital outputs																									
DO[xx].Value [BOOL]	W	Output value for DO channels: 1 = output energized 0 = output de-energized																								

Table 46: ELOP II Factory - Digital Output System Signals

F35

4 Start-Up

4.4.6 Counter F35

System Signal	R/W	Description																						
Mod.SRS [UDINT]	R	Slot number (System Rack Slot)																						
Mod. Type [UINT]	R	Type of module, target value: 0x0003 [3 _{dec}]																						
Mod. Error Code [WORD]	R	Error codes for the module <table border="1"> <thead> <tr> <th>Coding</th> <th>Description</th> </tr> </thead> <tbody> <tr> <td>0x0000</td> <td>I/O processing, if required with errors, see other error codes</td> </tr> <tr> <td>0x0001</td> <td>No I/O processing (CPU not in RUN)</td> </tr> <tr> <td>0x0002</td> <td>No I/O processing during the booting test</td> </tr> <tr> <td>0x0004</td> <td>Manufacturer interface operating</td> </tr> <tr> <td>0x0010</td> <td>No I/O processing: incorrect configuration</td> </tr> <tr> <td>0x0020</td> <td>No I/O processing: fault rate exceeded</td> </tr> <tr> <td>0x0040/ 0x0080</td> <td>No I/O processing: configured module not plugged in</td> </tr> </tbody> </table>	Coding	Description	0x0000	I/O processing, if required with errors, see other error codes	0x0001	No I/O processing (CPU not in RUN)	0x0002	No I/O processing during the booting test	0x0004	Manufacturer interface operating	0x0010	No I/O processing: incorrect configuration	0x0020	No I/O processing: fault rate exceeded	0x0040/ 0x0080	No I/O processing: configured module not plugged in						
Coding	Description																							
0x0000	I/O processing, if required with errors, see other error codes																							
0x0001	No I/O processing (CPU not in RUN)																							
0x0002	No I/O processing during the booting test																							
0x0004	Manufacturer interface operating																							
0x0010	No I/O processing: incorrect configuration																							
0x0020	No I/O processing: fault rate exceeded																							
0x0040/ 0x0080	No I/O processing: configured module not plugged in																							
Counter.Error Code [WORD]	R	Error code for the counter module <table border="1"> <thead> <tr> <th>Coding</th> <th>Description</th> </tr> </thead> <tbody> <tr> <td>0x0001</td> <td>Fault within the digital outputs</td> </tr> <tr> <td>0x0002</td> <td>Error while comparing the time base</td> </tr> <tr> <td>0x0004</td> <td>Address error while reading the time base</td> </tr> <tr> <td>0x0008</td> <td>Parameters for time base faulty</td> </tr> <tr> <td>0x0010</td> <td>Address error while reading the counter reading</td> </tr> <tr> <td>0x0020</td> <td>Counter configuration corrupted</td> </tr> <tr> <td>0x0040</td> <td>Address error while reading the Gray code</td> </tr> <tr> <td>0x0080</td> <td>FTT test of test pattern faulty</td> </tr> <tr> <td>0x0100</td> <td>FTT test - error while checking the coefficients</td> </tr> <tr> <td>0x0200</td> <td>Fault during the initial module configuration</td> </tr> </tbody> </table>	Coding	Description	0x0001	Fault within the digital outputs	0x0002	Error while comparing the time base	0x0004	Address error while reading the time base	0x0008	Parameters for time base faulty	0x0010	Address error while reading the counter reading	0x0020	Counter configuration corrupted	0x0040	Address error while reading the Gray code	0x0080	FTT test of test pattern faulty	0x0100	FTT test - error while checking the coefficients	0x0200	Fault during the initial module configuration
Coding	Description																							
0x0001	Fault within the digital outputs																							
0x0002	Error while comparing the time base																							
0x0004	Address error while reading the time base																							
0x0008	Parameters for time base faulty																							
0x0010	Address error while reading the counter reading																							
0x0020	Counter configuration corrupted																							
0x0040	Address error while reading the Gray code																							
0x0080	FTT test of test pattern faulty																							
0x0100	FTT test - error while checking the coefficients																							
0x0200	Fault during the initial module configuration																							
Counter[0x].Error Code [BYTE]	R	Error codes of counter channels 1 and 2 <table border="1"> <thead> <tr> <th>Coding</th> <th>Description</th> </tr> </thead> <tbody> <tr> <td>0x01</td> <td>Error in counter module</td> </tr> <tr> <td>0x02</td> <td>Error while comparing the counter readings</td> </tr> <tr> <td>0x04</td> <td>Error while comparing the counter timestamps</td> </tr> <tr> <td>0x08</td> <td>Error while setting the parameters (reset)</td> </tr> </tbody> </table>	Coding	Description	0x01	Error in counter module	0x02	Error while comparing the counter readings	0x04	Error while comparing the counter timestamps	0x08	Error while setting the parameters (reset)												
Coding	Description																							
0x01	Error in counter module																							
0x02	Error while comparing the counter readings																							
0x04	Error while comparing the counter timestamps																							
0x08	Error while setting the parameters (reset)																							
Counter[0x].Value [UDINT]	R	Content of counters: 24 bit for pulse counter, 3 bit for Gray code																						
Counter[0x].Timestamp [UDINT]	R	Timestamp for <i>Counter[0x].Value</i> 24 bit, 1 μs time resolution																						
Counter[0x].Value Overflow [BOOL]	R	Counter overflow indication TRUE: 24-bit overflow since last cycle (only if <i>Counter[0x].Auto. Advance Sense</i> = FALSE) FALSE: No overflow since last cycle																						
Counter[0x].Time Overflow [BOOL]	R	Overflow indication for the timestamp of the counters TRUE: 24-bit overflow since last measurement FALSE: No 24-bit overflow since last measurement																						
Counter[0x].Direction [BOOL]	R/W	Count direction of counter (only if <i>Counter[0x].Auto. Advance Sense</i> = FALSE) TRUE: Downwards (decrement) FALSE: Upwards (increment) TRUE: Downwards (decrement) FALSE: Upwards (increment)																						
Counter[0x].Auto. Advance Sense [BOOL]	R/W	Automatic count direction recognition TRUE: Automatic recognition On FALSE: Manual configuration of the count direction																						

4 Start-Up**F35**

System Signal	R/W	Description
Counter[0x].Reset [BOOL]	R/W	Counter reset TRUE: No reset FALSE: Reset
Counter[0x].5/24 V Mode [BOOL]	R/W	5 V or 24 V counter input TRUE 24 V FALSE 5 V
Counter[0x].Gray Code [BOOL]	R/W	Decoder / pulse operation TRUE: Gray code decoder FALSE: Pulse operation

Table 47: ELOP II Factory - Counter System Signals

4.5 Connection Variants

4.5.1 Wired Mechanical Contacts on Analog Inputs

Wired mechanical contacts can be evaluated with the analog inputs using the wiring shown in Figure 11.

The Z 7308 shunt adapter must be attached between the mechanical contact and the the analog inputs. The shunt adapter protects the analog input against overvoltage and short-circuits.

Each analog input of the F35 has a separated supply output that is supplied by a common AI power source. The supply voltage lies between 26.7 V and 27.3 V.

For monitoring purposes, the used supply outputs (S1...S8) must be connected in parallel and evaluated with a digital input. The evaluation of the digital input is analog and must be configured accordingly.

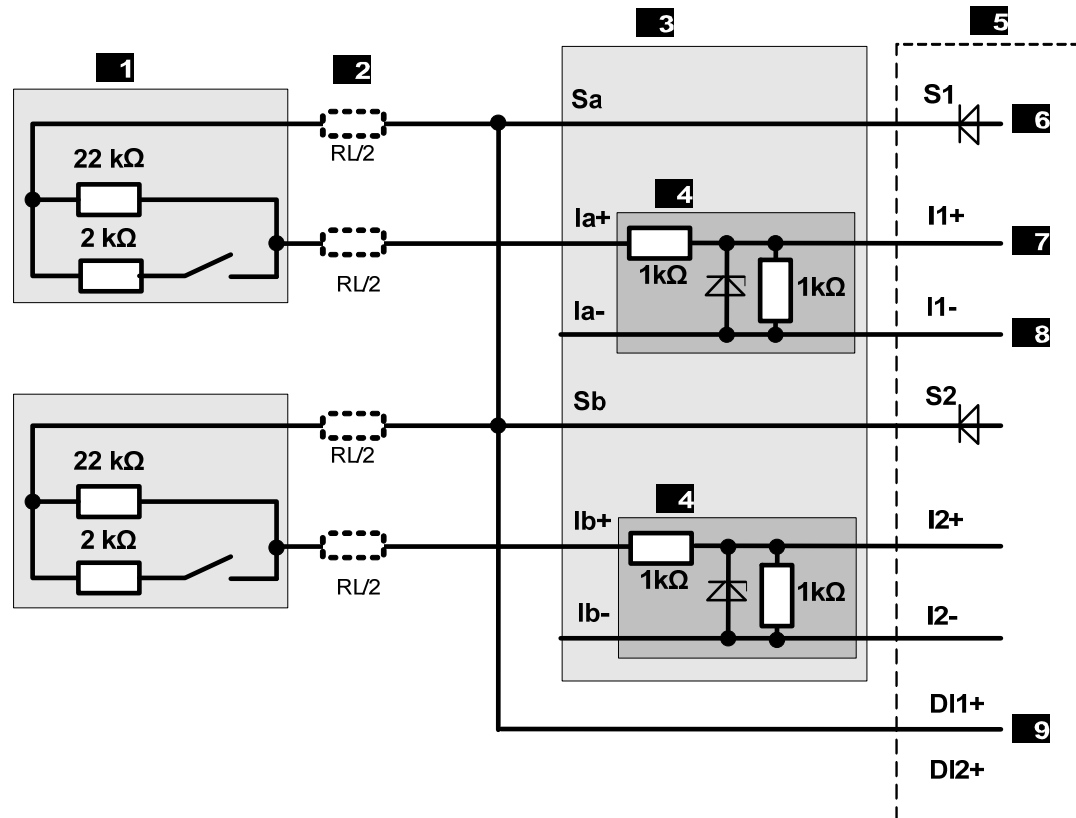

- | | |
|--|--|
| 1 Wired Mechanical Contact | 6 26.7 V...27.3 V Supply |
| 2 Line Resistance of <math>< 30 \Omega</math> | 7 Analog Input |
| 3 Z 7308 Shunt Adapter | 8 Ground |
| 4 Protective Circuit within Z 7308 | 9 Digital Input Used for Monitoring |
| 5 F35 Controller | |

Figure 11: Wired Mechanical Contact on Analog Inputs

4.5.1.1 Switching Thresholds of AI for Mechanical Contacts

The following switching thresholds and fault reactions must be defined in the user program with the FS 2000 setting. The value for the switching thresholds specified in Table 48 apply for wired mechanical contacts with resistance values of 2 k Ω and 22 k Ω , see Figure 11.

Switching thresholds	Range of 2000 digits	Description
Switch-on threshold L \rightarrow H	6 V [1200 digits]	Transition from Low to High
Switch-off threshold H \rightarrow L	3 V [600 digits]	Transition from High to Low
LB threshold	\leq 0.5 V [100 digits]	Fault reaction to be configured: Set the input value to faulty.
LS threshold	\geq 8.4 V [1680 digits]	Fault reaction to be configured: Set the input value to faulty.

Table 48: Switching Thresholds for the Analog Inputs

4.5.1.2 Switching Thresholds of the Digital Inputs Used for Monitoring

The supply must be read back by a digital channel.

Enter the following values in the system parameters for the DI channel.

System parameter	Value
Hysteresis LOW [INT] ->	< 26 V [2600 digits]
Hysteresis HIGH [INT] ->	> 28 V [2800 digits]

Table 49: Switching Thresholds for the Digital Inputs

If the supply voltage is out of the range limits, the input value must be set to faulty to allow processing in the user program.

If the supply voltage is once again within the defined range limits, operations can be resumed.

4.5.2 Wired Mechanical Contacts on Digital Inputs

Wired mechanical contacts can be evaluated with the digital inputs such as represented in Figure 12.

The F35 is equipped with 24 digital inputs. These are arranged in 3 groups of 8 digital inputs each. Each group has a separated supply. The supply voltage lies between 16.7 V and 26.9 V.

Each of the 3 supply voltages must be monitored by a digital input. This monitoring serves as the basis for the LS threshold of the other 7 digital input channels.

The evaluation of the digital inputs is analog and must be configured accordingly.

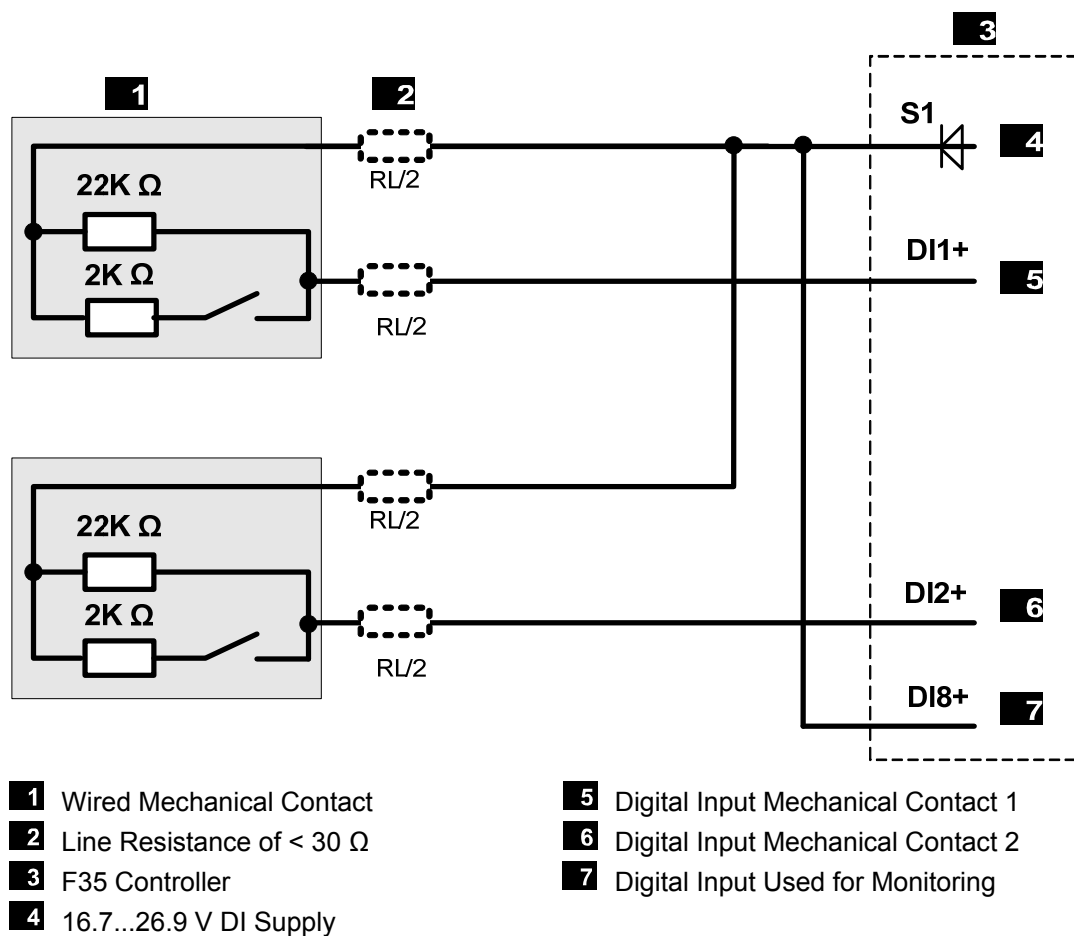

Figure 12: Wired Mechanical Contact on Digital Inputs

4.5.2.1 Switching Thresholds of the Digital Inputs for Mechanical Contacts

The following switching thresholds and fault reactions must be defined in the user program.

The LS threshold must be determined in the user program by reading back the voltage supply. The LS threshold is equal to the measured supply value minus 1.1 V, see Table 50.

The values for the switching thresholds specified in Table 50 apply for wired mechanical contacts with resistance values of 2 kΩ and 22 kΩ, see Figure 12.

Switching thresholds	Value	Description
Switch-on threshold L → H	> 12 V [1200 digits]	Transition from Low to High
Switch-off threshold H → L	< 10 V [1000 digits]	Transition from High to Low
LB threshold	< 2 V [200 digits]	Fault reaction to be configured: Set the input value to zero.
LS threshold	Supply - 1.1 V [110 digits]	Fault reaction to be configured: Set the input value to zero.

Table 50: Switching Thresholds for the Digital Inputs

4.5.2.2 Digital Input Used for Monitoring

The supply must be read back by a digital channel for creating the LS threshold, see Table 50.

5 Operation

The F35 controller is ready to operate. No specific monitoring is required for the controller.

5.1 Handling

Handling of the controller during operation is not required.

5.2 Diagnosis

A first diagnosis results from evaluating the LEDs, see Chapter 3.4.1.

The device's diagnostic history can also be read using the programming tool.

6 Maintenance

No maintenance measures are required during normal operation.

If a device or module fails, replace it with an identical type or an alternative type which is admitted by HIMA.

Only the manufacturer is authorized to repair the device/module.

6.1 Faults

Refer to Chapter 3.1.1.1, for more information on the fault reaction of digital inputs.

Refer to Chapter 3.1.2.1, for more information on the fault reaction of digital outputs.

Refer to Chapter 3.1.3.1, for more information on the fault reaction of counters.

Refer to Chapter 3.1.4.2, for more information on the fault reaction of analog inputs.

6.1.1 Operating System Version 6.42 and Beyond

If the test harnesses detect faults in the processor system, the device is rebooted. If a further internal fault occurs within the first minute after the reboot, the device enters the STOP_INVALID state and will remain in this state. This means that the input signals are no longer processed by the device and the outputs switch to the safe, de-energized state. The evaluation of diagnostics provides information on the fault cause.

6.1.2 Operating System Versions Prior to 6.42

If the test harnesses detect faults in the processor system, the module automatically enters the ERROR STOP state and will remain in this state. This means that the input signals are no longer processed by the device and the outputs switch to the safe, de-energized state. The evaluation of diagnostics provides information on the fault cause.

6.2 Maintenance Measures

The following measures are rarely required for the processor module:

- Loading the operating system, if a new version is required
- Executing the proof test

6.2.1 Loading the Operating System

HIMA is continuously improving the operating system of the devices. HIMA recommends to use system downtimes to load a current version of the operating system into the devices.

Refer to the release list to check the consequences of the new operation system version on the system!

Load the operating system using the programming tool.

Prior to loading the operating system, the device must be in STOP (displayed in the programming tool). Otherwise, stop the device.

For more information, refer to the programming tool documentation.

6.2.2 Proof Test

Test the HIMatrix devices and modules every 10 years. For more information, refer to the Safety Manual (HI 800 003 E).

7 Decommissioning

Remove the supply voltage to decommission the device. Afterwards pull out the pluggable screw terminal connector blocks for inputs and outputs and the Ethernet cables.

8 Transport

To avoid mechanical damage, HIMatrix components must be transported in packaging.

Always store HIMatrix components in their original product packaging. This packaging also provides protection against electrostatic discharge. Note that the product packaging alone is not suitable for transmission.

9 Disposal

Industrial customers are responsible for correctly disposing of decommissioned HIMatrix hardware. Upon request, a disposal agreement can be arranged with HIMA.

All materials must be disposed of in an ecologically sound manner.

Appendix

Glossary

Term	Description
ARP	Address Resolution Protocol: Network protocol for assigning the network addresses to hardware addresses
AI	Analog Input
COM	COMmunication module
CRC	Cyclic Redundancy Check
DI	Digital Input
DO	Digital Output
ELOP II Factory	Programming tool for HIMatrix systems
EMC	ElectroMagnetic Compatibility
EN	European Norm
ESD	ElectroStatic Discharge
FB	FieldBus
FBD	Function Block Diagrams
FTA	Field Termination Assembly
FTT	Fault Tolerance Time
ICMP	Internet Control Message Protocol: Network protocol for status or error messages
IEC	International Electrotechnical Commission
MAC address	Media Access Control address: Hardware address of one network connection
PADT	Programming And Debugging Tool (in accordance with IEC 61131-3), PC with SILworX or ELOP II Factory
PE	Protective Earth
PELV	Protective Extra Low Voltage
PES	Programmable Electronic System
PFD	Probability of Failure on Demand, probability of failure on demand of a safety function
PFH	Probability of Failure per Hour, probability of a dangerous failure per hour
R	Read: The system variable or signal provides value, e.g., to the user program
Rack ID	Base plate identification (number)
Non-reactive	Supposing that two input circuits are connected to the same source (e.g., a transmitter). An input circuit is termed <i>non-reactive</i> if it does not distort the signals of the other input circuit.
R/W	Read/Write (column title for system variable/signal type)
SB	System Bus (module)
SELV	Safety Extra Low Voltage
SFF	Safe Failure Fraction, portion of safely manageable faults
SIL	Safety Integrity Level (in accordance with IEC 61508)
SILworX	Programming tool for HIMatrix systems
SNTP	Simple Network Time Protocol (RFC 1769)
S.R.S	System.Rack.Slot addressing of a module
SW	Software
TMO	TiMeOut
W	Write: System variable/signal is provided with value, e.g., from the user program
WD	WatchDog: Time monitoring for modules or programs. If the watchdog time is exceeded, the module or program enters the ERROR STOP state.
WDT	WatchDog Time

Index of Figures

Figure 1: Connections to Safety-Related Digital Inputs	14
Figure 2: Connection of Actuators to Outputs	15
Figure 3: Circuitry for Line Monitoring	18
Figure 4: Sample Type Label	21
Figure 5: Front View	22
Figure 6: Block Diagram	22
Figure 7: Sample MAC Address Label	26
Figure 8: HIMatrix F35 Subsea / -20° with Aluminum Plate	36
Figure 9: Aluminum Plate with Dimensions	37
Figure 10: Label for Ex Conditions	42
Figure 11: Wired Mechanical Contact on Analog Inputs	59
Figure 12: Wired Mechanical Contact on Digital Inputs	61

Index of Tables

Table 1:	HIMatrix System Variants	7
Table 2:	Additional Relevant Documents	8
Table 3:	Environmental Requirements	11
Table 4:	Input Values for the Analog Inputs	17
Table 5:	Values for Circuitry for Line Monitoring	18
Table 6:	Part Numbers	20
Table 7:	Operating Voltage LED	23
Table 8:	System LEDs	24
Table 9:	Ethernet Indicators	25
Table 10:	I/O LEDs	25
Table 11:	Ethernet Interfaces Properties	26
Table 12:	Network Ports (UDP Ports) in Use	26
Table 13:	Network Ports (TCP Ports) in Use	27
Table 14:	Connections for Fieldbus Communication	27
Table 15:	Pin Assignment of D-sub Connectors FB1 and FB2 for PROFIBUS DP	27
Table 16:	Pin Assignment of the D-sub Connectors FB1 and FB2 for RS485	28
Table 17:	Pin Assignment of the D-sub Connectors FB1 and FB2 for RS232	28
Table 18:	Pin Assignment of the D-sub Connectors FB1 and FB2 for RS422	28
Table 19:	Pin Assignment of the D-sub Connectors FB1 and FB2 for INTERBUS	29
Table 20:	Pin Assignment of D-sub Connector FB3 for Modbus	29
Table 21:	Configuration of Counter Function 1	30
Table 22:	Configuration of Counter Function 2	31
Table 23:	Configuration of Decoder Operation	31
Table 24:	Comparison of the Codes Used	31
Table 25:	Product Data	33
Table 26:	Specifications for the Digital Inputs	34
Table 27:	Specifications for the Analog Inputs	34
Table 28:	Specifications for the Digital Outputs	35
Table 29:	Specifications for the Counters	35
Table 30:	Product Data F35 011 (-20 °C)	35
Table 31:	Product Data F35 012 (Subsea / -20 °C)	36
Table 32:	Certificates	37
Table 33:	Terminal Assignment for the Digital Inputs	38
Table 34:	Terminal Assignment for the Digital Outputs	39
Table 35:	Terminal Assignment for the Counters	39
Table 36:	Terminal Assignment for the Analog Inputs	40
Table 37:	Shunt Adapter	41
Table 38:	SILworX - System Parameters for the Digital Outputs, Module Tab	44

Appendix	F35
Table 39: SILworX - System Parameters for the Digital Outputs, DO 8: Channels Tab	45
Table 40: SILworX - System Parameters for the Counters, Module Tab	47
Table 41: SILworX - System Parameters for the Digital Inputs, Module Tab	48
Table 42: SILworX - System Parameters for the Inputs, MI 24/8 FS1000: AI Channels Tab	49
Table 43: SILworX - System Parameters for the Digital Inputs, MI 24/8 FS1000: DI Channels Tab	50
Table 44: ELOP II Factory - Digital Input System Signals	53
Table 45: ELOP II Factory - Analog Input System Signals	55
Table 46: ELOP II Factory - Digital Output System Signals	56
Table 47: ELOP II Factory - Counter System Signals	58
Table 48: Switching Thresholds for the Analog Inputs	60
Table 49: Switching Thresholds for the Digital Inputs	60
Table 50: Switching Thresholds for the Digital Inputs	62

Index

diagnosis	63	line monitoring	18
fault reaction		part numbers	20
analog Inputs	19	reset key.....	32
counter inputs	16	safeethernet	26
digital inputs	14	shunt adapter	41
digital outputs.....	15	specifications.....	33
line control	14	SRS.....	20



SAFETY
NONSTOP

HIMA Paul Hildebrandt GmbH + Co KG

P.O. Box 1261

68777 Brühl, Germany

Tel: +49 6202 709-0

Fax: +49 6202 709-107

E-mail: info@hima.com Internet: www.hima.com

CONTACT US & SUPPORT

NEED A QUOTE OR TECHNICAL PARTS REPLACEMENT?

Company: [PLC ProTech Ltd.](#)
Website: www.plcprotech.com
Email: sales@plcprotech.com
Phone: +86 180 4631 7198

Our Service Guarantee:

- 100% Brand New Original & Factory Sealed Components
- 12-Month Quality Warranty on All Industrial Parts
- Worldwide Same-Day Fast Dispatch via DHL / FedEx

[SUBMIT ONLINE RFQ \(REQUEST FOR QUOTE\) >>](#)

[About Us](#) · [Contact](#) · [All Products](#)