

Analog Voltage Input - 16 Channel IC693ALG222

The *16-Channel Analog Voltage Input* module provides up to 16 single-ended or eight differential input channels, each capable of converting an analog input signal to a digital value for use as required by your application. This module provides two input ranges:

- 0 to 10 V (unipolar)
- -10 to +10 V (bipolar)

Voltage Ranges and Input Modes

The default input mode and range is single-ended, unipolar, with the user data scaled so that 0 volts corresponds to a count of 0 and 10 volts corresponds to a count of +32000. The other range and mode are selected by changing the configuration parameters using the Logicmaster 90-30/20/Micro or CIMPLICITY Control configurator software, or the Hand-Held Programmer. The range can be configured for bipolar -10 to +10 V where -10 V corresponds to a count of -32000, 0 V corresponds to a count of 0, and +10 V corresponds to a count of +32000.

High and Low alarm limits are available on all ranges. Ranges can be configured on a per channel basis.

Power Requirements and LEDs

This module consumes a maximum of 112 mA from the 5V bus on the PLC backplane. It also requires a maximum of 41 mA from the backplane Isolated+24 Volt DC supply to power the on-board power converter that provides isolated ± 5 V supplies to power the user-side circuitry (see Table 3-9, *Specifications*).

There are two green LED indicators on the module which provide module and user supply status. The top LED, **MODULE OK** provides module status information on power-up as follows:

- *ON*: status is OK, module configured
- *OFF*: no backplane power or software not running (watchdog timer timed out)
- *Continuous rapid flashing*: configuration data not received from CPU
- *Slow flashes, then OFF*: failed power-up diagnostics or encountered code execution error

The bottom LED, **Power Supply OK**, indicates that the internally generated user-side +5V supply is above a minimum designated level.

Location in System

This module can be installed in any I/O slot of a 5 or 10-slot baseplate in a Series 90-30 PLC system.

References Used

The number of 16-Channel Analog Voltage Input modules which may be installed in a system depends on the amount of %AI and %I references available. Each module uses 1 to 16 %AI references (depending on the number of channels enabled) and from 8 to 40 %I references (depending on alarm status configuration).

The available %AI references are: 64 with CPUs 311, 313, and 323; 128 with CPU331; 1024 with CPUs 340 and 341; and 2048 with CPUs 350 – 364.

10

The maximum number of 16-Channel Analog Voltage Input modules which may be installed in a system are:

- 4 in a system using CPUs 311, 313, or 323
- 8 in a system using CPU331
- 12 in a system using CPUs 340 or 341
- 51 in a system using CPUs 350 – 364

When planning the module configuration for your application you must also consider the load capacity of the installed power supply and the total load requirements of all modules that are installed in the baseplate.

Refer to the *Series 90-30 Programmable Controller Installation Manual*, GFK-0356 for details on power supplies and module load requirements.

Table 10-3. Specifications for 16-Channel Analog Voltage Input Module, IC693ALG222

Number of Channels	1 to 16 selectable, single-ended 1 to 8 selectable, differential
Input Current Ranges	0V to +10V (unipolar) or -10V to +10V (bipolar); selectable each channel
Calibration	Factory calibrated to: 2.5 mV per count on 0V to +10V (unipolar) range 5 mV per count on -10 to +10V (bipolar) range
Update Rate	6 msec (all 16 single-ended channels) 3 msec (all 8 differential channels)
Resolution at 0V to +10V	2.5 mV (1 LSB = 2.5 mV)
Resolution at -10V to +10V	5 mV (1 LSB = 5 mV)
Absolute Accuracy ‡	± 0.25% of full scale @ 25°C (77°F) ± 0.5% of full scale over specified operating temperature range
Linearity	< 1 LSB
Isolation	1500 volts between field side and logic side
Common Mode Voltage (Differential)	± 11V (bipolar range) †
Cross-Channel Rejection	> 80 db from DC to 1 kHz
Input Impedance	>500K ohms (single-ended mode) >1M ohms (differential mode)
Input Filter Response	41 Hz (single-ended mode) 82 Hz (differential mode)
Internal Power Consumption	112 mA (maximum) from the backplane +5 VDC bus 41 mA (maximum) from the backplane Isolated +24 VDC supply

Refer to Appendix B for product standards and general specifications.

† The summation of the differential input, common-mode voltage, and noise must not exceed ±11 volts when referenced to COM.

‡ In the presence of severe RF interference (IEC 801-3, 10V/m), accuracy may be degraded to ±5% FS.

CPU Interface to the IC693ALG 222 Analog Voltage Input Module

The Series 90-30 PLC uses the data within the %AI data table to record analog values for use by the programmable controller. This scheme for the 16-Channel Analog Voltage Input module is shown below. More information on the CPU interface to analog modules can be found at the beginning of this chapter.

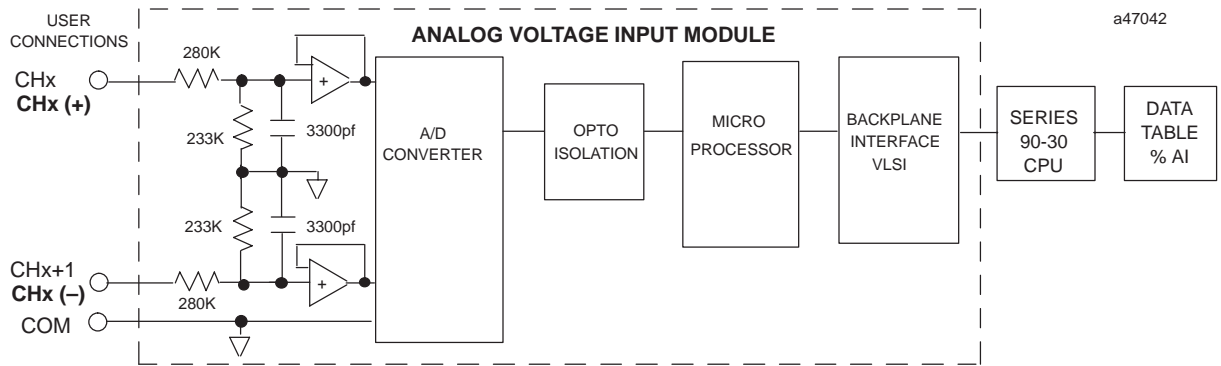

NOTE: CHx AND CHx+1 INDICATE SINGLE-ENDED MODE; CHx (+) AND CHx (-) INDICATE DIFFERENTIAL MODE

Figure 10-9. 16-Channel Analog Voltage Input Module Block Diagram - IC693ALG222

Placement of A/D Bits within the Data Tables

Since converters used in the analog modules are 12-bit converters, not all of the 16 bits in the data tables contain data required for the conversion. A version of the 12 bits is placed within the 16-bit data word corresponding to the analog point (in the %AI table). The Series 90-30 PLC system handles the integration differently for the various analog modules.

The CPU does not manipulate the data from the input modules before placing it within the word in the %AI data table. The bits in the %AI data table which were not used in the conversion by the input module are either forced to 0 (zero) by the analog input module. Placement of the 12 data bits from the A/D converter for an analog current input data word for the 16-Channel Analog Voltage Input module in unipolar range is shown below.

MSB												LSB			
X	D11	D10	D9	D8	D7	D6	D5	D4	D3	D2	D1	D0	X	X	X

X=not converted bits

Analog values are scaled over the range of the converter. Factory calibration adjusts the analog value per bit (resolution) to a multiple of full scale (that is, 2.5 mV/bit for unipolar; 5 mV/bit for bipolar). This calibration leaves a normal 12-bit converter with 4000 counts (normally $2^{12} = 4096$ counts). The data is then scaled with the 4000 counts over the analog range. For example, the data to the A/D converter for the 16-Channel Analog Voltage Input is scaled as shown below.

10

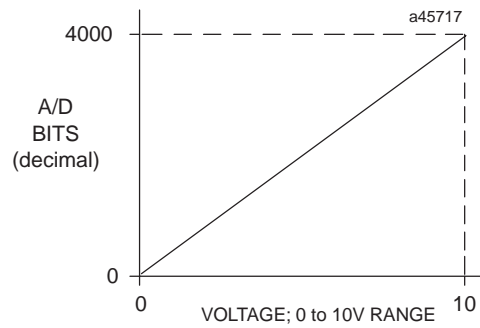

Figure 10-10. A/D Bits vs. Voltage Input for IC693ALG222

IC693ALG222 Analog Module Field Wiring Connections

Connections to this module from user devices are made to screw terminals on a removable 20-terminal connector block mounted on the front of the module. The actual terminals used are described in the following table and are shown in the following wiring diagrams.

Terminal Assignments

Pin assignments for the 20 terminal I/O connector on the 16-Channel Analog Voltage Input module are as shown in the following table.

Table 10-4. Terminal Pin Assignments for IC693ALG222

Pin Number	Signal Name	Signal Definition
1	n/a	not used
2	n/a	not used
3	CH1	Single Ended Channel 1, Differential Channel 1 (Positive terminal)
4	CH2	Single Ended Channel 2, Differential Channel 1 (Negative terminal)
5	CH3	Single Ended Channel 3, Differential Channel 2 (Positive terminal)
6	CH4	Single Ended Channel 4, Differential Channel 2 (Negative terminal)
7	CH5	Single Ended Channel 5, Differential Channel 3 (Positive terminal)
8	CH6	Single Ended Channel 6, Differential Channel 3 (Negative terminal)
9	CH7	Single Ended Channel 7, Differential Channel 4 (Positive terminal)
10	CH8	Single Ended Channel 8, Differential Channel 4 (Negative terminal)
11	CH9	Single Ended Channel 9, Differential Channel 5 (Positive terminal)
12	CH10	Single Ended Channel 10, Differential Channel 5 (Negative terminal)
13	CH11	Single Ended Channel 11, Differential Channel 6 (Positive terminal)
14	CH12	Single Ended Channel 12, Differential Channel 6 (Negative terminal)
15	CH13	Single Ended Channel 13, Differential Channel 7 (Positive terminal)
16	CH14	Single Ended Channel 14, Differential Channel 7 (Negative terminal)
17	CH15	Single Ended Channel 15, Differential Channel 8 (Positive terminal)
18	CH16	Single Ended Channel 16, Differential Channel 8 (Negative terminal)
19	COM	Common connection for Single Ended Channels
20	GND	Frame ground connections for cable shields

10

IC693ALG222 Analog Input Module Field Wiring Diagrams

The following figures provide information for connecting field wiring to the user terminal board on the 16-Channel Analog Voltage Input Module.

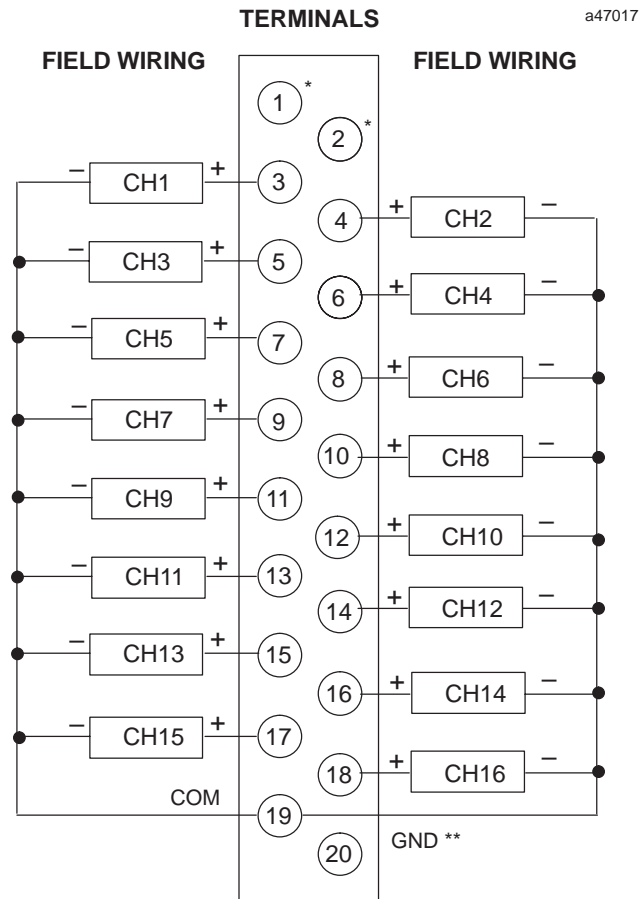

* NOT CONNECTED
 ** OPTIONAL SHIELD CONNECTION

Figure 10-11. Field Wiring for 16-Channel Analog Voltage Input Module - IC693ALG222 (Single-Ended Mode)

Note

Please refer to Chapter 2 for wiring and shield ground connection details.

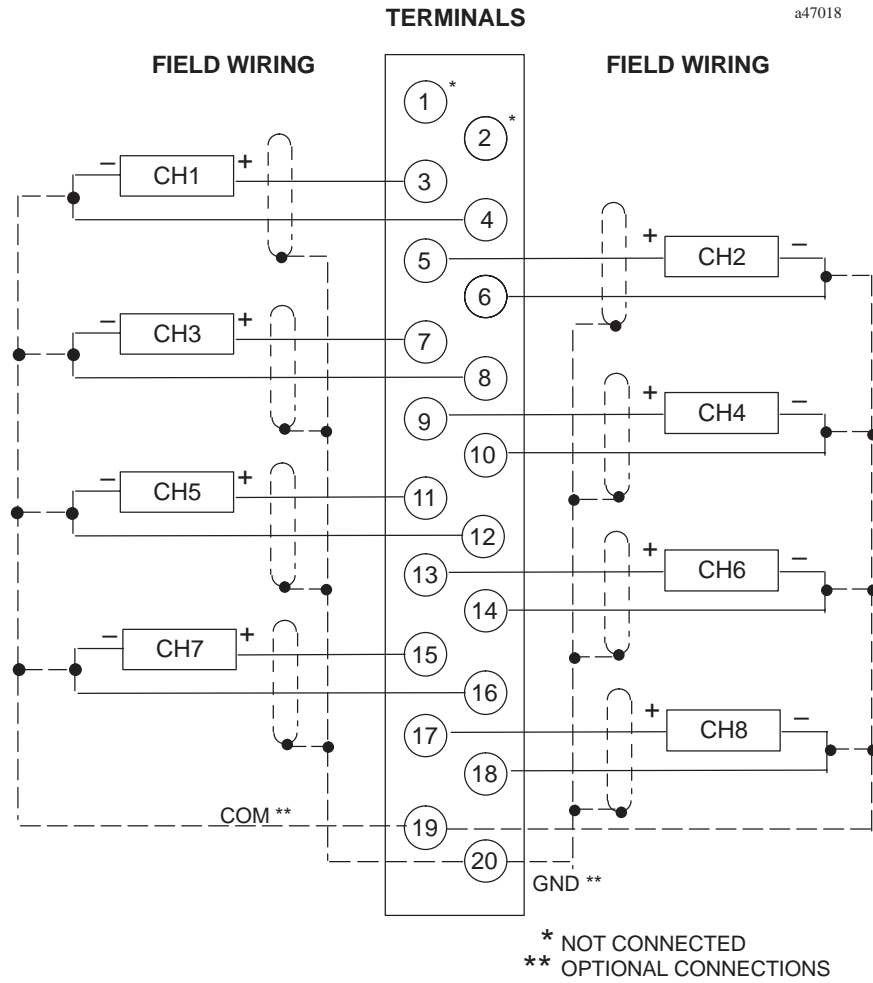

Figure 10-12. Field Wiring for 16-Channel Analog Voltage Input Module - IC693ALG222 (Differential Mode)

Note

Please refer to Chapter 2 for wiring and shield ground connection details.

IC693ALG222 Analog Voltage Input Block Diagram

The following figure is a block diagram of the 16-Channel Analog Voltage Input Module.

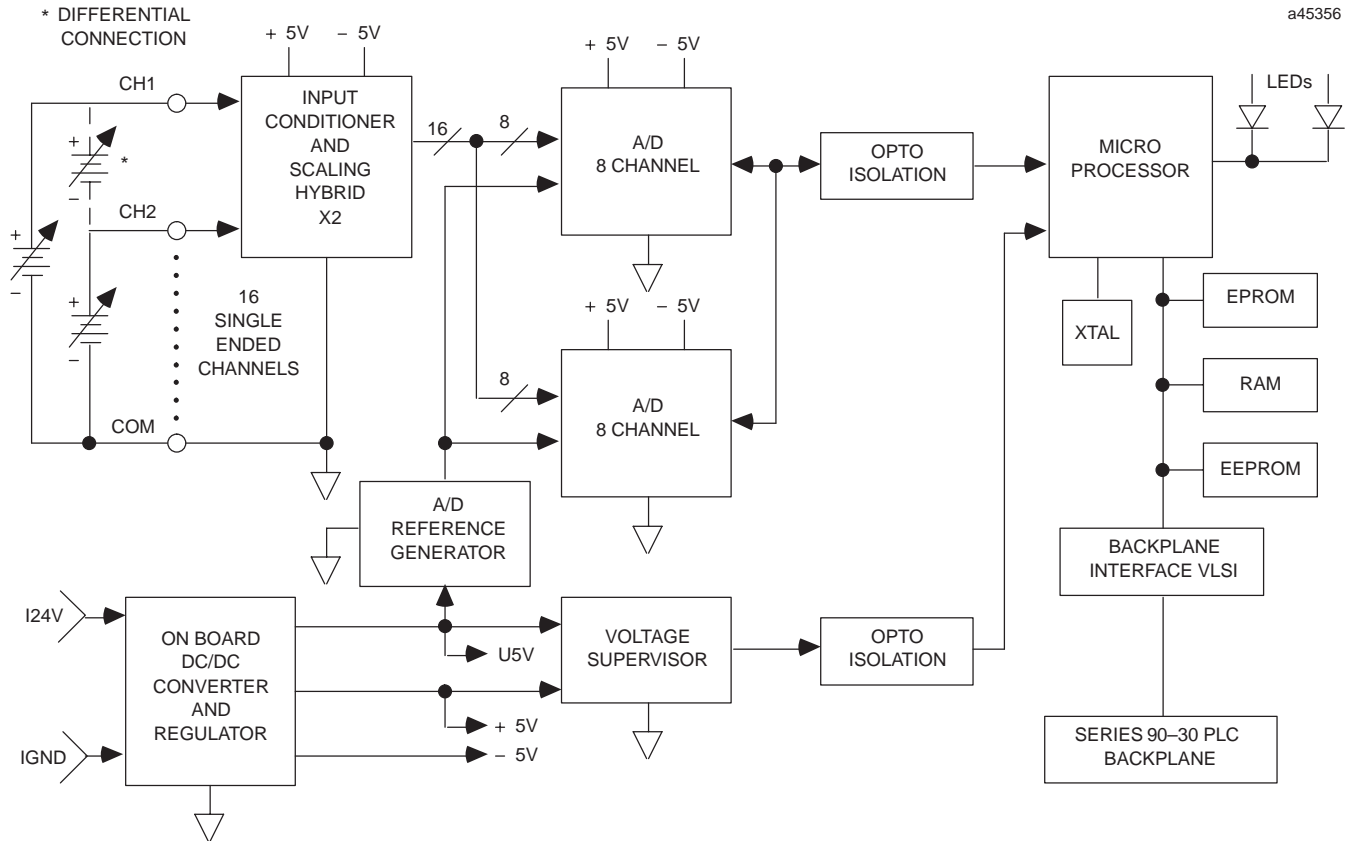

Figure 10-13. 16-Channel Analog Voltage Input Module Block Diagram - IC693ALG222

IC693ALG222 Analog Input Module Configuration

The 16-Channel Analog Voltage Input module can be configured using either the Logicmaster 90-30/20/Micro Programming Software configurator function or with the Hand-Held Programmer.

The parameters that may be configured are described in the following table. Configuration procedures using Logicmaster 90-30/20/Micro Programming Software and the Hand-Held Programmer are described in the following pages.

Table 10-5. Configuration Parameters for IC693ALG222

Parameter Name	Description	Values	Default Values	Units
<i>Active Channels</i>	Number of channels converted	1 through 16	1 (Logicmaster 90-30/20/Micro) 16 (Hand-Held programmer)	n/a
<i>Ref Adr</i>	Starting address for %AI reference type	standard range	%AI0001, or next highest available address	n/a
<i>Ref Adr</i>	Starting address for %I reference type	standard range	%I00001, or next highest available address	n/a
<i>%I Size</i>	Number of %I status locations	8, 16, 24, 32, 40	8 (Logicmaster 90-30) 40 (Hand-Held Programmer)	bits
<i>Range</i>	Range	0 to 10V or -10 to 10V	0 to 10V	n/a
<i>Alarm Low</i>	Low limit alarm value	-32767 to +32759	0	User counts
<i>Alarm High</i>	High limit alarm value	-32766 to +32760	+32000	User counts

For more information on configuration, see

- *Configuration Using Logicmaster 90-30/20/Micro Programming Software* beginning on page 3-25 and
- *Configuration Using the Hand-Held Programmer* beginning on page 3-29.

10

IC693ALG222 Configuration Using Logicmaster Software

This section describes how you can configure the 16-Channel High Density Analog Voltage Input module using the configurator function in Logicmaster 90-30/20/Micro Programming Software. *Configuration can also be done using CIMPLICITY Control Programming Software. For details refer to the CIMPLICITY Control online help.*

To configure a 16-Channel Analog Voltage Input Module on the I/O Configuration Rack screen:

1. Move the cursor to the slot where the module will be located, and press the **m30 io** softkey (F1). In the following example screen, the module will be placed in slot 5 of the main rack.

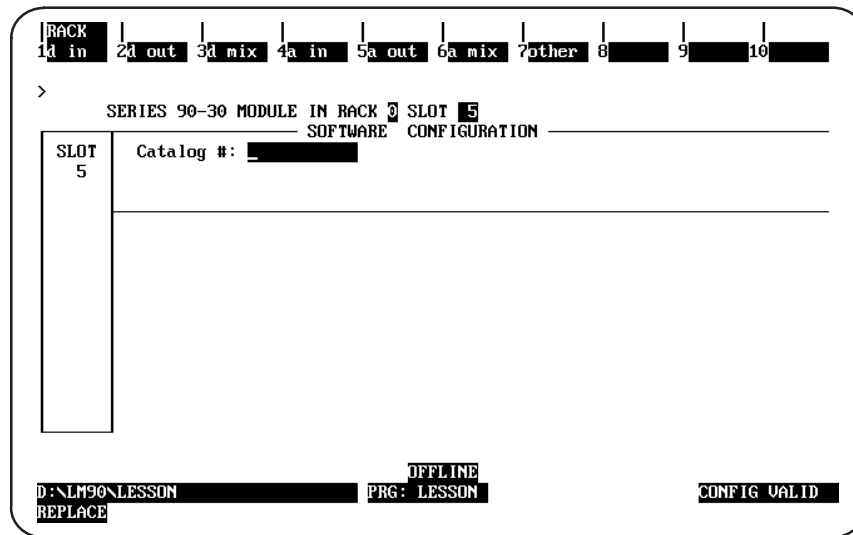

2. Press the **a in**, softkey (F4) to display a list of available analog input modules and their catalog numbers.

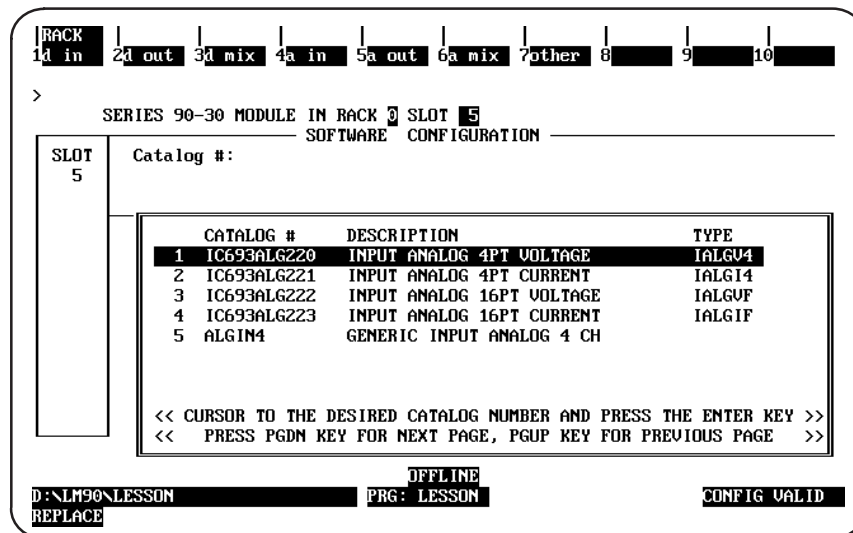

- To select the 16-Channel Analog Voltage Input Module, position the cursor on the catalog number for the module, IC693ALG222, and press the **Enter** key.

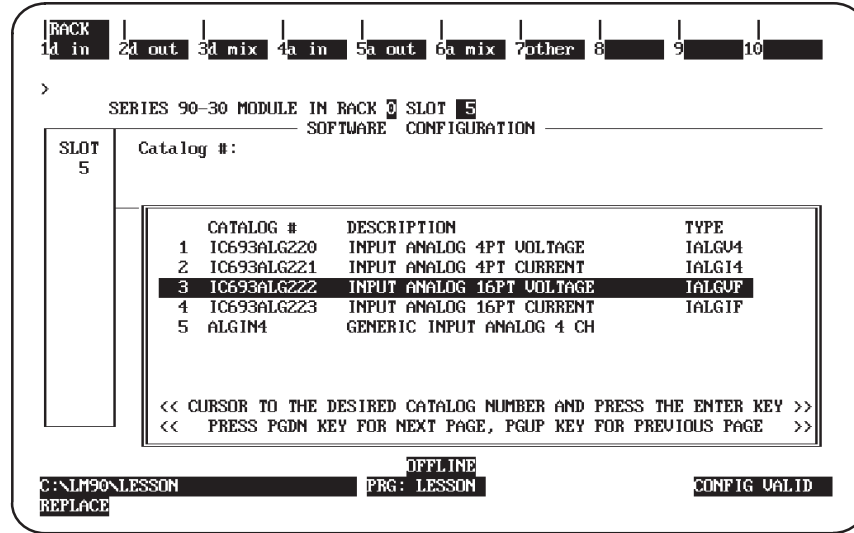

- After pressing the Enter key, the first detail screen, shown below, is displayed. You can then configure the module as required for your application.

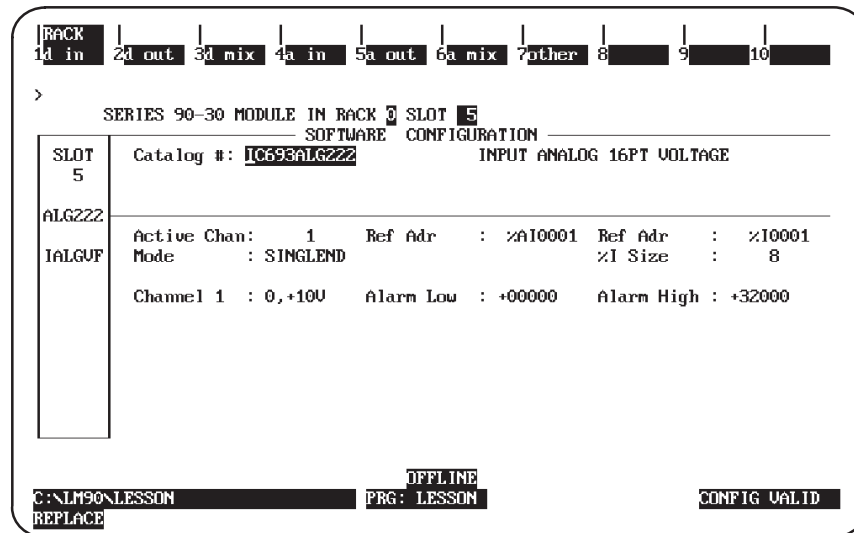

Note

Only enabled (active) channels are displayed on the screen

- Use the parameter descriptions provided in the following table to help you make selections for the parameters on this screen.

Table 10-6. Parameter Descriptions for Configuration

Parameter	Description
Active Channel	Enter a number from 1* through 16 for Single Ended or 1* through 8 for Differential . This number represents the number of channels to be converted. Channels are scanned in sequential, contiguous order, with channel No. 1 being the first channel scanned. If more than eight channels are selected, a second detail screen will be displayed to allow you to enter data in channels 9 through 16.
Reference Address	The first Reference Address field contains the reference address for %AI data. The address points to the location in %AI memory where input data to the module begins. Each channel provides 16 bits of analog input data as an integer value from 0 to 32,760 or -32,767 to 32,752, depending on the range type selected.
Reference Address	The second Reference Address field contains the reference address for %I data. The address points to the location in %I memory where status information from the module begins. You can select the number of %I status locations reported to the PLC by editing the value in the %I Size field.
Mode	The Mode field describes what type user connection to the terminal board is desired. In *Single Ended mode, there are 16 inputs referenced to a single common. In Differential mode each of the 8 inputs has its own signal and common, thereby using two points on the terminal board for each channel.
%I Size	Enter the number of %I locations reported to the PLC. Choices are 0, 8, 16, 24, 32, or 40. The data is brought back in the following format:
	First eight %I locations: (available for %I SIZE values 8, 16, 24, 32, and 40)
	<ul style="list-style-type: none"> ● %I = Module OK: 0 = module NOT OK; 1 = module OK. ● %I+1 = User Supply OK: 0 = below limit; 1 = user supply OK. ● %I+2 through %I+7 = Reserved for future modules.
	Second eight %I locations: (available for %I SIZE values 16, 24, 32, and 40)
	<ul style="list-style-type: none"> ● %I+8 = Channel No. 1 ALARM LO 0 = above limit; 1 = below or equal to limit. ● %I+9 = Channel No. 1 ALARM HI: 0 = below limit; 1 = above or equal to limit. ● %I+10 = Channel No. 2 ALARM LO: 0 = above limit; 1 = below or equal to limit. ● %I+11 = Channel No. 2 ALARM HI: 0 = below limit; 1 = above or equal to limit. ● %I+12 = Channel No. 3 ALARM LO: 0 = above limit; 1 = below or equal to limit. ● %I+13 = Channel No. 3 ALARM HI: 0 = below limit; 1 = above or equal to limit. ● %I+14 = Channel No. 4 ALARM LO: 0 = above limit; 1 = below or equal to limit. ● %I+15 = Channel No. 4 ALARM HI: 0 = below limit; 1 = above or equal to limit.
Third eight %I locations: (available for %I SIZE values 24, 32, and 40)	
<ul style="list-style-type: none"> ● %I+16 = Channel No. 5 ALARM LO 0 = above limit; 1 = below or equal to limit. ● %I+17 = Channel No. 5 ALARM HI: 0 = below limit; 1 = above or equal to limit. ● %I+18 = Channel No. 6 ALARM LO: 0 = above limit; 1 = below or equal to limit. ● %I+19 = Channel No. 6 ALARM HI: 0 = below limit; 1 = above or equal to limit. ● %I+20 = Channel No. 7 ALARM LO: 0 = above limit; 1 = below or equal to limit. ● %I+21 = Channel No. 7 ALARM HI: 0 = below limit; 1 = above or equal to limit. ● %I+22 = Channel No. 8 ALARM LO: 0 = above limit; 1 = below or equal to limit. ● %I+23 = Channel No. 8 ALARM HI: 0 = below limit; 1 = above or equal to limit. 	
Fourth eight %I locations: (available for %I SIZE values 32 and 40)	
<ul style="list-style-type: none"> ● %I+24 = Channel No. 9 ALARM LO 0 = above limit; 1 = below or equal to limit. ● %I+25 = Channel No. 9 ALARM HI: 0 = below limit; 1 = above or equal to limit. ● %I+26 = Channel No. 10 ALARM LO: 0 = above limit; 1 = below or equal to limit. ● %I+27 = Channel No. 10 ALARM HI: 0 = below limit; 1 = above or equal to limit. ● %I+28 = Channel No. 11 ALARM LO: 0 = above limit; 1 = below or equal to limit. ● %I+29 = Channel No. 11 ALARM HI: 0 = below limit; 1 = above or equal to limit. ● %I+30 = Channel No. 12 ALARM LO: 0 = above limit; 1 = below or equal to limit. ● %I+31 = Channel No. 12 ALARM HI: 0 = below limit; 1 = above or equal to limit. 	

Table 10–6. Parameter Descriptions for Configuration (continued)

Parameter	Description
%I Size (cont'd)	<p><u>Fifth eight %I locations:</u> (available for %I SIZE value 40)</p> <ul style="list-style-type: none"> ● %I+32 = Channel No. 13 ALARM LO 0 = above limit; 1 = below or equal to limit. ● %I+33 = Channel No. 13 ALARM HI: 0 = below limit; 1 = above or equal to limit. ● %I+34 = Channel No. 14 ALARM LO: 0 = above limit; 1 = below or equal to limit. ● %I+35 = Channel No. 14 ALARM HI: 0 = below limit; 1 = above or equal to limit. ● %I+36 = Channel No. 15 ALARM LO: 0 = above limit; 1 = below or equal to limit. ● %I+37 = Channel No. 15 ALARM HI: 0 = below limit; 1 = above or equal to limit. ● %I+38 = Channel No. 16 ALARM LO: 0 = above limit; 1 = below or equal to limit. ● %I+39 = Channel No. 16 ALARM HI: 0 = below limit; 1 = above or equal to limit.
Range	<p>Select the range. Choices are *0 to 10V or –10 to 10V. In the 0 to 10V default range, input voltage values ranging from 0 to 10V report 0 to 32,000 integer values to the CPU. In the –10 to 10V range, input voltage values ranging from –10 to 10V report –32000 to 32,000 integer values to the CPU.</p>
Alarm Low	<p>Enter a value that causes an alarm low indication to be passed to the PLC. Each channel has a low limit alarm value (ALARM LO), which causes %I points to be set. Values entered without a sign are assumed to be positive. Value checking should be done to determine if the alarm low values are allowed for the appropriate range. The values allowed are:</p> <ul style="list-style-type: none"> ● 0 to 10V Range = 0 to 32760 ● –10 to 10V Range = –32767 to 32752
Alarm High	<p>Enter a value that causes an alarm high indication to be passed to the PLC. Each channel has a high limit alarm value (ALARM HI), which causes %I points to be set. Values entered without a sign are assumed to be positive. Value checking should be done to determine if the alarm high values are allowed for the appropriate range. The values allowed are:</p> <ul style="list-style-type: none"> ● 0 to 10V Range = 0 to 32760 ● –10 to 10V Range = –32767 to 32752

* Default selection.

6. Press Rack (Shift-F1) or the Escape key to return to the rack display.

Configuring IC693ALG222 Using Hand-Held Programmer

You can also configure the 16-Channel Analog Voltage Input module using the Hand-Held Programmer. In addition to the information in this section, refer to GFK-0402, the *Hand-Held Programmer for Series 90-30/20/Micro Programmable Controllers User's Manual* for more information on configuration of Intelligent I/O modules.

Although you can change the number of actively scanned channels with the Logicmaster 90-30/20/Micro configurator function, the Hand-Held Programmer does not support editing the number of actively scanned channels. If the 16-Channel Analog Voltage Input module is initialized by a Hand-Held Programmer, the number of actively scanned channels is 16.

If a module had been previously configured with Logicmaster 90-30/20/Micro software and the number of actively scanned channels has been changed from 16, that number will be displayed on the bottom line of the Hand-Held Programmer display following the *AI*. You can edit data with the Hand-Held Programmer only for the active channels, but can not change the number of actively scanned channels.

Module Present

If a module is physically present in a system, it can be added to the system's configuration by *reading* the module into it. For example, assume that a 16-Channel Analog Voltage Input module is installed in slot 3 of a Model 311 PLC system. It can be added to the configuration with the following sequence. Use the Up and Down cursor keys or the # key to display the selected slot.

Initial Display

```
R0:03 EMPTY >S
```

To add the IC693ALG222 module to the configuration, press the **READ/VERIFY** key. The following screen will be displayed:

```
R0:03 HI-DEN V >S
I40:I_
```

Selecting %I Reference

At this point the starting %I reference address for the status data returned from the module must be entered. Notice that the length of the status field (**40**) is displayed as the first two digits following the first **I** on the second line of the display.

Note

This field cannot be changed with the Hand-Held programmer. However, it can be changed using the Logicmaster 90-30/20/Micro software configurator function. The Hand-Held Programmer will always reflect the currently active length of the status field.

Pressing the **ENT** key will allow the PLC to select the starting address of the status data. You can select a specific starting address by pressing the key sequence for the desired address and pressing the **ENT** key. For example to specify the starting address as I17, press the key sequence **1, 7, ENT**. The following screen will be displayed:

```
R0:03 HI-DEN V >S
I40:I17-I56
```

Selecting %AI Reference

After the starting %I address has been selected, pressing the **ENT** key again will cause the following screen to be displayed:

```
R0:03 HI-DEN V >S
AI16:AI_
```

This screen allows you to select the starting address for the %AI reference. Note that the length of the status field (**16**) is displayed as the first two digits following the first **AI** on the second line of the display.

Note

This field cannot be changed with the Hand-Held programmer. However, it can be changed using the Logicmaster 90-30/20/Micro software configurator function. The Hand-Held Programmer will always reflect the currently active length of the status field.

In the AI field you can select the next available address (the default) by pressing the **ENT** key or by entering a specific address. To enter a specific address, press the starting reference number keys and the **ENT**. key (for example **3, 5**, then **ENT**).

```
R0:03 HI-DEN V >S
AI16:AI035-AI051
```

You can press the **CLR** key at any time to abort the configuration you have just selected and return the slot to *EMPTY*.

10

Removing Module From Configuration

If required, this module can be removed from the current configuration. Assume that the module is currently configured in rack 0, slot 3. It can be deleted with the following sequence:

Initial Display

```
R0:03 HI-DEN V >S
AI16:AI_
```

To delete the module, press the **DEL**, **ENT** key sequence. The display will then be:

```
R0:03 EMPTY >S
```

Selecting Module Mode

To display the module mode, press the **→** key. The display will show the current mode of the module. The default mode is Single Ended.

Initial Display

```
R0:03 HI-DEN V >S
HI-DEN V:SINGLE
```

You can toggle between the Single Ended and Differential modes by pressing the **±** key. Each mode will be selected as shown. The range selected is the one currently displayed.

Initial Display

```
R0:03 HI-DEN V >S
HI-DEN V:DIFFERE
```

When the desired mode for the module is displayed on the screen you can selected it by pressing the **ENT** key.

Selecting Input Channel Ranges

The range for each of the 16 channels can be displayed and selected or changed as described below. Assume that the %AI address is as previously selected.

Initial Display

```
R0:03 HI-DEN V >S
HI-DEN V:SINGLE
```

To display the channel ranges press the → key. The display will show Channel 1 (or the currently selected channel) and the first available range.

```

R0:03 HI-DEN V >S
CHAN 1: 0 - 10
```

You can toggle through the range for each channel by pressing the ± key. Each range will be displayed as shown. The range selected is the one currently displayed.

```

R0:03 HI-DEN V >S
CHAN 1:-10 - 10
```

Alarm Limits Display

To view the alarm limits for the channel currently displayed, press the → key again (the first time caused the channel ranges to be available for editing). The following screen is displayed:

```

R0:03 HI-DEN V >S
CH 1 LO:      0
```

The display is the entry field for the low alarm limit for the displayed channel (in this case, Channel 1). You can enter the desired low alarm limit value using the numeric keys and the ± key for specifying negative values. Enter the low alarm limit using a value within the valid limits as listed in Table 3-7. After you have entered the low alarm limit value, press the → key again to advance to the high alarm limit display for this channel. The following screen is displayed at this time.

```

R0:03 HI-DEN V >S
CH 1: HI: 32000
```

The display shows the entry field for the high alarm limit for the currently displayed channel. You can enter positive or negative numbers (see table 3-7) using the ± and numeric keys. After selecting the low and high alarm limits for channel 1 (or the currently displayed channel), you can view the next channel by pressing the → key.

```

R0:03 HI-DEN V >S
CHAN 2:0 - 10
```

Edit the range, and low and high alarm limits as described for Channel 1. All active channels can be changed in this manner. Return to the initial display screen by pressing the ENT key or by pressing the ← key until the initial screen is displayed.

10

Saved Configurations

Configurations that contain a 16-Channel Analog Voltage Input module can be saved to an EEPROM or MEM card and read into the CPU at a later time. MEM cards and EEPROMs containing these configurations can be read into any Release 4 or later CPU. Refer to Chapter 2 of the *Hand-Held Programmer User's Manual* for detailed information on the Save and Restore operations.

CONTACT US & SUPPORT

NEED A QUOTE OR TECHNICAL PARTS REPLACEMENT?

Company: [PLC ProTech Ltd.](#)
Website: www.plcprotech.com
Email: sales@plcprotech.com
Phone: +86 180 4631 7198

Our Service Guarantee:

- 100% Brand New Original & Factory Sealed Components
- 12-Month Quality Warranty on All Industrial Parts
- Worldwide Same-Day Fast Dispatch via DHL / FedEx

[SUBMIT ONLINE RFQ \(REQUEST FOR QUOTE\) >>](#)

[About Us](#) · [Contact](#) · [All Products](#)