

Analog Current Input - 16 Channel IC693ALG223

The *16-Channel Analog Current Input* module provides up to 16 single-ended input channels, each capable of converting an analog input signal to a digital value for use as required by your application. This module provides three input ranges:

- 4 to 20 mA
- 0 to 20 mA
- 4 to 20 mA Enhanced

Current Ranges

The default range is 4 to 20 mA with user data scaled so that 4 mA corresponds to a count of 0 and 20 mA corresponds to a count of 32000. The other ranges are selected by changing the configuration parameters using the IC641 configurator software or the Hand-Held Programmer. The range can be configured so that the input range is 0 to 20 mA with user data scaled so that 0 mA corresponds to a count of 0 and 20 mA corresponds to a count of 32000. Full 12-bit resolution is available over the 4 to 20 and 0 to 20 mA ranges.

A 4 to 20 mA Enhanced range can also be selected. When this range is selected, 0 mA corresponds to a count of -8000, 4 mA corresponds to a count of 0 (zero) and 20 mA corresponds to a count of +32000. The Enhanced range uses the same hardware as the 0 to 20 mA range but automatically provides 4 to 20 mA range scaling with the exception that negative digital values are provided to the user for input current levels between 4 mA and 0 mA. This gives you the capability of selecting a low alarm limit that detects when the input current falls from 4 mA to 0 mA, which provides for open-wire fault detection in 4 to 20 mA applications. High and Low alarm limits are available on all ranges. Ranges can be configured on a per channel basis. The module also reports module status and user-side supply status to the CPU.

Power Requirements and LEDs

This module consumes 120 mA from the 5V bus on the PLC backplane and also requires 65 mA plus current loop current(s) from a user supplied +24V supply (see Table 3-13, *Specifications*).

There are two green LED indicators on the module which provide module and user supply status. The top LED, **MODULE OK** provides module status information on power-up as follows:

- *ON*: status is OK, module configured;
- *OFF*: no backplane power or software not running (watchdog timer timed out);
- *Continuous rapid flashing*: configuration data not received from CPU;
- *Slow flashes, then OFF*: failed power-up diagnostics or encountered code execution error.

The bottom LED, **User Supply OK**, indicates that the user provided 24V supply is within specifications, thereby enabling the analog side of the module to work properly.

Location in System

This module can be installed in any I/O slot of a 5 or 10-slot baseplate in a Series 90-30 PLC system.

10

References Used

The number of 16-Channel Analog Current Input modules which may be installed in a system depends on the amount of %AI and %I references available. Each module uses 1 to 16 %AI references (depending on the number of channels enabled) and from 8 to 40 %I (depending on alarm status configuration) references.

The available %AI references are: 64 in a Model 311, Model 313, and Model 323 system, 128 in a Model 331 system, 1024 in a Model 340 and 341 system, and 2048 in a Model 351 and Model 352 system.

The maximum number of 16-Channel Analog Current Input modules which may be installed in a system are:

- 4 in a Model 311, Model 313, and Model 323 system
- 8 in a Model 331 system
- 12 in a Model 340 and Model 341 system
- 51 in a Model 351 and Model 352 system

When planning the module configuration for your application you must also consider the load capacity of the installed power supply and the total load requirements of all modules that are installed in the baseplate.

Refer to the *Series 90-30 Programmable Controller Installation Manual*, GFK-0356 for details on power supplies and module load requirements.

Table 10-7. Specifications for 16-Channel Analog Current Input Module, IC693ALG223

Number of Channels	1 to 16 selectable; single ended
Input Current Ranges	0 to 20 mA, 4 to 20 mA and 4 to 20 mA Enhanced (selectable per channel)
Calibration	Factory calibrated to: 4 µA per count on 4 to 20 mA range 5 µA per count on 0 to 20 mA and 4 to 20 mA Enhanced range
Update Rate	13 msec (all 16 channels)
Resolution at 4-20 mA	4 µA (4 µA/bit)
Resolution at 0-20 mA	5 µA (5 µA/bit)
Resolution at 4-20 mA Enhanced	5 µA (5 µA/bit)
Absolute Accuracy †	± 0.25% of full scale @ 25°C (77°F); ± 0.5% of full scale over specified operating temperature range
Linearity	< 1 LSB from 4 to 20 mA (4 to 20 mA range) < 1 LSB from 100 µA to 20 mA (0 to 20 mA and 4 to 20 mA Enhanced ranges)
Isolation	1500 volts between field side and logic side
Common Mode Voltage	0 volts (single-ended channels)
Cross-Channel Rejection	> 80 db from DC to 1 kHz
Input Impedance	250 ohms
Input Low Pass Filter Response	19 Hz
External Supply Voltage Range	20 to 30 VDC
External Supply Voltage Ripple	10%
Internal Power Consumption	120 mA from the +5 volt bus on the backplane 65 mA from 24 VDC external user supply (in addition to current loop currents)

Refer to data sheet GFK-0867C, or later revision for product standards and general specifications.

† In the presence of severe RF interference (IEC 801-3, 10V/m), accuracy may be degraded to ±5% FS.

CPU Interface to the IC693ALG223 Analog Current Input Module

The Series 90-30 PLC uses the data within the %AI data table to record analog values for use by the programmable controller. This scheme is shown in Figure 3-25 for the 16-Channel Analog Current Input module. *More detailed information on the CPU interface to analog modules can be found at the beginning of this chapter.*

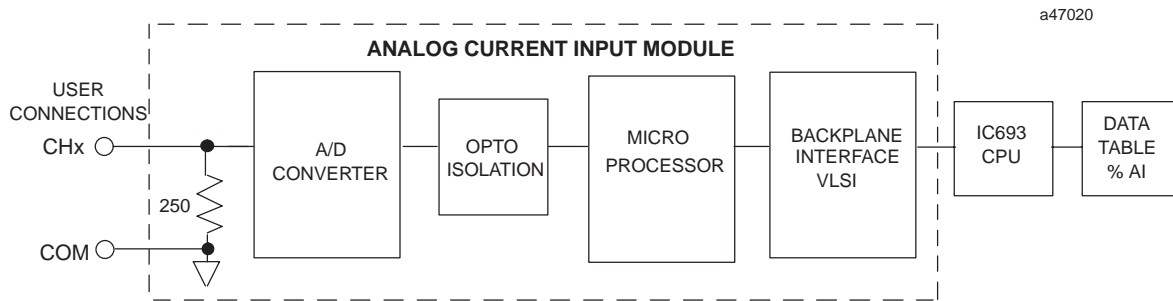

Figure 10-14. 16-Channel Analog Current Input Module Block Diagram - IC693ALG223

Placement of A/D Bits within the Data Tables

Since converters used in the analog modules are 12-bit converters, not all of the 16 bits in the data tables contain data required for the conversion. A version of the 12 bits is placed within the 16-bit data word corresponding to the analog point (in the %AI table). The Series 90-30 PLC system handles the integration differently for the various analog modules.

The CPU does not manipulate the data from the input modules before placing it within the word in the %AI data table. The bits in the %AI data table which were not used in the conversion by the input module are forced to 0 (zero) by the analog input module. Placement of the 12 data bits from the A/D converter for an analog current input data word for the 16-Channel Analog Current Input module is shown below.

MSB												LSB			
X	D11	D10	D9	D8	D7	D6	D5	D4	D3	D2	D1	D0	X	X	X

X=not converted bits

Analog values are scaled over the range of the converter. Factory calibration adjusts the analog value per bit (resolution) to a multiple of full scale (that is, 4 μA/bit). This calibration leaves a normal 12-bit converter with 4000 counts (normally $2^{12} = 4096$ counts). The data is then scaled with the 4000 counts over the analog range. For example, the data to the A/D converter for the 16-Channel Analog Current Input is scaled as shown in the following figure.

10

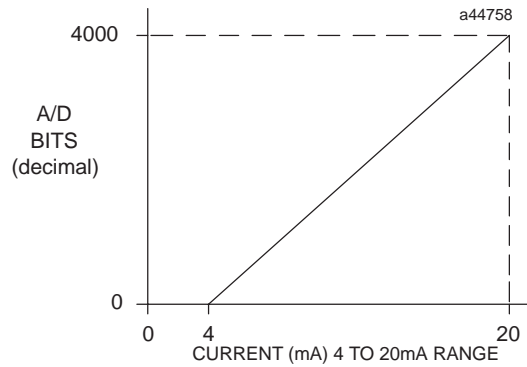

Figure 10-15. A/D Bits vs. Current Input for IC693ALG223

IC693ALG223 Configuration

The 16-Channel Analog Current Input module can be configured using either the Logicmaster 90-30/20/Micro or CIMPLICITY Control Programming Software configurator function, or with the Hand-Held Programmer.

The parameters that may be configured are described in the following table. Configuration procedures using Logicmaster 90-30/20/Micro Programming Software and the Hand-Held Programmer are described in the following pages.

Table 10-8. Configuration Parameters

Parameter Name	Description	Values	Default Values	Units
<i>Active Channels</i>	Number of channels converted	1 through 16	1 (Logicmaster 90-30/20/Micro) 16 (Hand-Held programmer)	n/a
<i>Ref Adr</i>	Starting address for %AI reference type	standard range	%AI0001, or next highest available address	n/a
<i>Ref Adr</i>	Starting address for %I reference type	standard range	%I00001, or next highest available address	n/a
<i>%I Size</i>	Number of %I status locations	8, 16, 24, 32, 40	8 (Logicmaster 90-30/20/Micro) 40 (Hand-Held Programmer)	bits
<i>Range</i>	Type of input and range	4-20, 0-20, or 4-20+ (Enhanced)	4-20	n/a
<i>Alarm Low</i>	Low limit alarm value	-8000 to +32759	0	User counts
<i>Alarm High</i>	High limit alarm value	-7999 to +32760	+32000	User counts

For more information on configuration, see

- *Configuration Using Logicmaster 90-30/20/Micro Programming Software* beginning on page 3-42
- *Configuration Using the Hand-Held Programmer* beginning on page 3-46

Configuring IC693ALG223 Using Logicmaster Software

This section describes how you can configure the 16-Channel High Density Analog Current Input module using the configurator function in Logicmaster 90-30/20/Micro programming software. Configuration can also be done using CIMPLICITY Control Programming Software. For details refer to the CIMPLICITY Control online help.

To configure a 16-Channel Analog Input Module on the I/O Configuration Rack screen:

1. Move the cursor to the slot where the module will be located, and press the **m30 io** softkey (F1). In the following example screen, the module will be placed in slot 5 of the main rack.

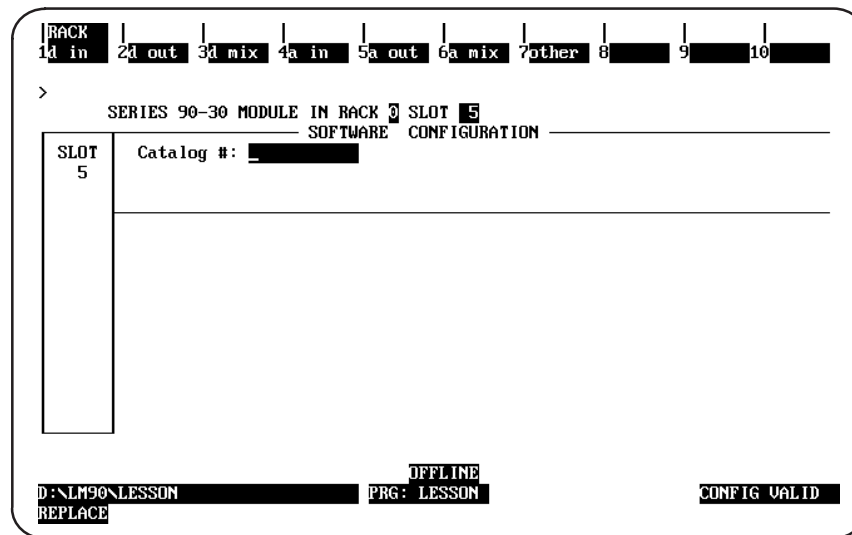

2. Press the **a in**, softkey (F4) to display a list of available analog input modules and their catalog numbers.

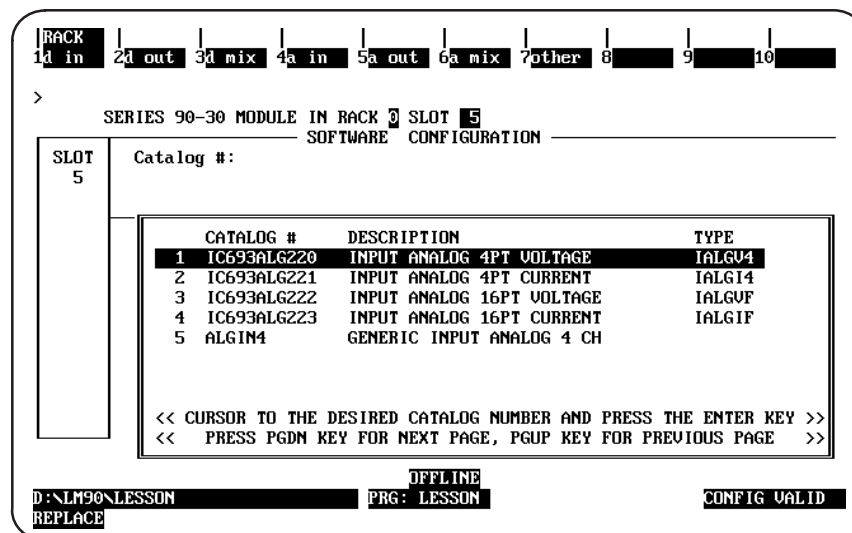

10

- To select the 16-Channel Analog Input Module, position the cursor on the catalog number for the module, IC693ALG223, and press the **Enter** key.

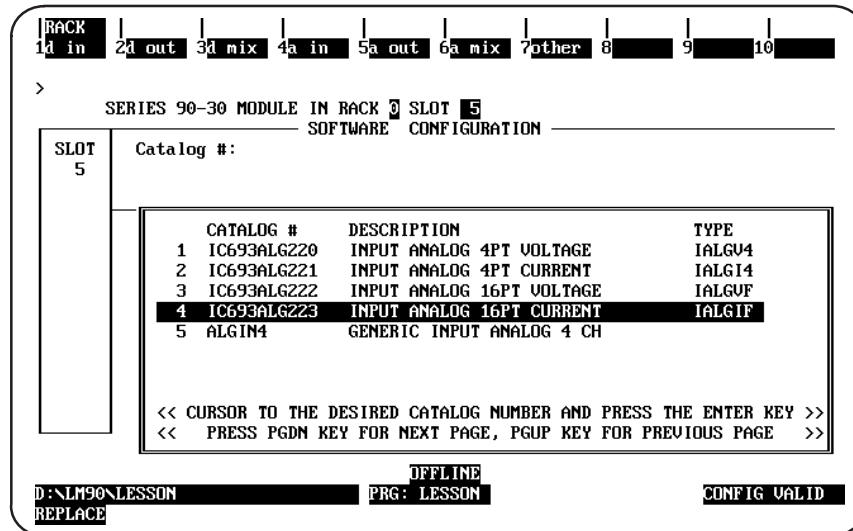

- After pressing the Enter key, the first detail screen, shown below, is displayed.

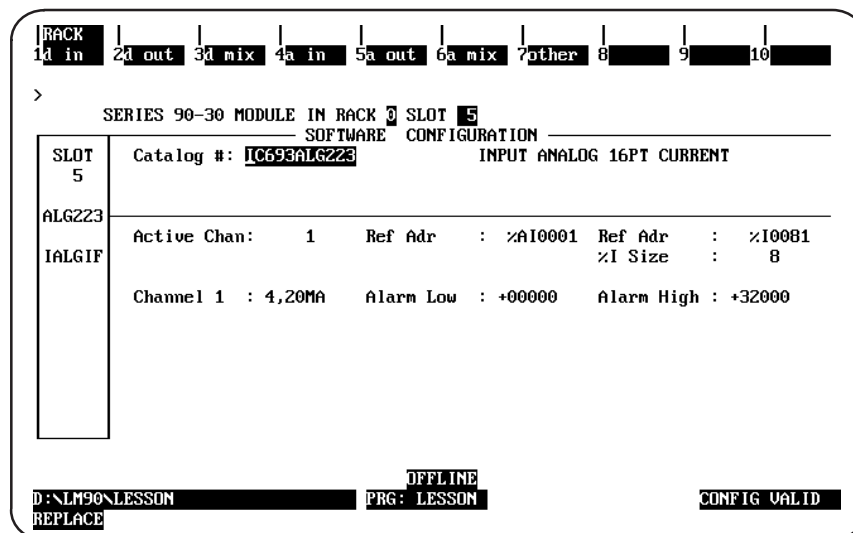

Note

Only enabled (active) channels are displayed on the screen

- Use the parameter descriptions provided in the following table to help you make selections for the parameters on this screen.

Table 10-9. Parameter Descriptions for Configuration

Parameter	Description
Active Channel	Enter a number from 1* through 16. This number represents the number of channels to be converted. Channels are scanned in sequential, contiguous order, with channel No. 1 being the first channel scanned. If more than eight channels are selected, a second detail screen will be displayed to allow you to enter data in channels 9 through 16.
Reference Address	The first Reference Address field contains the reference address for %AI data. The address points to the location in %AI memory where input data to the module begins. Each channel provides 16 bits of analog input data as an integer value from 0 to 32,760 or -8,000 to 32,760, depending on the range type selected.
Reference Address	The second Reference Address field contains the reference address for %I data. The address points to the location in %I memory where status information from the module begins. You can select the number of %I status locations reported to the PLC by editing the value in the %I Size field.
%I Size	Enter the number of %I locations reported to the PLC. Choices are 8, 16, 24, 32, or 40. The data is brought back in the following format:
	First eight %I locations: (available for %I SIZE values 8, 16, 24, 32, and 40)
	<ul style="list-style-type: none"> ● %I = Module OK: 0 = module NOT OK; 1 = module OK. ● %I+1 = User Supply OK: 0 = below limit; 1 = user supply OK. ● %I+2 through %I+7 = Reserved for future modules.
	Second eight %I locations: (available for %I SIZE values 16, 24, 32, and 40)
	<ul style="list-style-type: none"> ● %I+8 = Channel No. 1 ALARM LO 0 = above limit; 1 = below or equal to limit. ● %I+9 = Channel No. 1 ALARM HI: 0 = below limit; 1 = above or equal to limit. ● %I+10 = Channel No. 2 ALARM LO: 0 = above limit; 1 = below or equal to limit. ● %I+11 = Channel No. 2 ALARM HI: 0 = below limit; 1 = above or equal to limit. ● %I+12 = Channel No. 3 ALARM LO: 0 = above limit; 1 = below or equal to limit. ● %I+13 = Channel No. 3 ALARM HI: 0 = below limit; 1 = above or equal to limit. ● %I+14 = Channel No. 4 ALARM LO: 0 = above limit; 1 = below or equal to limit. ● %I+15 = Channel No. 4 ALARM HI: 0 = below limit; 1 = above or equal to limit.
Third eight %I locations: (available for %I SIZE values 24, 32, and 40)	
<ul style="list-style-type: none"> ● %I+16 = Channel No. 5 ALARM LO 0 = above limit; 1 = below or equal to limit. ● %I+17 = Channel No. 5 ALARM HI: 0 = below limit; 1 = above or equal to limit. ● %I+18 = Channel No. 6 ALARM LO: 0 = above limit; 1 = below or equal to limit. ● %I+19 = Channel No. 6 ALARM HI: 0 = below limit; 1 = above or equal to limit. ● %I+20 = Channel No. 7 ALARM LO: 0 = above limit; 1 = below or equal to limit. ● %I+21 = Channel No. 7 ALARM HI: 0 = below limit; 1 = above or equal to limit. ● %I+22 = Channel No. 8 ALARM LO: 0 = above limit; 1 = below or equal to limit. ● %I+23 = Channel No. 8 ALARM HI: 0 = below limit; 1 = above or equal to limit. 	
Fourth eight %I locations: (available for %I SIZE values 32 and 40)	
<ul style="list-style-type: none"> ● %I+24 = Channel No. 9 ALARM LO 0 = above limit; 1 = below or equal to limit. ● %I+25 = Channel No. 9 ALARM HI: 0 = below limit; 1 = above or equal to limit. ● %I+26 = Channel No. 10 ALARM LO: 0 = above limit; 1 = below or equal to limit. ● %I+27 = Channel No. 10 ALARM HI: 0 = below limit; 1 = above or equal to limit. ● %I+28 = Channel No. 11 ALARM LO: 0 = above limit; 1 = below or equal to limit. ● %I+29 = Channel No. 11 ALARM HI: 0 = below limit; 1 = above or equal to limit. ● %I+30 = Channel No. 12 ALARM LO: 0 = above limit; 1 = below or equal to limit. ● %I+31 = Channel No. 12 ALARM HI: 0 = below limit; 1 = above or equal to limit. 	

Table 10–9. Parameter Descriptions for Configuration (continued)

Parameter	Description
%I Size (cont'd)	<p><u>Fifth eight %I locations:</u> (available for %I SIZE value 40)</p> <ul style="list-style-type: none"> ● %I+32 = Channel No. 13 ALARM LO 0 = above limit; 1 = below or equal to limit. ● %I+33 = Channel No. 13 ALARM HI: 0 = below limit; 1 = above or equal to limit. ● %I+34 = Channel No. 14 ALARM LO: 0 = above limit; 1 = below or equal to limit. ● %I+35 = Channel No. 14 ALARM HI: 0 = below limit; 1 = above or equal to limit. ● %I+36 = Channel No. 15 ALARM LO: 0 = above limit; 1 = below or equal to limit. ● %I+37 = Channel No. 15 ALARM HI: 0 = below limit; 1 = above or equal to limit. ● %I+38 = Channel No. 16 ALARM LO: 0 = above limit; 1 = below or equal to limit. ● %I+39 = Channel No. 16 ALARM HI: 0 = below limit; 1 = above or equal to limit.
Range	<p>Select the type of input range and the ranges. Choices are 4 -20mA,* 0-20mA, or 4-20mA+.</p> <p>In the 4 to 20mA default range, input current values ranging from 4 to 20mA report 0 to 32,000 integer values to the CPU. In the 0 to 20mA range, input current values ranging from 0 to 20mA report 0 to 32,000 integer values to the CPU over an input current range of 0 to 20mA.</p> <p>The enhanced 4 to 20mA range operates like the default 4 to 20mA range, except that negative values are reported when the input current drops below 4mA. In this mode, if 0mA is input, the value reported to the PLC is -8,000.</p>
Alarm Low	<p>Enter a value that causes an alarm low indication to be passed to the PLC. Each channel has a low limit alarm value (ALARM LO), which causes %I points to be set. Values entered without a sign are assumed to be positive. Value checking should be done to determine if the alarm low values are allowed for the appropriate range. The values allowed are:</p> <ul style="list-style-type: none"> ● 4 to 20mA Range = 0 to 32759 ● 0 to 20mA Range = 0 to 32759 ● 4 to 20mA+ Range = -8,000 to +32759
Alarm High	<p>Enter a value that causes an alarm high indication to be passed to the PLC. Each channel has a high limit alarm value (ALARM HI), which causes %I points to be set. Values entered without a sign are assumed to be positive. Value checking should be done to determine if the alarm high values are allowed for the appropriate range. The values allowed are:</p> <ul style="list-style-type: none"> ● 4 to 20mA Range = 1 to 32760 ● 0 to 20mA Range = 1 to 32760 ● 4 to 20mA+ Range = -7999 to 32760

* Default selection.

6. Press Rack (Shift-F1) or the Escape key to return to the rack display.

Configuring IC693ALG223 Using Hand-Held Programmer

You can also configure the 16-Channel Analog Current Input module using the Series 90-30 Hand-Held Programmer. In addition to the information in this section, refer to GFK-0402, the *Hand-Held Programmer for Series 90-30/20/Micro Programmable Controllers User's Manual* for more information on configuration of Intelligent I/O modules.

Although you can change the number of actively scanned channels with the Logicmaster 90-30/20/Micro configurator function, the Hand-Held Programmer does not support editing the number of actively scanned channels. If the 16-Channel Analog Input module is initialized by a Hand-Held Programmer, the number of actively scanned channels is 16.

If a module had been previously configured with Logicmaster 90-30/20/Micro software and the number of actively scanned channels has been changed from 16, that number will be displayed on the bottom line of the Hand-Held Programmer display following the *AI*. You can edit data with the Hand-Held Programmer only for the active channels, but can not change the number of actively scanned channels.

Module Present

If a module is physically present in a system, it can be added to the system's configuration by *reading* the module into it. For example, assume that a 16-Channel Analog Current Input module is installed in slot 3 of a Model 311 PLC system. It can be added to the configuration with the following sequence. Use the Up and Down cursor keys or the # key to display the selected slot.

Initial Display

```
R0:03 EMPTY >S
```

To add the IC693ALG223 module to the configuration, press the **READ/VERIFY** key. The following screen will be displayed:

```
R0:03 HI-DEN C >S
I40:I_
```

Selecting %I Reference

At this point the starting %I reference address for the status data returned from the module must be entered. Notice that the length of the status field (**40**) is displayed as the first two digits following the first **I** on the second line of the display.

10

Note

This field cannot be changed with the Hand-Held programmer. However, it can be changed using the Logicmaster 90-30/20/20/Micro software configurator function. The Hand-Held Programmer will always reflect the currently active length of the status field.

Pressing the **ENT** key will allow the PLC to select the starting address of the status data. You can select a specific starting address by pressing the key sequence for the desired address and pressing the **ENT** key. For example to specify the starting address as I17, press the key sequence **1, 7, ENT**. The following screen will be displayed:

```
R0:03 HI-DEN C >S
I40:I17-I56
```

Selecting %AI Reference

After the starting %I address has been selected, pressing the **ENT** key again will cause the following screen to be displayed:

```
R0:03 HI-DEN C >S
AI16:AI_
```

This screen allows you to select the starting address for the %AI reference. Note that the length of the status field (**16**) is displayed as the first two digits following the first **AI** on the second line of the display.

Note

This field cannot be changed with the Hand-Held programmer. However, it can be changed using the Logicmaster 90-30/20/Micro software configurator function. The Hand-Held Programmer will always reflect the currently active length of the status field.

In the AI field you can select the next available address (the default) by pressing the **ENT** key or by entering a specific address. To enter a specific address, press the starting reference number keys and the **ENT**. key (for example **3, 5**, then **ENT**).

```
R0:03 HI-DEN C >S
AI16:AI035-AI051
```

You can press the **CLR** key at any time to abort the configuration you have just selected and return the slot to *EMPTY*.

Removing Module From Configuration

If required, this module can be removed from the current configuration. Assume that the module is currently configured in rack 0, slot 3. It can be deleted with the following sequence:

Initial Display

```
R0:03 HI-DEN C >S
AI16:AI_
```

To delete the module, press the **DEL**, **ENT** key sequence. The display will then be:

```
R0:03 EMPTY >S
```

Selecting Input Channel Ranges

The range for each of the 16 channels can be displayed and selected or changed as described below. Assume that the %AI address is as previously selected.

initial display

```
R0:03 HI-DEN C >S
AI16:AI035-AI051
```

To display the channel ranges press the **→** key. The display will show Channel 1 (or the currently selected channel) and the first available range.

```
R0:03 HI-DEN C >S
CHANNEL 1: 4-20
```

You can toggle through the range for each channel by pressing the **±** key. Each range will be displayed as shown. The range selected is the one currently displayed.

```
R0:03 HI-DEN C >S
CHANNEL 1: 0-20
```

```
R0:03 HI-DEN C >S
CHANNEL 1: 4-20+
```

Alarm Limits Display

To view the alarm limits for the channel currently displayed, press the **→** key again (the first time caused the channel ranges to be available for editing). The following screen is displayed:

10

```
R0:03 HI-DEN C >S
CHAN 1 LO: 00000
```

The display is the entry field for the low alarm limit for the displayed channel (in this case, Channel 1). You can enter the desired low alarm limit value using the numeric keys and the \pm key for specifying negative values. Enter the low alarm limit using a value within the valid limits as listed in Table 2. After you have entered the low alarm limit value, press the \rightarrow key again to advance to the high alarm limit display for this channel. The following screen is displayed at this time.

```
R0:03 HI-DEN C >S
CHAN 1 HI: 32000
```

The display shows the entry field for the high alarm limit for the currently displayed channel. You can enter positive or negative numbers (see table 2) using the \pm and numeric keys. After selecting the low and high alarm limits for channel 1 (or the currently displayed channel), you can view the next channel by pressing the \rightarrow key.

```
R0:03 HI-DEN C >S
CHANNEL 2: 4-20
```

Edit the range, and low and high alarm limits as described for Channel 1. All active channels can be changed in this manner. Return to the initial display screen by pressing the **ENT** key or by pressing the \leftarrow key until the initial screen is displayed.

Saved Configurations

Configurations that contain a 16-Channel Analog Current Input module can be saved to an EEPROM or MEM card and read into the CPU at a later time. MEM cards and EEPROMs containing these configurations can be read into any Release 4 or later CPU. Refer to Chapter 2 of the *Hand-Held Programmer User's Manual* for detailed information on the Save and Restore operations.

IC693ACC223 Analog Module Field Wiring Connections

Connections to this module from user devices are made to screw terminals on a removable 20-terminal connector block mounted on the front of the module. The actual terminals used are described in the following table and are shown in the following wiring diagrams.

Terminal Assignments

Pin assignments for the 20 terminal I/O connector on the 16-Channel Analog Current Input module are as shown in the following table.

Table 10-10. Terminal Pin Assignments

Pin Number	Signal Name	Signal Definition
1	24VIN	User supplied 24V Input; provides loop power via 24VOUT terminal (pin 2)
2	24VOUT	+24V loop power tie point
3	CH1	Current Input, Channel 1
4	CH2	Current Input, Channel 2
5	CH3	Current Input, Channel 3
6	CH4	Current Input, Channel 4
7	CH5	Current Input, Channel 5
8	CH6	Current Input, Channel 6
9	CH7	Current Input, Channel 7
10	CH8	Current Input, Channel 8
11	CH9	Current Input, Channel 9
12	CH10	Current Input, Channel 10
13	CH11	Current Input, Channel 11
14	CH12	Current Input, Channel 12
15	CH13	Current Input, Channel 13
16	CH14	Current Input, Channel 14
17	CH15	Current Input, Channel 15
18	CH16	Current Input, Channel 16
19	COM	Common connection to input current sense resistors; user supplied 24V input return or 24VIN return
20	GND	Frame ground connections for cable shields

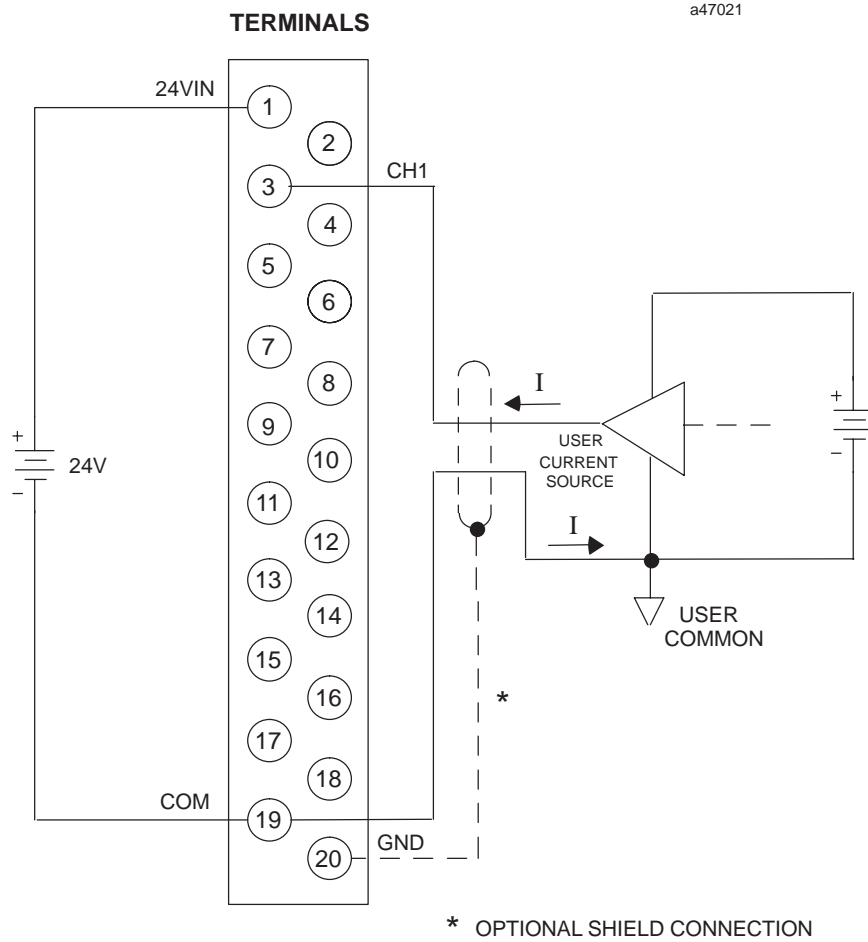

Figure 10-17. Field Wiring - Alternate User Connections - IC693ALG223

Note

Please refer to Chapter 2 for wiring and shield ground connection details.

10

IC693ACC223 Analog Current Input Block Diagram

The following figure is a block diagram of the 16-Channel Analog Current Input Module.

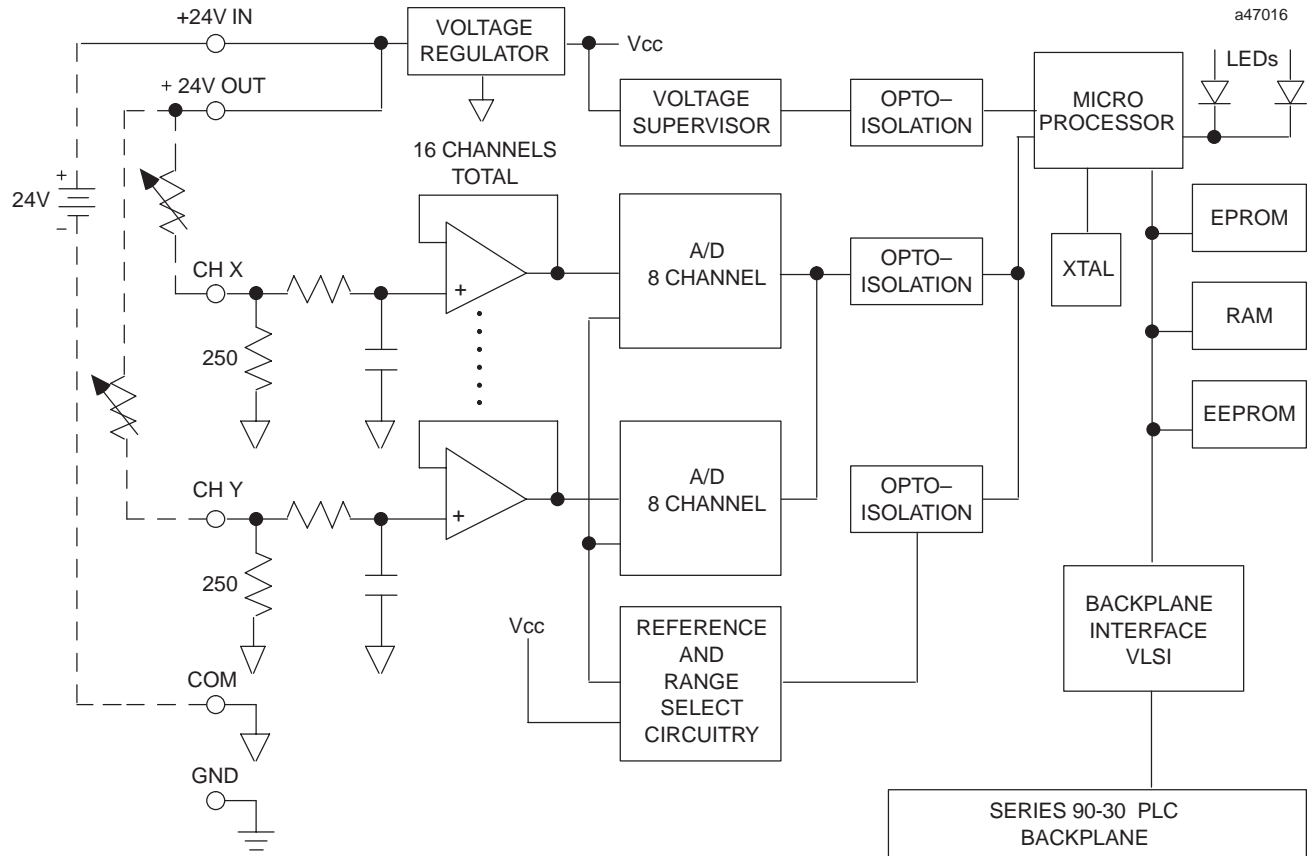

Figure 10-18. 16-Channel Analog Current Input Module Block Diagram - IC693ALG223

CONTACT US & SUPPORT

NEED A QUOTE OR TECHNICAL PARTS REPLACEMENT?

Company: [PLC ProTech Ltd.](#)
Website: www.plcprotech.com
Email: sales@plcprotech.com
Phone: +86 180 4631 7198

Our Service Guarantee:

- 100% Brand New Original & Factory Sealed Components
- 12-Month Quality Warranty on All Industrial Parts
- Worldwide Same-Day Fast Dispatch via DHL / FedEx

[SUBMIT ONLINE RFQ \(REQUEST FOR QUOTE\) >>](#)

[About Us](#) · [Contact](#) · [All Products](#)