

# PLC ProTech Ltd.

Industrial Automation Components

## TECHNICAL DOCUMENTATION

### SYSTEM INTEGRATION & REPLACEMENT SUPPORT GUIDE

---

PLC ProTech Ltd. stands at the intersection of complex industrial challenges and high-performance solutions. As a premier global supplier, we specialize in delivering 100% Brand New, factory-sealed components from world-leading brands including ABB, GE, and Honeywell. We maintain an extensive inventory of hard-to-find and discontinued PLC/DCS modules, offering Same-Day Dispatch to over 150 countries. Backed by a 12-month warranty, we empower your operations with technical integrity and peace of mind.

[GET INSTANT QUOTE & INVENTORY STATUS >>](#)

## Analog Current Output - 2 Channel IC693ALG391

The **2-Channel Analog Current Output** module for the Series 90-30 Programmable Logic Controller provides two output channels, each capable of converting 12 bits of binary (digital) data to an analog output for use as required by your application. The Analog Current Output module is capable of providing outputs in the range of 0 to 20 mA. Resolution of the converted signal is 12 bits binary (1 part in 4096). The sign bit is not used in the conversion process. Both channels are updated on every scan (about 5 milliseconds). User data in the %AQ registers is in a 16-bit 2's complement format. The 13 most significant bits from the %AQ register are converted to sign magnitude by the PLC and sent to the module. Twelve of the bits are used by the D/A converter; the 13th bit (sign) is used to determine if negative data was sent to the module.

The placement of the 13 bits within the data word is shown below. The relationship between the current output and the data from the D/A converter is shown in Figures 3-34 and 3-35.

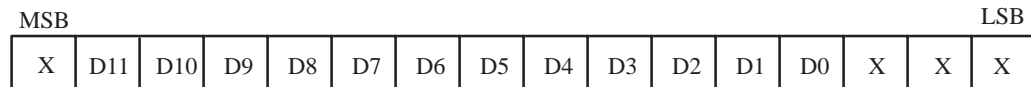

S = sign bits  
X = not applicable to this discussion.

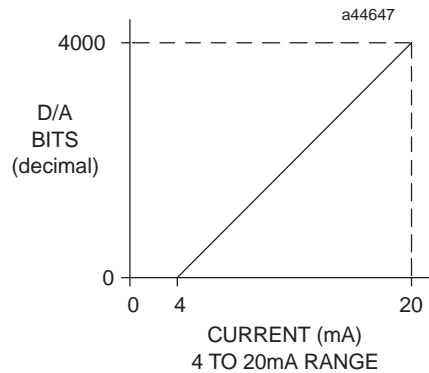

**Figure 11-5. D/A Bits vs. Current Output, 4 to 20 mA**

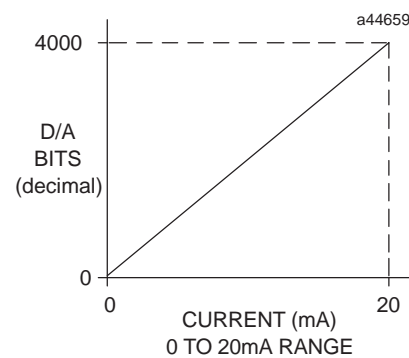

**Figure 11-6. D/A Bits vs. Current Output, 0 to 20 mA**

If the module is sent negative data, it outputs the low end of the current range (that is, 4 mA for the 4 to 20 mA range). If a value which is out of range is entered (that is, greater than 32767), the software does not accept the value.

This module provides two output ranges. The default range is 4 to 20 mA with user data scaled so that a count of 0 corresponds to 4 mA and a count of 32000 corresponds to 20 mA with each 1000 counts representing 0.5 mA. When a RANGE jumper (either RANGE1 or RANGE2) is added to the I/O terminal board, the output range is 0 to 20 mA with user data scaled so that a count of 0 corresponds to 0 mA and a count of 32000 corresponds to 20 mA with each 800 counts representing 0.5 mA. The range of each output can be programmed individually. The module provides a full 12 bits of resolution in either range. Scaling of the output is as shown in Figures 3-36 and 3-37.

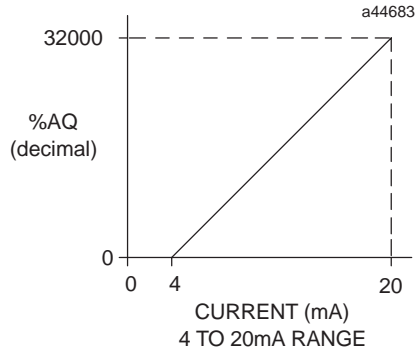

**Figure 11-7. Scaling for Current Output, 4 to 20 mA**

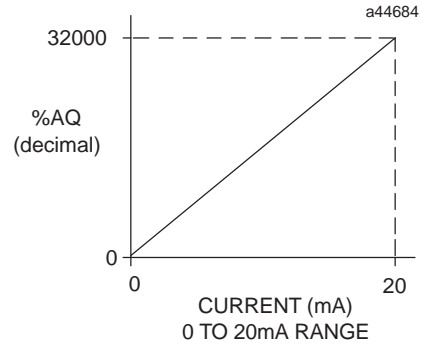

**Figure 11-8. Scaling for Current Output, 0 to 20 mA**

The state of the module if the CPU goes to the STOP mode or RESET, can be either *Default to 0/4 mA* or *Hold-Last-State*. Selection of the desired state is made by configuring the DEF0/4 jumper on the detachable terminal board connector on the module. If the jumper is not installed, the outputs will Hold-Last-State on STOP or RESET provided that a backup user supply is connected when the system power goes down. If the DEF0/4 jumper is present, the module defaults to 4 mA on the 4 to 20 mA range or 0 mA on the 0 to 20 mA range on STOP or RESET. One jumper per module is used to program both outputs for Hold-Last-State or DEF0/4.

Each module output may be used as a current source or as a less accurate voltage source. A voltage is output at VOUTx that corresponds to the current output. The selection of current or voltage output is made with a jumper on the I/O terminal board. If no jumper is installed, the module performs as a current source. If the JMPVx jumper is present, the module performs as a voltage source. Each channel has the option of selecting voltage or current. The setting of the current output range determines the voltage range. The voltage range can be increased by using a 250 ohm resistor in place of the voltage jumper from JMPVx to IOUTx. The following table shows the relationship between range settings and voltage outputs.

**Table 11-2. Range Settings vs. Voltage Outputs**

Range Setting	Voltage Range
4 to 20 mA (no range jumper)	1 to 5 V 2 to 10 V with external resistor
0 to 20 mA (range jumper present)	0 to 5 V 0 to 10 V with external resistor

The primary power source for the module is the isolated +24 VDC power supplied by the PLC power supply. Two terminals are also provided on the module's I/O terminal board for user supplied +24 volts. This allows you to provide a standby power supply so that the outputs can continue to hold their value if the internal supply is lost and Hold-Last-State is selected. You may also want to supply the module voltage to reduce the load on the PLC isolated +24 VDC power supply. The user supply will be used when the applied voltage is higher than the isolated +24 VDC supply, which can range from 21.5 volts to 26.5 volts.

An internal voltage source of about +24V is generated in the module to drive the current loop outputs. The current loop drivers on the module are source type drivers. This means that a positive current flows out of the current loop outputs so that the user's loads can be returned to common. A resistor is placed in series with the common return to limit ground loop currents. To minimize the

capacitive loading and noise, all field connections to the module should be wired using a good grade of twisted, shielded instrumentation cable. The shields should be connected to GND on the user terminal connector block. The GND connection provides access to the baseplate (frame ground) resulting in superior rejection of noise caused by any shield drain currents.

An LED on the module’s faceplate is ON when the module’s power supply is operating. The module provides electrical isolation of externally generated noise between field wiring and the backplane through use of optical isolation. This module can be installed in any I/O slot of a 5 or 10-slot baseplate in a Series 90-30 PLC system. If user provided supplies are not used to power the module, a maximum of three Analog Current Output modules can be installed in a baseplate.

**Table 11-3. Specifications for Analog Current Output Module - IC693ALG391**

<b>Output Current Range</b>	4 to 20 mA and 0 to 20 mA
<b>Output Voltage Range <sup>1</sup></b>	1 to 5 V and 0 to 5 V
<b>Calibration</b>	Factory calibrated to 4µA per count
<b>Supply Voltage (nominal)</b>	+24 VDC, from isolated +24 VDC on backplane or user supplied voltage source, and +5 VDC from backplane
<b>External Supply Voltage Range <sup>2</sup></b>	20 to 30 VDC
<b>External Supply Voltage Ripple</b>	10%
<b>Update Rate</b>	5 msec (approximate, both channels) <i>Determined by I/O scan time, and is application dependent.</i>
<b>Resolution:</b>	
<b>4 to 20 mA</b>	4µA (1 LSB = 4µA)
<b>0 to 20 mA</b>	5µA (1 LSB = 5µA)
<b>1 to 5 V</b>	1 mV (1 LSB = 1 mV)
<b>0 to 5 V</b>	1.25 mV (1 LSB = 1.25 mV)
<b>Absolute Accuracy: <sup>3</sup></b>	
<b>4 to 20 mA</b>	±8µA at 25°C (77°F)
<b>0 to 20 mA</b>	±10µA at 25°C (77°F)
<b>1 to 5 V</b>	±50 mV at 25°C (77°F)
<b>0 to 5 V</b>	±50 mV at 25°C (77°F)
<b>Maximum Compliance Voltage</b>	25 V
<b>User Load (current mode)</b>	0 to 850 ohms
<b>Output Load Capacitance (current mode)</b>	2000 pF
<b>Output Load Inductance (current mode)</b>	1 H
<b>Maximum Output Loading (voltage mode)</b>	5 mA (2K ohms minimum resistance) (2000 pF maximum capacitance)
<b>Isolation</b>	1500 volts between field and logic side
<b>Internal Power Consumption</b>	30 mA from +5V supply 215 mA from Isolated +24 VDC backplane supply or user supply

**Refer to Appendix B for product standards and general specifications.**

<sup>1</sup> Allowable load on the voltage output option can be calculated from the total module current shown in Figure 3-38.

<sup>2</sup> Allowable user supply is dependent on the current load and the ambient temperature as shown in Figure 3-38.

<sup>3</sup> In the presence of severe RF interference (IEC 801-3, 10V/m), accuracy may be degraded to 10 µA (4 to 20 mA range), 10 µA (0 to 20 mA range).

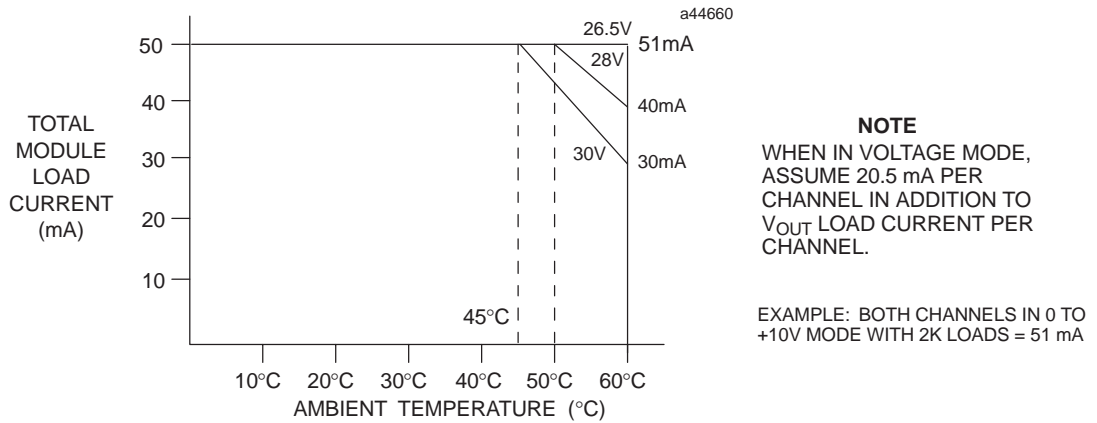

Figure 11-9. Load Current Derating

### IC693ALG391 Analog Current Output Block Diagram

The following figure is a block diagram of the 2-channel Analog Output module.

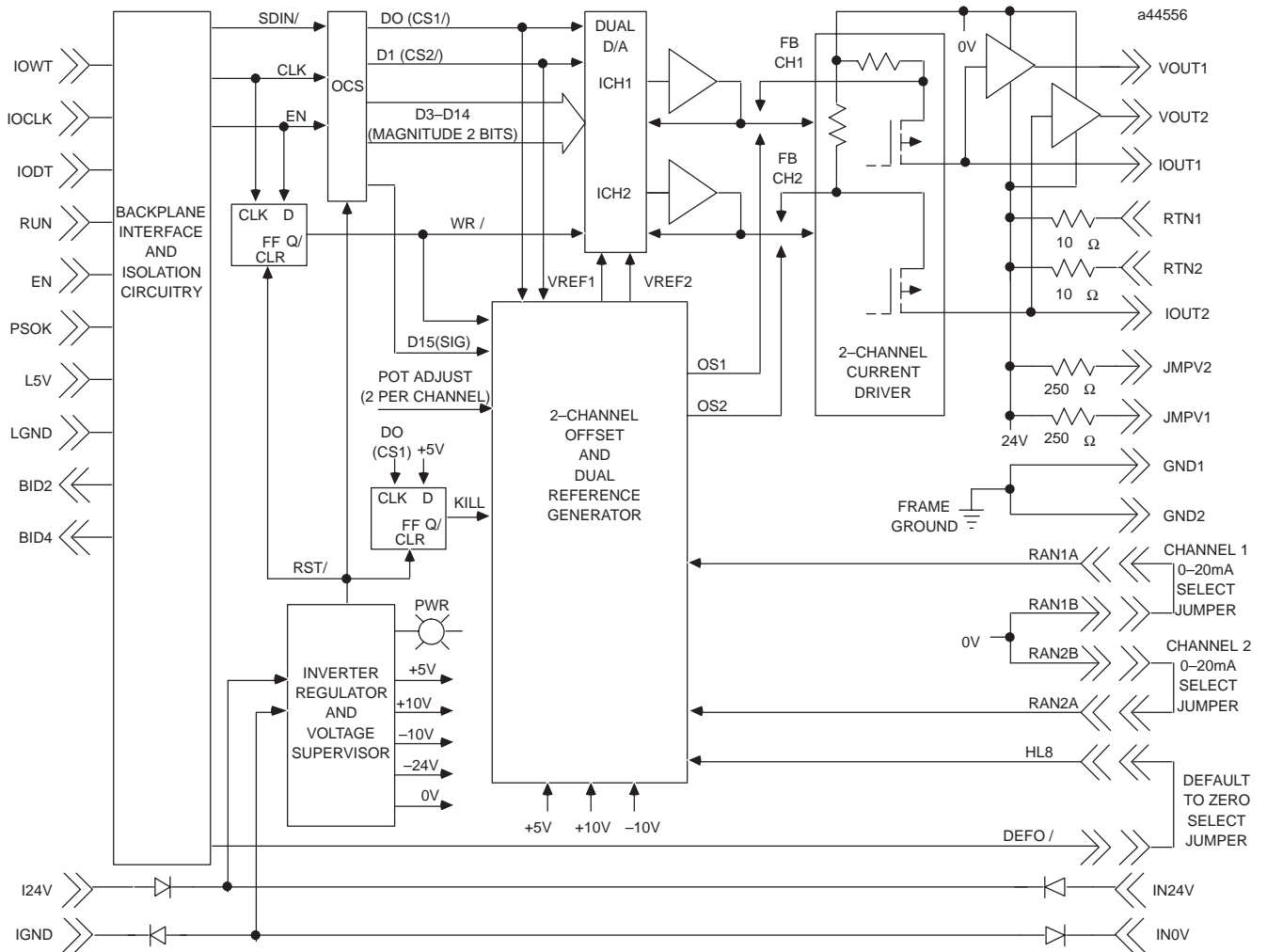
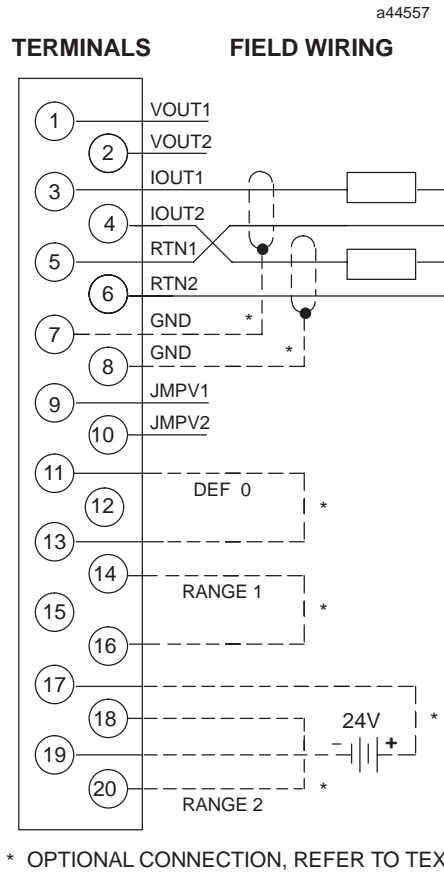

Figure 11-10. Analog Current Output Module Block Diagram - IC693ALG391

## IC693ALG391 Analog Output Module Field Wiring Diagrams

The following two figures provide information for connecting field wiring to the Analog Current Output module. Figure 3-40 shows the connections necessary for the outputs to be used as analog current outputs.



**Figure 11-11. Field Wiring - Analog Current Output Module (Current Mode) - IC693ALG391**

### Note

An external supply can be used to power the module and the loop current.

**Please refer to Chapter 2 for wiring and shield ground connection details.**

Figure 3-41 shows the connections necessary for the outputs of the module to be used as analog voltage outputs.

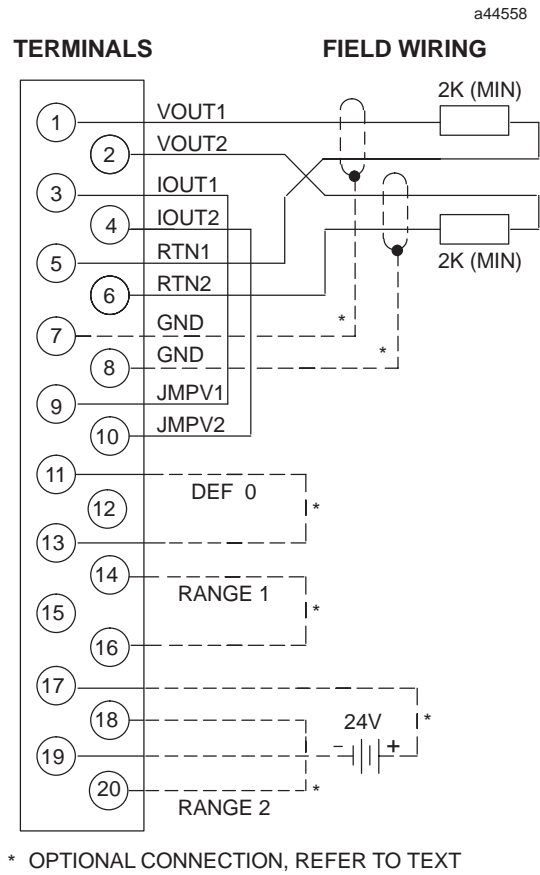

**Figure 11-12. Field Wiring - Analog Current Output Module (Voltage Mode) - IC693ALG391**

**Note**

Please refer to Chapter 2 for wiring and shield ground connection details.

# CONTACT US & SUPPORT

NEED A QUOTE OR TECHNICAL PARTS REPLACEMENT?

---

**Company Name:** [PLC ProTech Ltd.](#)

**Online Support:** [www.plcprotech.com](http://www.plcprotech.com) (Click to Visit)

**Inquiry Email:** [sales@plcprotech.com](mailto:sales@plcprotech.com)

**Direct Hotline:** +86 18046317198

## Our Service Guarantee:

- 100% Brand New Original & Factory Sealed Components
- 12-Month Quality Warranty on All Industrial Parts
- Worldwide Same-Day Fast Dispatch via DHL / FedEx

[SUBMIT ONLINE RFQ \(REQUEST FOR QUOTE\) >>](#)