

Multi-Purpose Power Supply, 24 VDC, 40 Watt: IC695PSD140

Power Supply IC695PSD140 is a multi-purpose 40-Watt supply that operates from an input voltage source in the range of 18 VDC to 30 VDC.

This power supply provides three outputs:

- +5.1 VDC output
- +24 VDC relay output that can be used to power circuits on Output Relay modules
- +3.3 VDC. This output is used internally by RX3i modules with IC695 catalog numbers

Multipurpose Power Supply IC695PSD140 is suitable for use in load-sharing and redundancy application. It must be installed in a PACSystems RX3i (IC695 catalog number) Universal Backplane. It can be used as the only power supply in the backplane, or combined with up to three additional Multipurpose Power Supplies.

Caution

This Power Supply cannot be used with RX3i IC695PSD040 or IC695PSA040 Power Supplies in redundant or increased capacity modes. Damage to equipment may result.

The Power Supply indicates when an internal fault occurs so the CPU can detect loss of power or log the appropriate fault code.



LEDs

Four LEDs on the Power Supply indicate:

- Power (Green/Amber). When this LED is green, it indicates power is being supplied to the backplane. When this LED is amber, power is applied to the Power Supply but the Power Supply switch is off.
- P/S Fault (Red). When this LED is lit, it indicates the Power Supply has failed and is no longer supplying sufficient voltage to the backplane.
- Over Temperature (Amber). When this LED is lit, it indicates the Power Supply is near or exceeding its maximum operating temperature.
- Overload (Amber). When this LED is lit, it indicates the Power Supply is near or exceeding its maximum output capability on at least one of its outputs.

If the red P/S FAULT LED is lit, the Power Supply has failed and is no longer supplying sufficient voltage to the backplane .

The amber OVERTEMP and OVERLOAD LEDs light to warn of high temperature or high load conditions.

The CPU Fault Table shows a fault if any Overtemperature, Overload, or P/S Fault occurs.

Wiring Terminals

Terminals for +24V and –24V power, ground, and MOV disconnect accept individual 14 to 22 AWG wires.

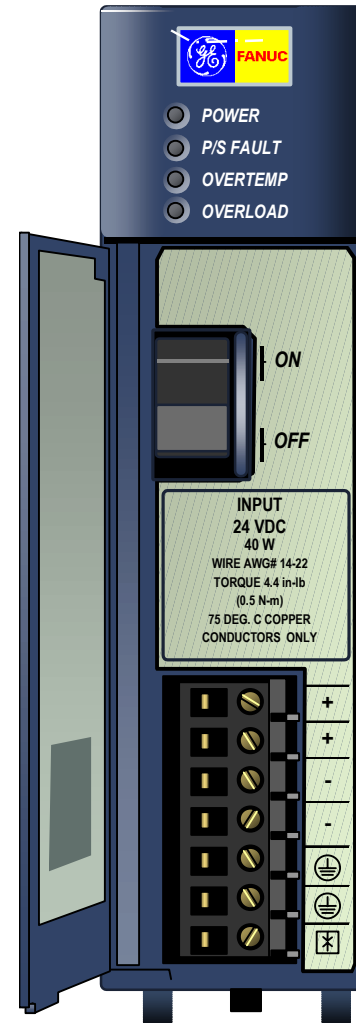

On/Off Switch

The ON/OFF switch is located behind the door on the front of the module. The switch controls the operation of the outputs of the supply. It does NOT interrupt line power. A projecting tab next to the switch helps prevent accidentally turning it on or off.

Specifications: IC695PSD140

Nominal Rated Voltage	24 VDC
Input Voltage Range	18 to 30 VDC
Input Power	60 Watts maximum at full load
Inrush Current	4 Amps, 100 milliseconds maximum *
Output Power	40 Watts maximum total of both outputs. 5.1 VDC = 30 Watts maximum 3.3 VDC = 30 Watts maximum Maximum output power depends on ambient temperature, as shown.
Output Voltage	5.1 VDC: 5.0 VDC to 5.2 VDC (5.1 VDC nominal) 3.3 VDC: 3.1 VDC to 3.5 VDC (3.3 VDC nominal)
Output Current	5.1 VDC: 0 to 6 Amps 3.3 VDC: 0 to 9 Amps
Isolation	NONE
Ripple (all outputs)	50 mV
Noise (all outputs)	50 mV
Ride-through time	10 ms This is the length of time the Power Supply maintains valid outputs if the power source is interrupted. If this Power Supply is used with IC694 and IC693 modules that have relay outputs, special precautions should be taken because dropouts in the source voltage will be seen by the module and may cause relay dropouts.
Wiring Terminals	Each terminal accepts one 14 AWG to 24 AWG wire.
Terminal Current	6 Amps
Number of Daisy-Chain PSD140 Supplies	Up to 4
Number of PSD140 Supplies in Universal Backplane	Up to 4

* The Inrush Current specification is given as a guide for sizing the external power source for the IC695PSD140. Peak inrush current may be higher for shorter durations.

4

Thermal Deratings: PSD140

The maximum output power for Power Supply PSD140 depends on the ambient temperature, as shown below. Full output power is available up to at least 40°C (89.6°F).

5.1 Volt Fully-Loaded

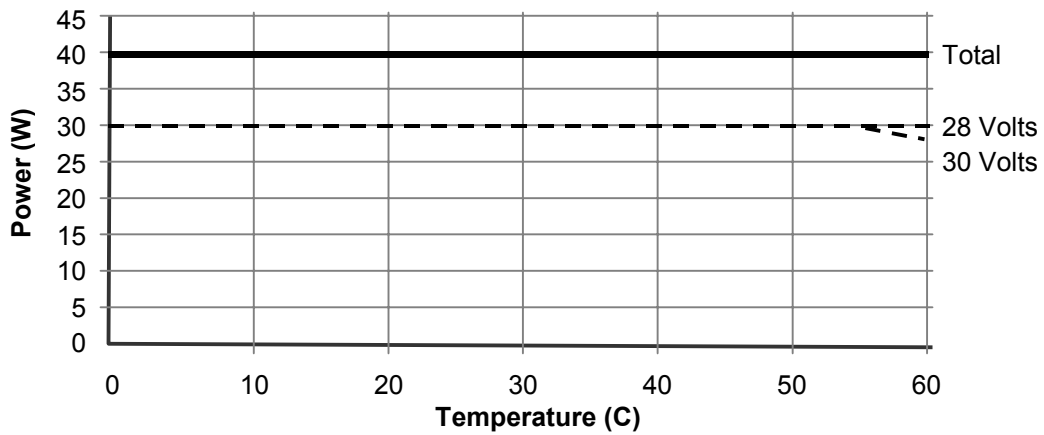

3.3 Volt Fully Loaded

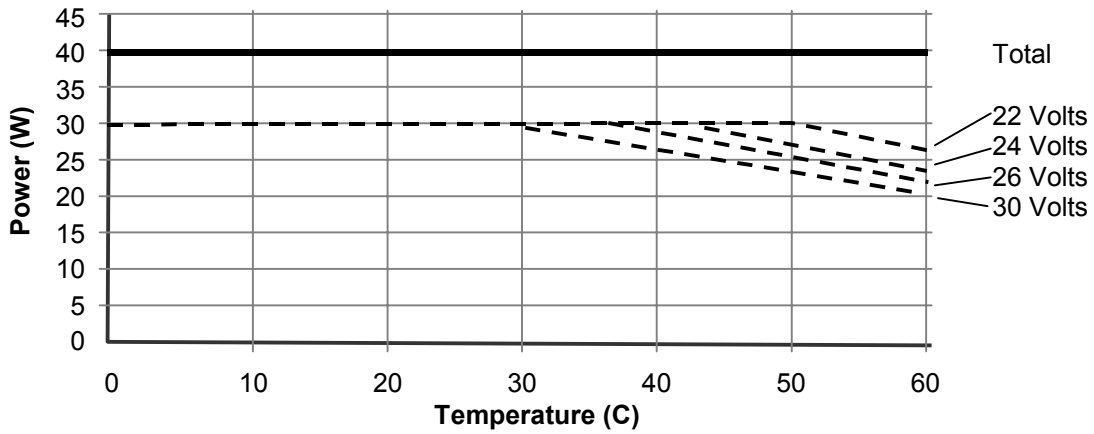

Overcurrent Protection

The 5.1 VDC output is electronically limited to 7 Amps. The 3.3 VDC output is limited to 10 Amps. If an overload (including short circuits) occurs, it is sensed internally and the Power Supply shuts down. Because it is designed for redundancy applications, this Power Supply latches “OFF” in fault conditions and will not automatically try to restart. Input power must be cycled to clear a latched fault.

An internal fusible link in the input line is provided as a backup. The Power Supply usually shuts down before the fusible link blows. The fusible link also protects against internal supply faults. The CPU Fault Table shows a fault if any Overtemperature, Overload, or P/S Fault occurs. There is no additional indication if the Power Supply fusible link blows.

In a non-redundancy application, where automatic restarting may be appropriate, a shunt can be installed on back of the module as shown at left. The shunt must have 0.100 inch spacing on center and accommodate 0.25 inch pins. Example parts are Radio Shack DIP Programming Shunt #276-1512 and DIGI-Key #59000-ND. The module must be removed from the backplane to install the shunt.

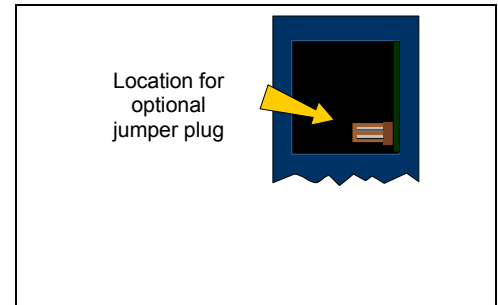

4

Field Wiring: IC695PSD140

Power Source and Ground Connections

The wires from the power source and ground connect to the terminals on the Power Supply as shown at right. Each terminal accepts one AWG 14 to AWG 24 wire.

Warning

If the same external DC power source is used to provide power to two or more power supplies in the system, connection polarity must be identical at each RX3i power supply. A resulting difference in potential can injure personnel or cause damage to equipment. Also, each backplane must be connected to a common system ground.

Input Overvoltage Protection

The bottom terminal is normally connected to frame ground with a user-installed jumper as shown at lower right. If overvoltage protection is not required or is supplied upstream, no jumper is required.

To Hi-pot test this supply, overvoltage protection must be disabled during the test by removing the jumper. Re-enable overvoltage protection after testing by reinstalling the jumper.

Warning

This power supply is not isolated and is therefore not compatible with floating or positive grounded systems.

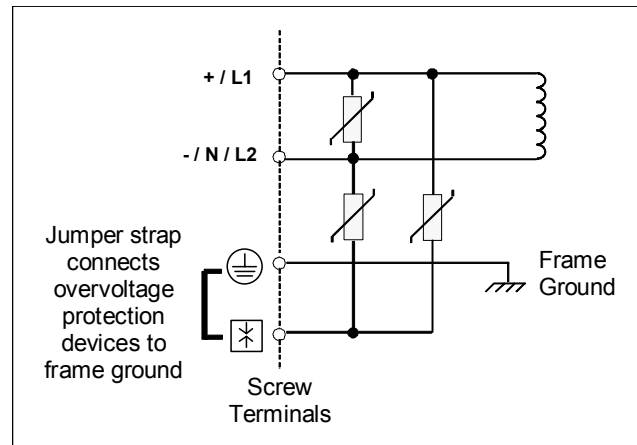
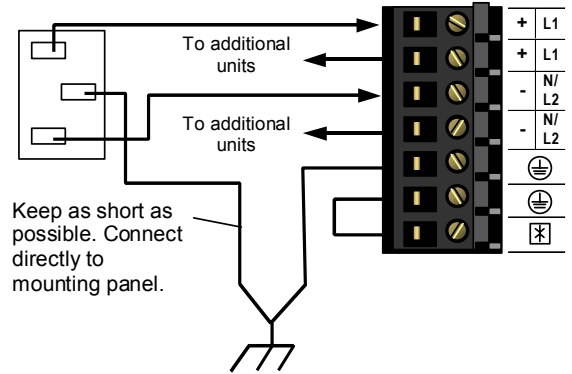

CONTACT US & SUPPORT

NEED A QUOTE OR TECHNICAL PARTS REPLACEMENT?

Company: [PLC ProTech Ltd.](#)
Website: www.plcprotech.com
Email: sales@plcprotech.com
Phone: +86 180 4631 7198

Our Service Guarantee:

- 100% Brand New Original & Factory Sealed Components
- 12-Month Quality Warranty on All Industrial Parts
- Worldwide Same-Day Fast Dispatch via DHL / FedEx

[SUBMIT ONLINE RFQ \(REQUEST FOR QUOTE\) >>](#)

[About Us](#) · [Contact](#) · [All Products](#)