

PLC ProTech Ltd.

Industrial Automation Components

TECHNICAL DOCUMENTATION

SYSTEM INTEGRATION & REPLACEMENT SUPPORT GUIDE

PLC ProTech Ltd. stands at the intersection of complex industrial challenges and high-performance solutions. As a premier global supplier, we specialize in delivering 100% Brand New, factory-sealed components from world-leading brands including ABB, GE, and Honeywell. We maintain an extensive inventory of hard-to-find and discontinued PLC/DCS modules, offering Same-Day Dispatch to over 150 countries. Backed by a 12-month warranty, we empower your operations with technical integrity and peace of mind.

[GET INSTANT QUOTE & INVENTORY STATUS >>](#)

Programmable Controller IC697PWR711/713

GFK-0392G
November 1995

**Power Supply Module, 100W
120/240 VAC, 125 VDC**

NOTE that pages 1 - 4 describe versions A and B (AC input only) of this power supply. Pages 5 - 8 describe versions C and later (120/240 VAC and 125 VDC input).

Features

- Operation from 120 VAC, 240 VAC
- Three output voltages, 100 watts total
 - +5 VDC output up to 18 amps
 - +12 VDC output up to 2 amps
 - 12 VDC output up to 1 amp
- Slide-in rack mount construction
- Electronic short circuit overcurrent protection
- Two rack operation from a single power supply

Functions

The **100 Watt Power Supply Module** is a rack-mounted

unit that plugs directly into a 48-pin backplane-mounted connector in the leftmost slot in the rack. It provides +5 volt, +12 volt and -12 volt power, and logic level sequencing signals to the backplane.

This power supply may be used either in a single rack application, or may also be used to provide power to a second rack if the total load is within the supply rating. Interconnection to the second rack is through a pre-wired cable (see the ordering instructions on the last page of this data sheet).

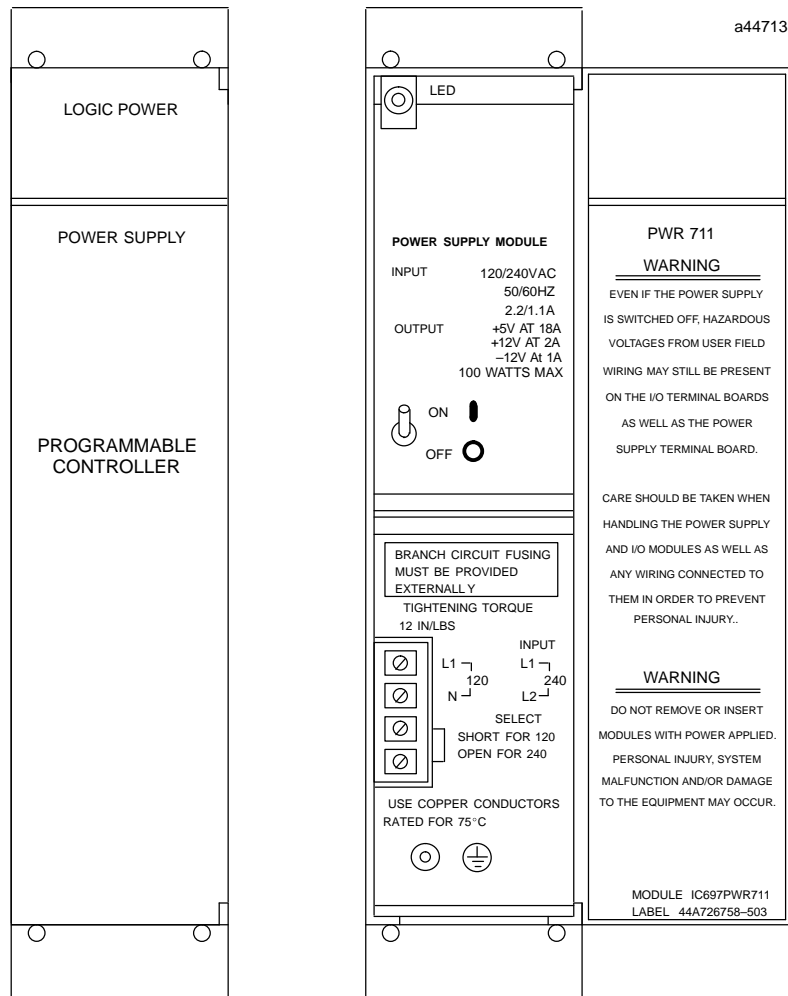

GFK-0392G

The power supply output will ride through a one-cycle total loss of input power at full load. Protection is provided for overcurrent and overvoltage fault conditions.

Operation of the Power Supply

This Power Supply Module can operate from either a 120 volt or 240 volt nominal line (this is jumper selectable, as illustrated on page 3). For these two ranges, the power supply can accept an input voltage range of from 90 to 132 VAC or from 180 to 264 VAC, 47 to 63 Hz.

Overvoltage Protection

The power supply includes an electronic overvoltage protection circuit. This circuit will turn the output off if the 5 volt bus exceeds 6.2 +0.5 V. The power supply must be turned off to be reset. External overvoltage on the output that triggered the overvoltage protection will not cause the power supply fuse to open. However, if an internal fault in the power supply caused the overvoltage condition, the fuse may open. Replace this fuse with a 3AG 3 amp, 250 volt fuse.

Overcurrent Protection

The power supply provides electronic overcurrent protection for each of the 3 outputs. If the maximum current rating is exceeded, the voltage will collapse to a low value.

It will remain in that state until the load is either removed or reduced. A current overload (including a short circuit condition) will not cause the fuse to open.

This power supply does not comply with FCC requirements in non-industrial applications for conducted EMI on AC power lines.

Dual Rack Operation

A single power supply can provide power for two racks under the following conditions:

- Only 5 volt power is required in the second rack, and the total power required by both racks is within the capability of the supply.
- The current drawn by the second rack is less than 5.2 amperes.
- The two racks must be mounted in close proximity as limited by the available 3-foot connecting cable.

The connecting cable used for dual rack operation is listed in Table 1, Ordering Information. This cable carries the +5 volts power bus as well as the power sequencing signals. It uses a 9-pin D-type connector which connects directly to the backplane through an opening in the rack frame. Note that the cable carries power and power sequencing signals only. Inter-rack communication and bus interface modules must be provided separately. See the applicable *Programmable Controller Installation Manual* for application information.

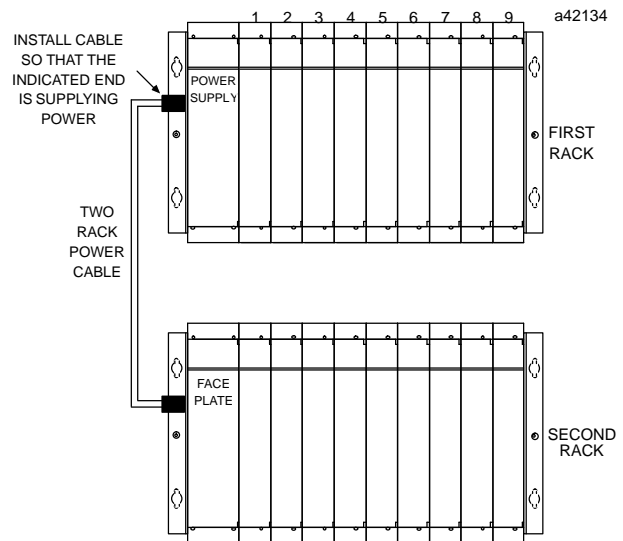

Figure 1. Dual Rack Configuration

Timing Diagram

The timing diagram below shows the relationship of the ac input power to the dc outputs and to the two system signals generated by the power supply: *ACFAIL* and *SYSRESET*. The *5VSTBY* output may be used for user battery backup schemes as shown.

On application of power, the *ACFAIL* signal goes false soon after the 5 volt bus is within specification. The system is held in the Reset state by *SYSRESET* for at least 200 milliseconds after 5 volt power is available (during this time, outputs are forced off).

If AC input power is interrupted, the 5 volt bus will remain within specifications for at least one cycle. The system is then given an additional 5 milliseconds to complete an orderly shutdown before *SYSRESET* stops all processing.

GFK-0392G

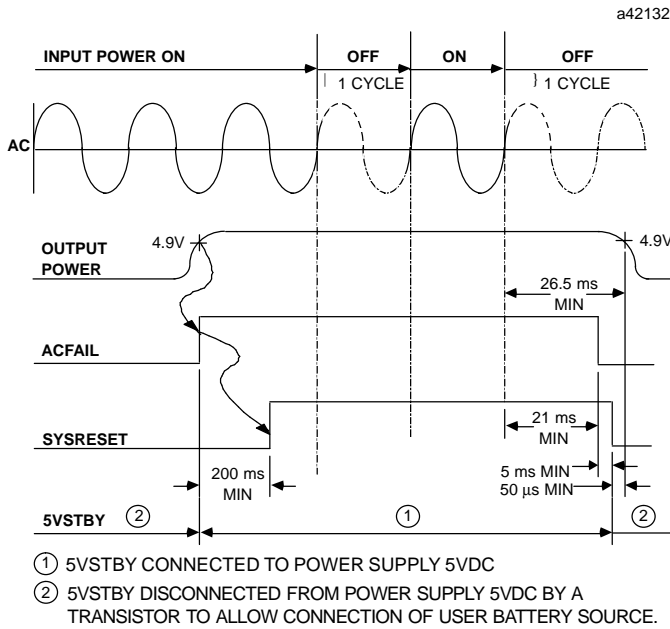

Figure 2. Timing Diagram

Mounting

The Power Supply is a plug-in module which is secured to the rack with four M 2.5 screws (included). Be certain that these screws are tightened both to secure the power supply to the rack, and to assure proper power supply-to-rack grounding.

Power Supply Door

The power supply door can easily be opened by grasping the upper left corner of the door with your right thumb or a fingernail and gently pulling the door towards you. Use care when opening the door since pulling from the bottom can cause the hinge or the door to break.

Input Voltage and Grounding

The power input terminal board provides two points for connecting 120 VAC or 240 VAC power and two additional points which must be shorted together if line voltage is 120 VAC and must be open if line voltage is 240 VAC. Power input connections should be made with copper AWG #16 (1.33 mm²) wire rated for 75°C (167°F).

Each terminal can accept solid or stranded wires, but the wires into any given terminal should be the same type and size.

It is recommended that the GND terminal on the power supply be connected to the GND terminal on the rack and to earth using copper AWG #12 (3.31 mm²) wire rated for 75°C (167°F) and a ring terminal to ensure adequate grounding. Use of a nut and star washer for each wire on the GND lug is recommended.

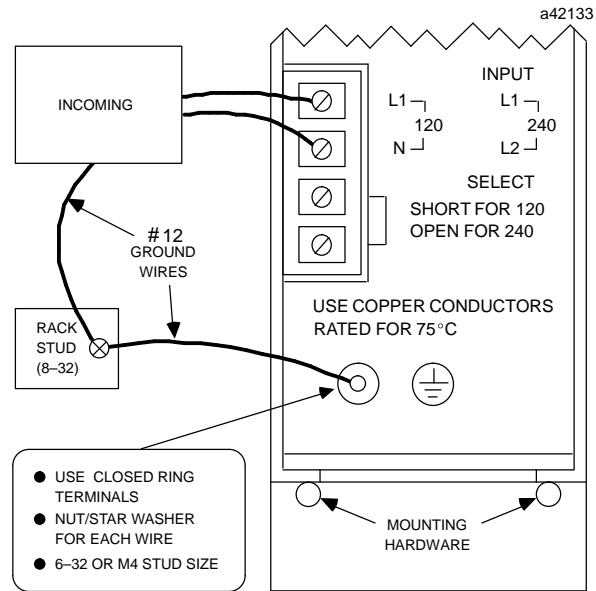

Figure 3. Input Voltage and Ground Connections

Note

Input power interruptions which exceed the power supply holdup time (21 milliseconds minimum) will result in a complete power down/power up cycle of ACFAIL and SYSRESET.

System Noise Immunity

Three easy steps must be taken to properly ground the programmable controller system to reduce the possibility of errors due to electrical noise.

1. Make sure that the power supply mounting screws, especially the bottom two, are properly secured.
2. The GND terminal on the power supply must be connected to the GND terminal on either side of the rack using AWG #12 (3.31 mm²) wire. Use of a ring terminal and starwasher is recommended.
3. The GND terminal on the rack must be connected to a good earth ground.

4 Power Supply Module 120/240 VAC, 125 VDC 100W

GFK-0392G

Table 4. Specifications FOR IC697PWR711/713 (Versions A and B) †

Nominal Rated Voltage:	120 VAC or 240 VAC
Input Voltage Range: AC Input	90-132 VAC or 180-264 VAC, 50 - 60 Hz
Input Power:	160 watts maximum at full load
Input Half Cycle Peak Inrush	55 amps (typical), 77 amps (maximum)
Output Power:	100 watts maximum (total for all 3 outputs)
Output Voltage:	+5 VDC: 4.90 to 5.25 volts (5.07 volts nominal) +12 VDC: 11.75 to 12.6 volts -12 VDC: -12.6 to -11.75 volts
Protective Limits - Overvoltage Limit: Overcurrent Limit:	+5 VDC Output: 5.7 to 6.7 volts +5 VDC output: 26 amp, maximum +12 VDC output: 4 amp, maximum -12 VDC output: 2 amp, maximum
Holdup Time:	21 milliseconds minimum (from loss of AC input)
VME	System designed to support the VME standard C.1

† Refer to data sheet GFK-0867B, or later for product standards and general specifications.

Table 5. Ordering Information

Description	Catalog Number
Power Supply, 120/240Volts AC, 100 Watts	IC697PWR711/713 (Versions A and B)
Power Supply Extension Cable (includes cable and faceplate for vacant power supply slot in second rack).	IC697CBL700

Pages 5 - 8 describe versions C and later (120/240 VAC and 125 VDC input) of this 100W power supply. C and later versions operate from 125 VDC as well as 120/240 VAC power source.

Features

- Operation from 120 VAC, 240 VAC, or 125 VDC
- Three output voltages, 100 watts total
 - +5 VDC output up to 20 amps
 - +12 VDC output up to 2 amps
 - 12 VDC output up to 1 amp
- Slide-in rack mount construction
- Electronic short circuit overcurrent protection
- Two rack operation from a single power supply
- Power Factor correction for AC operation

Functions

The **100 Watt Power Supply Module** is a rack-mounted unit that plugs directly into a 48-pin backplane-mounted connector in the leftmost slot in the rack. It provides +5 volt, +12 volt and -12 volt power, and logic level sequencing signals to the backplane.

This power supply may be used either in a single rack application, or may also be used to provide power to a second rack if the total load is within the supply rating. Interconnection to the second rack is through a pre-wired cable (see the ordering instructions on the last page of this data sheet). dan

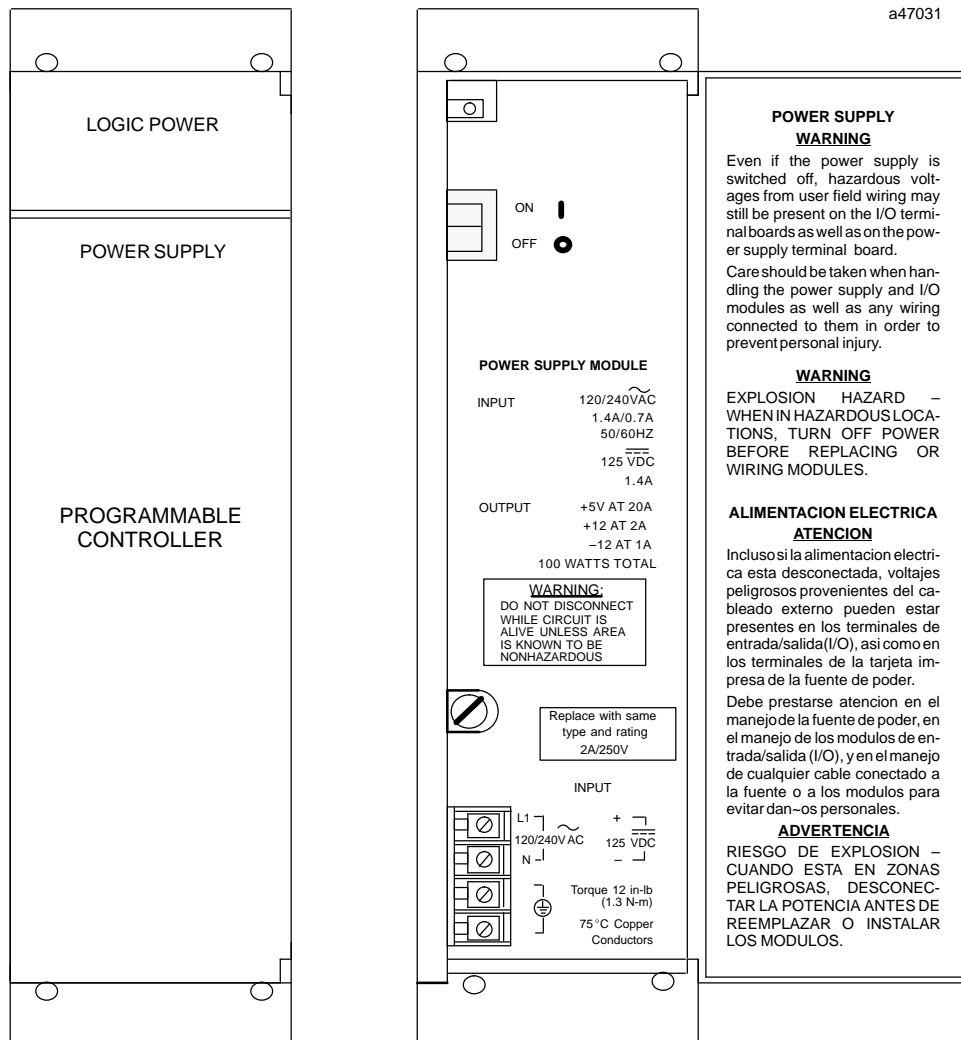

6 Power Supply Module 120/240 VAC, 125 VDC 100W

GFK-0392G

The power supply output will ride through at least one input line cycle with a total loss of input power at full load. Protection is provided for overcurrent and over-voltage fault conditions.

Operation of the Power Supply

This Power Supply module can operate from either 120 VAC or 240 VAC nominal inputs. It will also operate from a nominal 125 VDC source. The specified range of operation is from 90 VAC to 264 VAC, and from 100 VDC to 150 VDC.

For continuous operation (greater than one hour) at low line voltages and high temperatures, some power

derating must be applied. Refer to the following figure to determine the normal operating range for specific applications. Normal operating range is shown by the shaded area of the graph for 60°C (140°F) installations. Operation in the non-shaded region for specific applications must be limited to <1 hour. Reducing the maximum operating temperature to 55°C (131°F) will increase the normal operating range as indicated on the graph.

Active power factor correction circuits in this supply maintain a near unity power factor for AC inputs, which eliminates the need for oversized circuit breakers and wiring. This circuitry also limits the half cycle peak inrush currents to a low value.

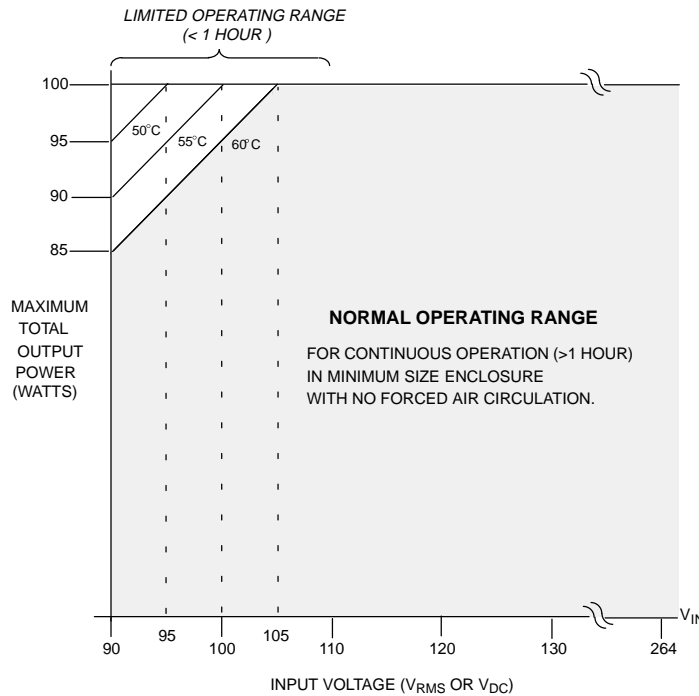

Figure 4. Power Derating for Low Line Voltages

Overvoltage Protection

An electronic shutdown circuit protects against voltages exceeding 6.2 volts. A back-up voltage clamp is provided to protect against sustained overvoltage conditions due to either external influences or internal faults. Overvoltage due to internal faults may cause the fuse to open. For short term overvoltage conditions, normal operation will resume when the cause is removed.

Overcurrent Protection

An electronic current limit is provided on each of the three outputs. An overload on any output will cause the voltage to collapse and may cause the other output voltages to collapse.

Normal operation will resume after removal of the overload. Some component cooling time may be required before normal operation resumes.

Dual Rack Operation

A single power supply can provide power for two racks under the following conditions:

- Only 5 volt power is required in the second rack, and the total power required by both racks is within the capability of the supply.
- The current drawn by the second rack is less than 5.2 amperes.
- The two racks must be mounted in close proximity as limited by the available 3-foot connecting cable.

The connecting cable used for dual rack operation is listed in Table 1, Ordering Information. This cable carries the +5 volts power bus as well as the power sequencing signals. It uses a 9-pin D-type connector which connects directly to the backplane through an opening in the rack frame. Note that the cable carries power and power sequencing signals only. Inter-rack communication and bus interface modules must be provided separately. See the applicable *Programmable Controller Installation Manual*. for application information.

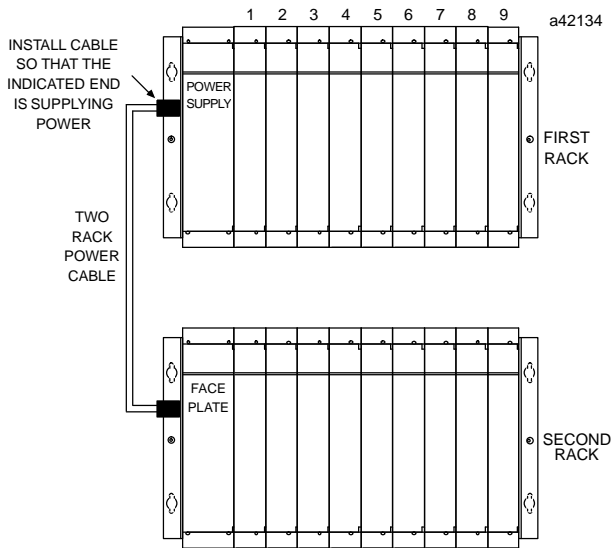

Figure 5. Dual Rack Configuration

Timing Diagram

The timing diagram below shows the relationship of the ac input power to the dc outputs and to the two system signals generated by the power supply: *ACFAIL* and

SYSRESET. The 5VSTBY output may be used for user battery backup schemes as shown.

On application of power, the *ACFAIL* signal goes false soon after the 5 volt bus is within specification. The system is held in the Reset state by *SYSRESET* for at least 200 milliseconds after 5 volt power is available (during this time, outputs are forced off).

If AC input power is interrupted, the 5 volt bus will remain within specifications for at least one cycle. The system is then given an additional 5 milliseconds to complete an orderly shutdown before *SYSRESET* stops all processing.

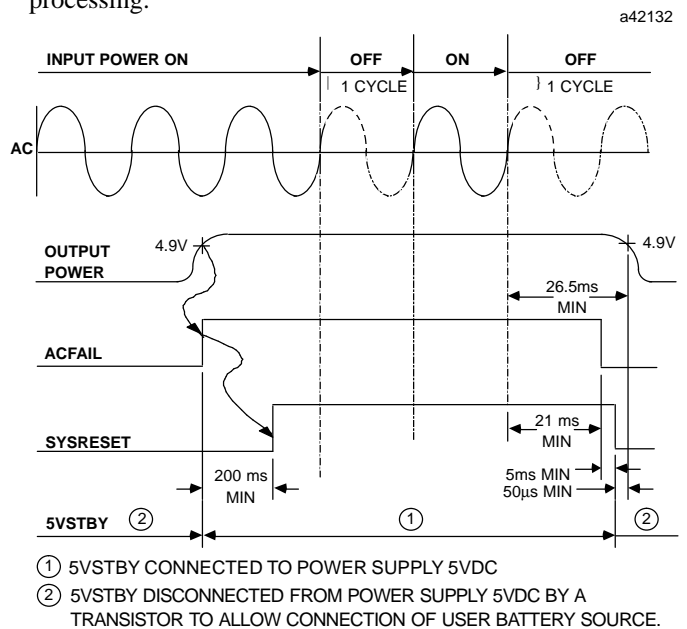

Figure 6. Timing Diagram

Note

Input power interruptions which exceed the power supply holdup time (21 milliseconds minimum) will result in a complete power down/power up cycle of *ACFAIL* and *SYSRESET*.

Mounting

This Power Supply is a plug-in module that is installed in the leftmost slot of any standard IC697 rack or VME Integrator's rack. For additional installation information, refer to GFK-1179, *Installation Guidelines for Conformance to Standards*, shipped with the PLC programming software.

GFK-0392G

Power Supply Door

The power supply door can easily be opened by grasping the upper left corner of the door with your right thumb or a fingernail and gently pulling the door towards you. Use care when opening the door since pulling from the bottom can cause the hinge or the door to break.

Input Voltage and Grounding

The power input terminal board provides two terminals for connecting 120 or 240 VAC, or 125 VDC power. Two additional terminals are provided for safety and frame ground connections. Power input connections should be made with copper AWG #16 (1.33 mm²) wire rated for 75°C (167°F).

Each terminal can accept solid or stranded wires, but the wires into any given terminal should be the same type and size.

It is recommended that one Ground terminal on the power supply be connected to the GND terminal on the rack and to earth using copper AWG #12 (3.31 mm²) wire rated for 75°C (167°F) and a ring terminal to ensure adequate grounding. Use of a nut and star washer for each wire on the GND lug is recommended.

System Noise Immunity

Two easy steps must be taken to properly ground the programmable controller system to reduce the possibility of errors due to electrical noise.

1. One Ground terminal on the power supply must be connected to the GND terminal on either side of the rack using AWG #12 (3.3 mm²) wire. The second Ground terminal should be connected to incoming safety ground.
2. The GND terminal on the rack must be connected to a good earth ground.

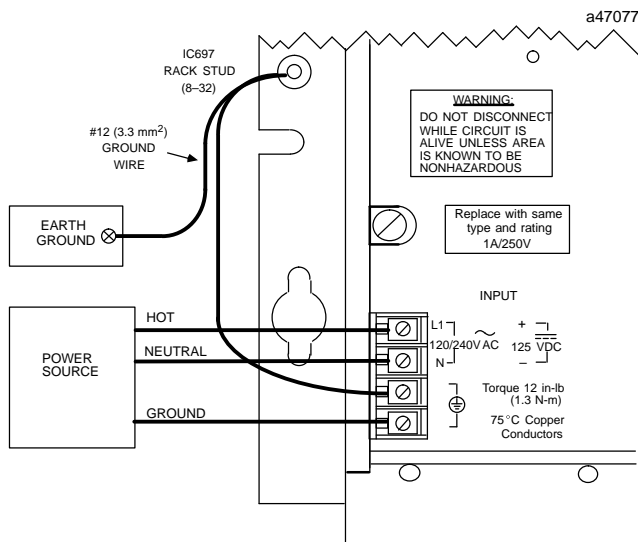

Figure 7. Input Voltage and Ground Connections

Power Supply Module 120/240 VAC, 125 VDC 100W

GFK-0392G

**Table 6. Specifications FOR IC697PWR711/713
(Version C and Later) †**

Nominal Rated Voltage:	120/240 VAC, or 125 VDC
Input Voltage Range: AC Input DC Input	90 to 264 VAC, 47 to 63 Hz 100 to 150 VDC
Input Power: Input Half Cycle Peak Inrush Power Factor	135 watts (typical), 160 watts (maximum) 3 amps (typical) > .93
Output Power: † Output Voltage:	100 watts maximum (total for all 3 outputs) +5 VDC: 4.90 to 5.25 volts (5.07 volts nominal) +12 VDC: 11.75 to 12.6 volts -12 VDC: -12.6 to -11.75 volts
Protective Limits - Overvoltage Limit: Overcurrent Limit:	+5 VDC Output: 5.7 to 6.7 volts +5 VDC output: 21A (typical) +12 VDC output: 3.5A (typical) -12 VDC output: 1.6A (typical)
Holdup Time:	21 milliseconds minimum (from loss of AC input)
Environmental - Operating Temperature:	0° to 60° C (32° to 140° F) operating †† -40° to +85° C (-40° to +185° F) storage

† Refer to data sheet GFK-0867B, or later for product standards and general specifications.

†† Derate for continuous low input voltage, see Figure 4)

Table 7. Ordering Information

Description	Catalog Number
Power Supply, 120/240 Volts AC, or 125 Volts DC 100 Watts	IC697PWR711/713 (Version C or later)
Power Supply Extension Cable (includes cable and faceplate for vacant power supply slot in second rack).	IC697CBL700

CONTACT US & SUPPORT

NEED A QUOTE OR TECHNICAL PARTS REPLACEMENT?

Company Name: [PLC ProTech Ltd.](#)

Online Support: www.plcprotech.com (Click to Visit)

Inquiry Email: sales@plcprotech.com

Direct Hotline: +86 18046317198

Our Service Guarantee:

- 100% Brand New Original & Factory Sealed Components
- 12-Month Quality Warranty on All Industrial Parts
- Worldwide Same-Day Fast Dispatch via DHL / FedEx

[SUBMIT ONLINE RFQ \(REQUEST FOR QUOTE\) >>](#)