

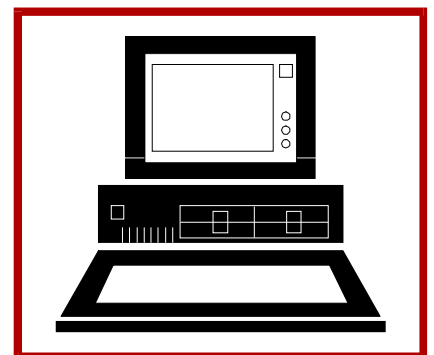

E96-304

Instruction

Analog Slave Input Module (IMASI02)

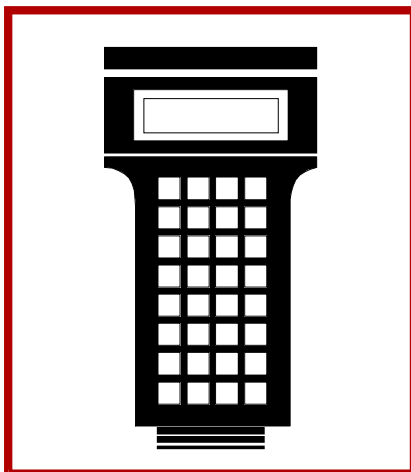
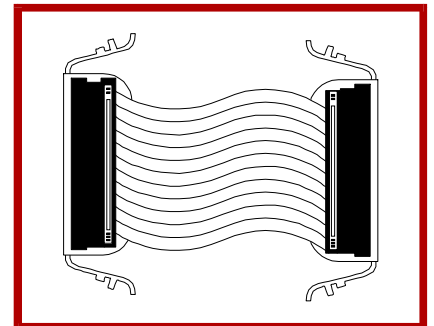
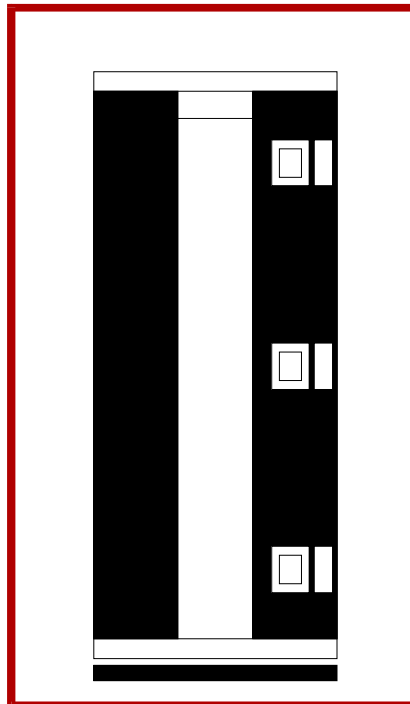
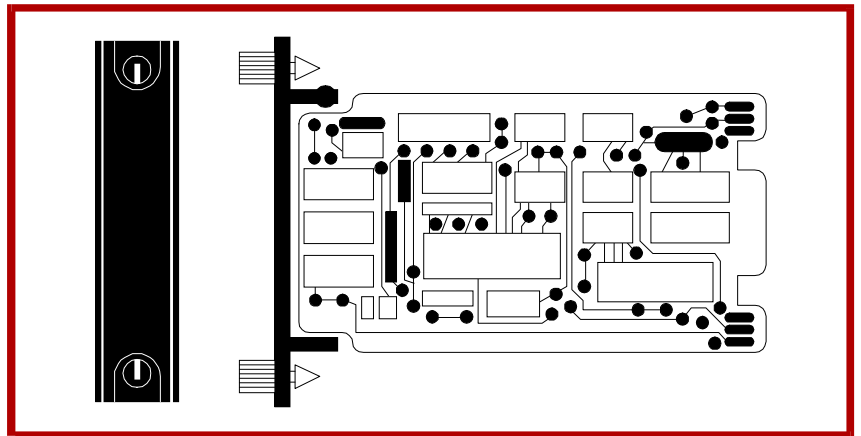
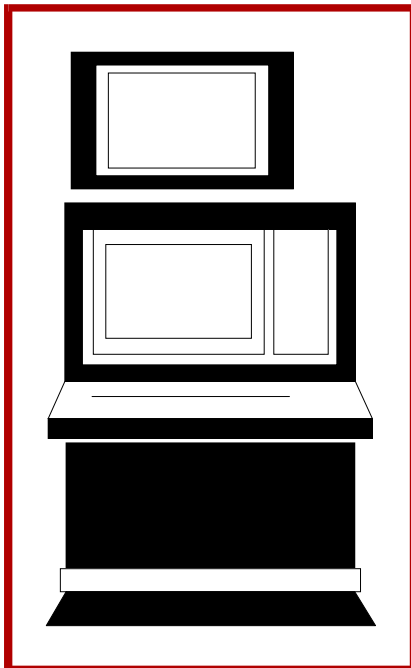

WARNING notices as used in this instruction apply to hazards or unsafe practices that could result in personal injury or death.

CAUTION notices apply to hazards or unsafe practices that could result in property damage.

NOTES highlight procedures and contain information that assists the operator in understanding the information contained in this instruction.

WARNING

INSTRUCTION MANUALS

DO NOT INSTALL, MAINTAIN, OR OPERATE THIS EQUIPMENT WITHOUT READING, UNDERSTANDING, AND FOLLOWING THE PROPER **Elsag Bailey** INSTRUCTIONS AND MANUALS; OTHERWISE, INJURY OR DAMAGE MAY RESULT.

RADIO FREQUENCY INTERFERENCE

MOST ELECTRONIC EQUIPMENT IS INFLUENCED BY RADIO FREQUENCY INTERFERENCE (RFI). CAUTION SHOULD BE EXERCISED WITH REGARD TO THE USE OF PORTABLE COMMUNICATIONS EQUIPMENT IN THE AREA AROUND SUCH EQUIPMENT. PRUDENT PRACTICE DICTATES THAT SIGNS SHOULD BE POSTED IN THE VICINITY OF THE EQUIPMENT CAUTIONING AGAINST THE USE OF PORTABLE COMMUNICATIONS EQUIPMENT.

POSSIBLE PROCESS UPSETS

MAINTENANCE MUST BE PERFORMED ONLY BY QUALIFIED PERSONNEL AND ONLY AFTER SECURING EQUIPMENT CONTROLLED BY THIS PRODUCT. ADJUSTING OR REMOVING THIS PRODUCT WHILE IT IS IN THE SYSTEM MAY UPSET THE PROCESS BEING CONTROLLED. SOME PROCESS UPSETS MAY CAUSE INJURY OR DAMAGE.

AVERTISSEMENT

MANUELS D'OPÉRATION

NE PAS METTRE EN PLACE, RÉPARER OU FAIRE FONCTIONNER L'ÉQUIPEMENT SANS AVOIR LU, COMPRIS ET SUIVI LES INSTRUCTIONS RÉGLEMENTAIRES DE **Elsag Bailey**. TOUTE NÉGLIGENCE À CET ÉGARD POURRAIT ÊTRE UNE CAUSE D'ACCIDENT OU DE DÉFAILLANCE DU MATÉRIEL.

PERTURBATIONS PAR FRÉQUENCE RADIO

LA PLUPART DES ÉQUIPEMENTS ÉLECTRONIQUES SONT SENSIBLES AUX PERTURBATIONS PAR FRÉQUENCE RADIO. DES PRÉCAUTIONS DEVRONT ÊTRE PRISES LORS DE L'UTILISATION DU MATÉRIEL DE COMMUNICATION PORTATIF. LA PRUDENCE EXIGE QUE LES PRÉCAUTIONS À PRENDRE DANS CE CAS SOIENT SIGNALÉES AUX ENDROITS VOULUS DANS VOTRE USINE.

PERTURBATIONS DU PROCÉDÉ

L'ENTRETIEN DOIT ÊTRE ASSURÉ PAR UNE PERSONNE QUALIFIÉE EN CONSIDÉRANT L'ASPECT SÉCURITAIRE DES ÉQUIPEMENTS CONTRÔLÉS PAR CE PRODUIT. L'AJUSTEMENT ET/OU L'EXTRACTION DE CE PRODUIT PEUT OCCASIONNER DES À-COUPS AU PROCÉDÉ CONTRÔLE LORSQU'IL EST INSÉRÉ DANS UNE SYSTÈME ACTIF. CES À-COUPS PEUVENT ÉGALEMENT OCCASIONNER DES BLESSURES OU DES DOMMAGES MATÉRIELS.

NOTICE

The information contained in this document is subject to change without notice.

Elsag Bailey, its affiliates, employees, and agents, and the authors and contributors to this publication specifically disclaim all liabilities and warranties, express and implied (including warranties of merchantability and fitness for a particular purpose), for the accuracy, currency, completeness, and/or reliability of the information contained herein and/or for the fitness for any particular use and/or for the performance of any material and/or equipment selected in whole or part with the user of/or in reliance upon information contained herein. Selection of materials and/or equipment is at the sole risk of the user of this publication.

This document contains proprietary information of Elsag Bailey, Elsag Bailey Process Automation, and is issued in strict confidence. Its use, or reproduction for use, for the reverse engineering, development or manufacture of hardware or software described herein is prohibited. No part of this document may be photocopied or reproduced without the prior written consent of Elsag Bailey.

Preface

The Analog Slave Input module (IMASI02) is an interface that supplies fifteen separate process field signals into the Infi 90 Process Management System. These analog inputs are used by the Multi-Function Processor Module (MFP) to monitor and control a process. The slave can also send operating commands it receives from the MFP or the Smart Transmitter Terminal (STT) to Bailey Controls smart transmitters.

This instruction explains the slave module features, specifications and operations. It details the procedures you must follow to set up and install an ASI module, and explains status indicators that help in system test and diagnosis.

The system engineer or technician using the ASI should read and understand this instruction before installing and operating the slave module. In addition, a complete understanding of the Infi 90 system is beneficial to the user.

List of Effective Pages

Total number of pages in this instruction is 40, consisting of the following:

Page No.	Change Date
Preface	Original
List of Effective Pages	Original
iii through vii	Original
1-1 through 1-6	Original
2-1 through 2-6	Original
3-1 through 3-5	Original
4-1	Original
5-1 through 5-2	Original
6-1 through 6-4	Original
7-1	Original
8-1	Original
9-1	Original
A-1 through A-3	Original
B-1 through B-3	Original

When an update is received, insert the latest changed pages and dispose of the superseded pages.

NOTE: On an update page, the changed text or table is indicated by a vertical bar in the outer margin of the page adjacent to the changed area. A changed figure is indicated by a vertical bar in the outer margin next to the figure caption. The date the update was prepared will appear beside the page number.



Safety Summary

**GENERAL
WARNINGS****Equipment Environment**

All components, whether in transportation, operation or storage, must be in a noncorrosive environment.

Electrical Shock Hazard During Maintenance

Disconnect power or take precautions to ensure that contact with energized parts is avoided when servicing.

Special Handling

This module uses Electrostatic Sensitive Devices (ESD).

**SPECIFIC
WARNINGS**

Disconnect power before installing dipshunts for slave modules on the MMU backplane (slave expander bus). Failure to do so could result in severe or fatal shock. (p. 3-4)

Sommaire de Sécurité

**AVERTISSEMENTS
D'ORDRE
GÉNÉRAL**

Environnement de l'équipement

Ne pas soumettre les composants à une atmosphère corrosive lors du transport, de l'entreposage ou l'utilisation.

Possibilité de chocs électriques durant l'entretien

Débrancher l'alimentation ou prendre les précautions pour éviter tout contact avec des composants sous tension durant l'entretien.

Precautions de Manutention

Ce module contient des composants sensibles aux decharges electro-statiques.

**AVERTISSEMENTS
D'ORDRE
SPÉCIFIQUE**

Couper l'alimentation avant d'installer les dipshunts sur la plaque arriere du chassis de montage de modules (MMU). Toute negligence a cet egard constitue un risque de choc pouvant entrainer des blessures graves, voire moretiles. (p. 3-4)

Table of Contents

	<i>Page</i>
SECTION 1 - INTRODUCTION.....	1-1
OVERVIEW	1-1
INTENDED USER.....	1-2
MODULE DESCRIPTION	1-2
FEATURES.....	1-2
INSTRUCTION CONTENT	1-3
HOW TO USE THIS MANUAL	1-4
REFERENCE DOCUMENTS.....	1-4
NOMENCLATURE	1-4
SPECIFICATIONS.....	1-5
GLOSSARY OF TERMS AND ABBREVIATIONS	1-6
SECTION 2 - DESCRIPTION AND OPERATION.....	2-1
INTRODUCTION.....	2-1
FUNCTIONAL OPERATION	2-1
INPUTS	2-1
Input Circuit Description	2-2
Input Circuit Connections	2-2
PROCESSOR AND CONTROL LOGIC	2-2
A/D CONVERSION.....	2-3
SMART TRANSMITTER COMMUNICATION	2-3
MFP Communication	2-4
STT Terminal Communication.....	2-4
Smart Transmitter Communication	2-4
Command Buffering During Transmitter Communication Failure	2-4
Data Byte.....	2-5
Status Byte.....	2-5
Security Byte	2-5
Communication Lockout Byte	2-5
LOGIC POWER.....	2-6
SLAVE EXPANDER BUS.....	2-6
UNIVERSAL SLAVE EXPANDER BUS INTERFACE.....	2-6
SECTION 3 - INSTALLATION.....	3-1
INTRODUCTION.....	3-1
SPECIAL HANDLING	3-1
UNPACKING AND INSPECTION	3-1
SETUP/INSTALLATION	3-2
Slave Address Selection Switch (S1)	3-2
Termination Unit/Module Configuration	3-3
Physical Installation.....	3-3
WIRING CONNECTIONS AND CABLING	3-4
Wiring.....	3-4
Cable Connections	3-4
FUSING.....	3-5
PRE-OPERATING ADJUSTMENTS	3-5

Table of Contents (continued)

	<i>Page</i>
SECTION 4 - CALIBRATION.....	4-1
INTRODUCTION	4-1
ADJUSTING R22.....	4-1
SECTION 5 - OPERATING PROCEDURES.....	5-1
INTRODUCTION	5-1
START-UP.....	5-1
OPERATION.....	5-1
SECTION 6 - TROUBLESHOOTING.....	6-1
INTRODUCTION	6-1
ERROR MESSAGES AND CORRECTIVE ACTION	6-1
Status Reports	6-1
Master Module Errors.....	6-2
MODULE PIN CONNECTIONS.....	6-3
SECTION 7 - MAINTENANCE.....	7-1
INTRODUCTION	7-1
MAINTENANCE SCHEDULE	7-1
SECTION 8 - REPAIR/REPLACEMENT PROCEDURES.....	8-1
INTRODUCTION	8-1
MODULE REPAIR/REPLACEMENT.....	8-1
SECTION 9 - SUPPORT SERVICES.....	9-1
INTRODUCTION	9-1
REPLACEMENT PARTS AND ORDERING INFORMATION	9-1
TRAINING.....	9-1
TECHNICAL DOCUMENTATION.....	9-1
APPENDIX A - TERMINATION UNIT (NTAI05) CONFIGURATION.....	A-1
INTRODUCTION	A-1
CONFIGURING INPUTS	A-1
APPENDIX B - TERMINATION MODULE (NIAI04) CONFIGURATION.....	B-1
INTRODUCTION	B-1
CONFIGURING INPUTS	B-1

List of Figures

<i>No.</i>	<i>Title</i>	<i>Page</i>
1-1.	Infi 90 Communication Levels	1-1
2-1.	IMASIO2 Functional Block Diagram	2-1
2-2.	IMASIO2 Analog Input Circuit	2-2
2-3.	A/D Converter	2-3
3-1.	Address Select Switch (S1)	3-2
3-2.	IMASIO2 Cable Connections and Termination.....	3-5
5-1.	IMASIO2 Adapter Jack Location	5-2
A-1.	Input Circuit for NTAIO5	A-1
A-2.	Dipshunts for NTAIO5	A-2
A-3.	Terminal Assignments for NTAIO5	A-3
A-4.	Cable Connections for NTAIO5.....	A-3
B-1.	Input Circuit for NIAIO4	B-1
B-2.	Dipswitch Settings for NIAIO4	B-2
B-3.	Terminal Assignments for NIAIO4	B-3
B-4.	Cable Connections for NIAIO4	B-3

List of Tables

<i>No.</i>	<i>Title</i>	<i>Page</i>
3-1.	Address Switch Settings (S1)	3-3
6-1.	ASI Error Code.....	6-2
6-2.	Smart Transmitter Error Codes	6-2
6-3.	P1 Power Pin Connections	6-3
6-4.	P2 Expander Bus Connections	6-4
6-5.	P3 Input Signal Pin Connections	6-4
7-1.	Maintenance Schedule	7-1

SECTION 1 - INTRODUCTION

OVERVIEW

The Analog Slave Input Module (IMASIO2) inputs 15 channels of analog signals to the Multi-Function Processor (IMMFP01/02) or Network 90 Multi-Function Controllers. It is a dedicated slave module that connects field equipment and Bailey smart transmitters to the master modules in the Infi 90/Network 90 System.

The slave also provides a signal path from an Infi 90 operator interface such as Operator Interface Station (OIS), or Configuration and Tuning Terminal (CTT) to the Bailey Controls smart transmitters. The OIS or CTT connects to the Bailey Controls smart transmitters through the MFP and the ASI. See Figure 1-1 for Infi 90 communication levels.

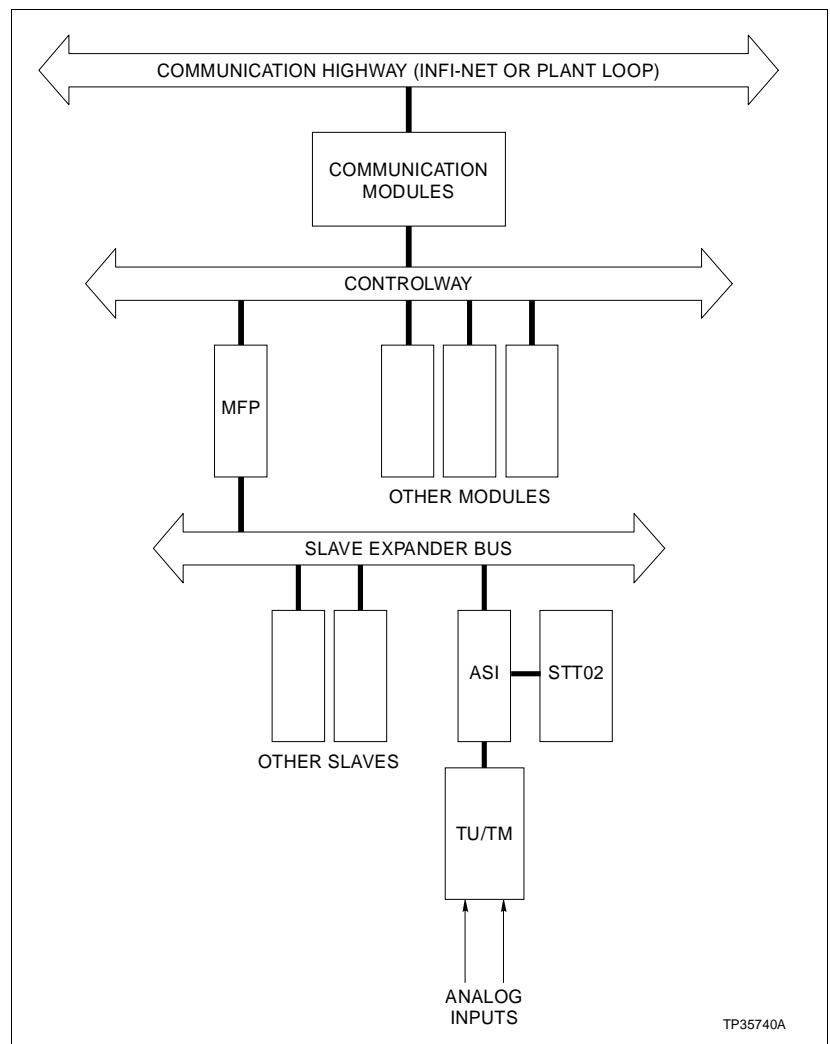

Figure 1-1. Infi 90 Communication Levels

This manual explains the purpose, operation, maintenance, handling precautions and installation procedures of the Analog Slave Input (ASI) module.

INTENDED USER

System engineers and technicians should read this manual before installing and operating the ASI module. Put the module into operation only after reading and understanding this instruction. Refer to the Table of Contents to find the information you need. Refer to the **HOW TO USE THIS MANUAL** entry in this section to help you get started.

MODULE DESCRIPTION

The ASI is a single printed circuit board that uses one slot in a Module Mounting Unit (MMU). Two captive screws on the module faceplate secure it to the MMU. The slave module has three card edge connectors for external signals and power: P1, P2 and P3. P1 connects to common and supply voltages. P2 connects the module to the master module through the slave expander bus.

Connector P3 carries the inputs from the input cable plugged into the Termination Unit (TU) or Termination Module (TM). The terminal blocks for field wiring are on the TU/TM. Refer to Tables 6-3 through 6-5.

The connector on the front of the module is for the STT01 terminal. The STT02 terminal can connect to this plug if you change the cable. The optional cable to connect the STT02 to the ASI can be ordered from your local Bailey Sales Office (order kit number 258445_1). The STT terminal enters commands through the ASI to the smart transmitters in the process system.

The single dipswitch on the ASI module sets the address for the module. Refer to **Section 3** for the steps to set the module address. Be sure to double check the switch setting before putting the module into the MMU.

FEATURES

The design of the ASI module, as with all Infi 90 modules, allows for flexibility in creating a process management system. Refer to **NOMENCLATURE** in this section to see the list of devices that can be used with the slave module in an Infi 90 system.

The ASI uses baseband communication designed for Bailey old-style smart BC/EQ/pH transmitters. Baseband allows digital signals to flow with the analog data. You always have access to the real time process status.

The ASI stores process data, control commands and transmitter setup data in memory. It can restore communication with a transmitter if a failure occurs. After it restores communication, the ASI checks the transmitter setup before the MFP resumes process control.

You can send commands to change transmitter operating parameters and calibration, and to view process data. Connect a hand-held Smart Transmitter Terminal (STT) to the adapter jack on the ASI front plate to enter transmitter commands by hand.

The ASI module can be removed or installed without turning off power to the system.

INSTRUCTION CONTENT

This manual has eleven sections.

Introduction	Is an overview of the ASI module: features, description and specifications.
Description and Operation	Explains the module operation and input circuits.
Installation	Describes cautions to observe when handling ASI modules. It shows the steps to follow to install and connect the module before you apply power. This section also presents switch and jumper settings.
Calibration	Presents steps to verify if the ASI module is calibrated.
Operating Procedures	Explains the front panel connector and start-up of the slave module.
Troubleshooting	Describes how to monitor the transmitter errors from the status reports. It explains how to check for MFP and OIS error and corrective actions to take.
Maintenance	Has a schedule for taking care of the slave module. This schedule can be used for all the modules in the MMU.
Repair/Replacement Procedures	Contains the cautions and steps for taking out and replacing modules from the MMU.
Support Services	Provides a list of information to present when you order parts from your local Bailey Sales Office. It explains other areas of support that Bailey Controls provides.
Appendix A and Appendix B	Contain data to connect the termination unit/module to the ASI. Appendix A shows the dipswitch settings, terminal wiring for the termination unit and the cabling needed for the ASI. Appendix B shows the jumper settings, terminal wiring for the termination module and the cabling needed for the ASI.

HOW TO USE THIS MANUAL

Read this manual before handling the ASI module. Refer to the sections in this list as needed for more information.

1. Read **Section 1** before you connect the IMASI02.
2. Read and do the steps in **Section 3**.
3. Read and do the steps in **Section 4**.
4. Refer to **Section 6** for what to do if a problem occurs.
5. Refer to **Section 7** for the scheduled steps needed to maintain the ASI.
6. Refer to **Section 8** for how to replace a module.
7. Use **Section 9** for how to order parts. This section also tells you some services Bailey offers.

REFERENCE DOCUMENTS

Document Number	Description
I-E96-201	Multi-Function Processor (IMMFP01)
I-E96-202	Multi-Function Processor (IMMFP02)
I-E93-911	Termination Unit Manual
I-E96-110	Operator Interface Station
I-E93-916	Engineering Work Station
I-E92-501-2	Configuration and Tuning Terminal
I-E21-28	Smart Transmitter Terminal (STT02)
I-E93-900-20	Function Code Application Manual

NOMENCLATURE

The following modules and equipment can be used with an ASI module:

Hardware	Nomenclature
IMMFP01/02	Multi-Function Processor Module
NIAI04	Termination Module, Analog Inputs
NTAI05	Termination Unit, Analog Inputs
NKTM01, NKTU02	Cable, Termination Module
NKTU01	Cable, Termination Unit
STT02	Smart Transmitter Terminal
BC	Bailey Pressure Transmitters
EQ	Bailey Temperature Transmitters
pH	Bailey pH Transmitters

SPECIFICATIONS

Logic Power	5 VDC \pm 5% at 85 mA typical + 15 VDC \pm 5% at 25 mA typical - 15 VDC \pm 5% at 20 mA typical
Power Dissipation	1.1 W typical
Operating	
Analog Inputs	15 Independently configured channels: Analog Input Ranges; 4-20 mA, 1-5 VDC, 0-1 VDC, 0-5 VDC, 0-10 VDC, -10 VDC to +10 VDC
Analog Updates	A/D Conversions 10 times per second
A/D Resolution	14 Bits with polarity
Analog Accuracy	0.1% for 4-20 mA 1-5 VDC, 0-5 VDC 0-10 VDC and \pm 10 VDC 0.25% for 0-1 VDC
Common Mode Voltage	-12 VDC minimum +15 VDC maximum \pm 12 VDC for \pm 1 VDC input span \pm 10 VDC for \pm 5 VDC input span \pm 5 VDC for \pm 10 VDC input span
Common Mode Rejection	90 dB minimum at 60 Hz
Normal Mode Rejection	70 dB minimum at 60 Hz
Input Impedance	>1 Megohm
Environmental	
Electromagnetic/ Radio Frequency Interference	No values available at this time. Keep cabinet doors closed. Do not use communication equipment closer than 2 meters from the cabinet.
Ambient Temperature	0° to 70° C (0° to 158° F)
Relative Humidity	5% to 95% up to 55° C (131° F) (non-condensing) 5% to 45% at 70° C (158° F) (non-condensing)
Atmospheric Pressure	Sea level to 3 km (1.86 miles)
Air Quality	Noncorrosive
Mounting	Occupies a single slot in a standard Infi 90 Module Mounting Unit (MMU).
Certification	CSA certified for use as process control equipment in an ordinary (nonhazardous) location.

SPECIFICATIONS SUBJECT TO CHANGE WITHOUT NOTICE

GLOSSARY OF TERMS AND ABBREVIATIONS

Term	Definition
A/D Conversion	Analog-to-digital conversion.
Configuration	A control strategy with function blocks.
Controlway	A redundant peer-to-peer communication path for point data transfer between intelligent modules within a process control unit.
Digital	A discrete input signal having only ON and OFF states.
Dipshunt	Dual in-line package with shorting bars.
Dipswitch	A dual in-line package that contains single pole switches.
EWS	Engineering Work Station; an integrated hardware and software personal computer system for configuring and monitoring Infi 90 modules and systems.
Function Code	An algorithm that defines specific functions. These functions link together to form the control strategy.
LED	Light Emitting Diode; the module front panel indicator that shows status and error messages.
LSB	Least Significant Bit; the bit of a binary number that carries the least numerical weight.
Master Module	One of a series of controller modules designed to direct field processes through a slave module. The multi-function processor is an example.
MFP	Multi-Function Processor Module; a multiple-loop controller with data acquisition and information processing capabilities.
MMU	Module Mounting Unit; a card cage that provides electrical and communication support for Infi 90 modules.
MSB	Most Significant Bit; the bit of a binary number that carries the most numerical weight.
OIS	Operator Interface Station; integrated operator console with data acquisition and reporting capabilities. It provides a window into the process for flexible control and monitoring.
PCU	Process Control Unit; rack type industrial cabinet that contains master, slave and communication modules, and their communication paths.
Pressure Manifold	(Automatic remote) Manifold through which pressure transmitters receive differential pressure inputs. Receives signals from smart transmitters to set manifold to operate position, or to provide a zero differential pressure input for transmitter zero output calibration.
Slave Expander Bus	A parallel address/data bus between the master module and the slave.
Smart Transmitter	A field measuring device that can handle digital communication. It allows configuring of operating parameters, on-line parameter changes, and remote troubleshooting.
TM	Termination Module: Provides input/output connection between plant equipment and the Infi 90 process modules. The termination module slides into a slot in the termination mounting unit.
TU	Termination Unit: Provides input/output connection between plant equipment and the Infi 90 process modules. The termination unit is a flat circuit board for panel mounting.

SECTION 2 - DESCRIPTION AND OPERATION

INTRODUCTION

This section explains the inputs, control logic, communication and connections for the Analog Slave Input (ASI) module. The analog slave performs three major tasks.

- Interfacing analog inputs to the Multi-Function Processor (MFP).
- Interfacing communication between the Infi 90 control system and Bailey Controls smart transmitters.
- Providing an interface for hand-held terminal communications with Bailey Controls smart transmitters.

FUNCTIONAL OPERATION

Figure 2-1 shows a block diagram of the IMASIO2 input module. Refer to this figure when you read the module description. Note that the digital smart transmitter command signal rides on the analog input signal.

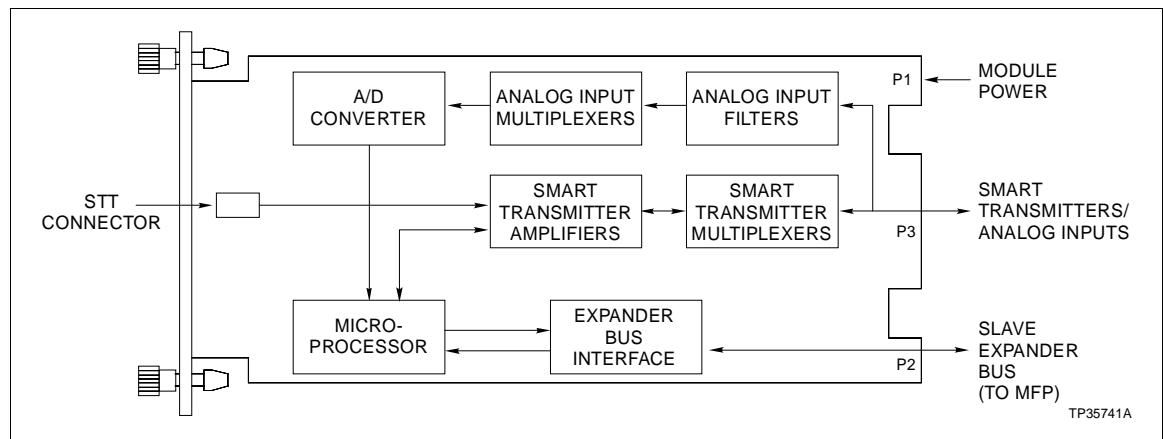

Figure 2-1. IMASIO2 Functional Block Diagram

INPUTS

The analog input signal enters the P3 card edge connector on the ASI module. The analog input filters separate the analog signal from the digital 100 millivolt signal. The analog input multiplexers select the sequence to convert the analog input signals to digital signals. The signals are changed from up to ± 10 VDC to logic levels in the A/D converter.

The ASI interfaces 15 channels of analog inputs from field equipment and smart transmitters to the MFP. Inputs from the field connect to Termination Module NIAI04 or Termination Unit NTAI05. The termination devices connect through cables to the ASI. The ASI accepts analog inputs from any device with current or voltage outputs. Input voltages may be: 4 to 20 mA, 0 to 1 VDC, 0 to 5 VDC, 0 to 10 VDC, 1 to 5 VDC, or -10 VDC to +10 VDC.

The ASI constantly does A/D conversions on each input channel at 10 times per second. The ASI memory stores all converted digital values until it sends them to the MFP.

Upon system start-up, the MFP does not accept inputs from a smart transmitter channel until the transmitter receives its complete configuration from the ASI.

Input Circuit Description

Input signals go through two low band pass filters to the A/D converter. Figure 2-2 shows a typical analog input circuit.

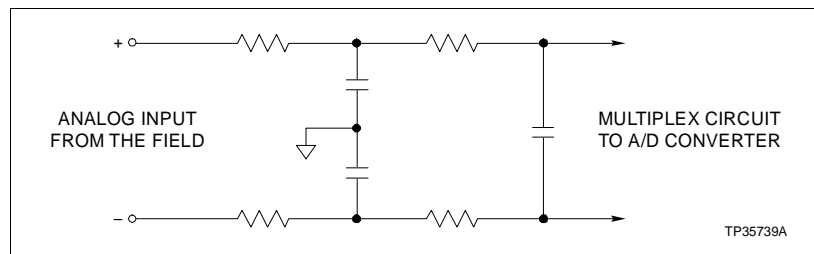

Figure 2-2. IMASIO2 Analog Input Circuit

Input Circuit Connections

Analog input signals from a termination unit or module connect to the P3, 30-pin, card edge connector through a cable.

PROCESSOR AND CONTROL LOGIC

The on board microprocessor on the ASI coordinates module functions. The microprocessor has four main functions:

- Storing the digital data in RAM memory.
- Coordinating A/D conversion.
- Preparing the digital commands to send to the smart transmitters.
- Reading and sending data to the MFP.

The microprocessor sends command signals to the smart transmitters through the smart transmitter amplifier and smart transmitter multiplexers. The smart transmitter amplifier converts the logic level commands to 100 millivolt commands. The smart transmitter multiplexers select the channel (and the analog signal) that the command rides on.

The MFP communicates with the ASI over the slave expander bus. The slave expander bus interface circuit interfaces the microprocessor to the slave expander bus. Function code (FC) 132 or 133 allows the master module to read point (input) data or status data from the ASI automatically. This data is output by the ASI buffer circuits in the control logic to the slave expander bus interface. The slave address in FC 132 or FC 133 must be the same as the address set on the slave address dipswitch S1.

A/D CONVERSION

A dual slope analog to digital converter does the A/D conversion. It has 14 bit resolution and polarity detection. The A/D chip contains the logic to control the converter. The ASI converts each channel about every 100 milliseconds. The ASI stores the converted data in memory. When the MFP requests the data for the channel, the ASI sends the converted data. The ASI also sends two transmitter status bytes for each channel, see Figure 2-3.

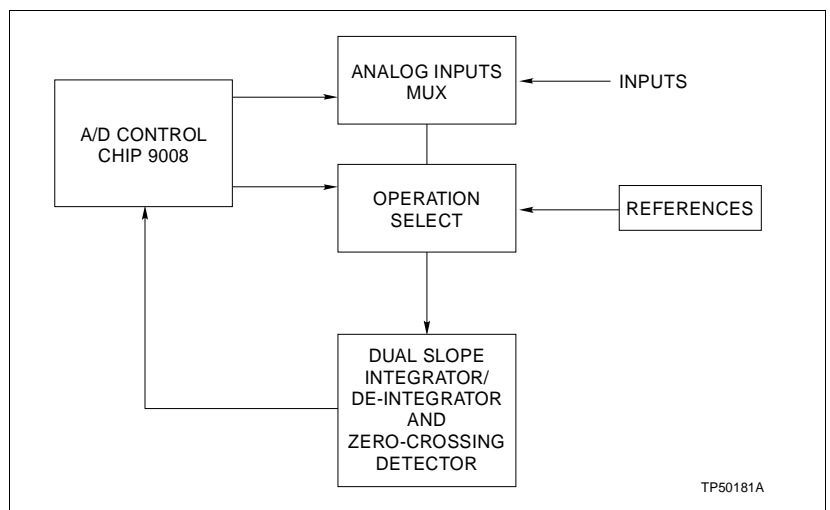

Figure 2-3. A/D Converter

SMART TRANSMITTER COMMUNICATION

The digital interface through the ASI and the MFP provides a communication path between an Infi 90 operator interface and the Bailey Controls smart transmitters (Figure 1-1). The operator can send commands from an operator interface to change

transmitter parameters such as range, or to calibrate transmitter output. Transmitters also send process and status data through the ASI for the Infi 90 system to monitor. Access this status data from the status reports. Refer to [Section 6](#) for more detail on using the status reports.

MFP Communication

The MFP communicates with the ASI over the slave expander bus in parallel digital format. The ASI slave bus interface converts this parallel format to serial digital format and sends it to the transmitters over the current loop.

STT Terminal Communication

An adapter jack on the front plate of the ASI allows the connection of a portable Smart Transmitter Terminal (STT). The STT monitors outputs of a field device connected to the ASI. It handles these transmitter commands: select the channel, change the ID tag, report the input or output, report the status, get the configuration data.

Smart Transmitter Communication

System start-up downloads the smart transmitter configurations and operating ranges from the MFP through the ASI. The MFP sends commands to the transmitters to change parameters. Command functions include: calculating range, doing output calibration, and operating an automatic remote manifold.

Command Buffering During Transmitter Communication Failure

If any command fails to get to a transmitter, the ASI halts communication with that transmitter. The ASI already has the transmitter setup data stored in memory. The ASI now stores the set of transmitter commands an operator enters during the communication failure. The ASI can store two commands, one from each column in the list.

AUTOZERO	MANIFOLD RUN
OUTPUT ZERO	MANIFOLD ZERO
OUTPUT SPAN	
FIX OUTPUT	
CANCEL	

The ASI tries to restart communication with a failed smart transmitter once each minute. When communication over a failed channel resumes, the ASI downloads the setup data and stored commands to that transmitter.

The operator can enter one command from each column through the MFP during a failure. The ASI stores only the last command entered of each set. The transmitter receives this last command when the parameters download from the ASI.

Data Byte

The point data is two 8-bit bytes, each bit of data represents one input. The bit value reflects the state of that input, either open (logic 1) or closed (logic 0).

Status Byte

The status byte makes sure the slave expander bus data and the master module setup data are correct. The ASI sends a status byte to ensure correct data transfer. The status byte compares the sum of the bytes sent to the sum of the bytes received. The master module reads the status byte and compares it to an expected value. If a mismatch occurs, it flags the error and marks the point as bad quality.

Security Byte

When a smart transmitter is operating with the ASI in a control system, transmitter operating parameters should not be changed except through the ASI. To prevent changes, the ASI sends a security byte at the beginning of each communication. The security byte triggers the smart transmitters to take commands only from the ASI. The security byte locks out commands, such as reranging, from any other interface device. These devices (smart transmitter terminals) connect to the transmitter current loop.

Communication Lockout Byte

In normal operation, the ASI sends the lockout byte once each minute to the smart transmitters when the ASI checks transmitter status. If the ASI does not send a byte within a two minute period, the transmitter unlocks itself, and accepts commands from other sources on the current loop. You can unlock transmitters to allow communication from other sources. To do this, set specification 1 in Function Code 133, smart transmitter definition. This lockout feature prevents unwanted transmitter configuration changes. To enter changes, connect a STT terminal to the plug in the front of the ASI module. Changes also can be entered through another interface device connected to the transmitter current loop while the system is operating.

LOGIC POWER

Power from the MMU backplane (+5, ± 15 VDC) drives the ASI circuits. It connects through the top 12-pin card edge connector (P1) at the back of the ASI.

SLAVE EXPANDER BUS

The Infi 90 slave expander bus is a high speed synchronous parallel bus. It provides a path between master modules and slave modules. The master module sends control functions to the ASI, and the ASI module provides input to the master module. Both the P2 card edge connector of the ASI and master module connect to the bus.

The slave expander bus is twelve parallel signal lines located on the module mounting unit (MMU) backplane. A 12-position dipshunt placed in a socket on the MMU backplane connects the bus between the master and slave modules. Cable assemblies can extend the bus to six MMUs.

A master module and its slaves form a subsystem within a Process Control Unit (PCU). The slave expander bus between master/slave subsystems must be separated. Leaving a dipshunt socket empty or not connecting the MMUs with cables separates them.

UNIVERSAL SLAVE EXPANDER BUS INTERFACE

The ASI uses a semi-custom gate array for the slave expander bus interface. An integrated circuit (IC) holds all the control logic and communication protocol. This IC provides the following functions:

- Address comparison and detection.
- Function code latching and decoding.
- Read strobe generation.
- Data line filtering of bus signals.
- On-board bus drivers.

SECTION 3 - INSTALLATION

INTRODUCTION

This section explains what to do before you put the Analog Slave Input Module (IMASIO2) into operation. **DO NOT PROCEED** with operation until you read, understand and do the steps in the order in which they appear.

NOTE: Refer to Product Instruction I-E93-911 for termination device wiring instructions.

SPECIAL HANDLING

NOTE: Always use Bailey's Field Static Kit (P/N 1948385A2 - has a wrist strap, ground cord assembly, alligator clip) when working with modules. The kit connects a technician and the static dissipative work surface to the same ground point to prevent damage to the modules by electrostatic discharge.

This device uses metal oxide semiconductor (MOS) devices that require special precautions during shipping and handling. Static discharge, improper grounding, and careless handling can damage these devices. To help reduce the chance of damage, follow these procedures:

1. Keep the module in its special anti-static bag until you are ready to install it. Save the anti-static bag for future use.
2. Ground the anti-static bag before opening it.
3. Make sure all devices to which the module connects are properly grounded before connection.
4. Avoid touching the circuitry when handling the module.

NOTE: Wear the grounding straps from the field static kit when removing or installing the module to change switch settings.

UNPACKING AND INSPECTION

These are steps to follow for general handling:

1. Examine the module to make sure that no damage has occurred in transit.
2. Notify the nearest Bailey Sales/Service Office of any damage.
3. File a claim for any damage with the shipping company that handled the shipment.

4. Use the original packing material or container to store the module.
5. Store the module in a place with clean air; free of extremes of temperature and humidity.

SETUP/INSTALLATION

Before applying power to the ASI, make these checks:

1. Check that the module address is set.
2. Be sure the dipshunts in the MMU's slave expander bus and on Termination Unit (NTAI05) are installed.
3. Check that the dipswitch on Termination Module (NIAI04) is set.
4. Verify I/O cabling connections.

Slave Address Selection Switch (S1)

The ASI must have an address to communicate with the MFP. The ASI can have one of 64 addresses (address 0 to 63) on the slave expander bus. This address identifies the slave to the master module and must be the same as the address set in the master module setup data (Function Code 132 or 133 specification 1).

Set the address with the eight position address dipswitch (S1), shown in Figure 3-1. The six right switch positions (3 through 8) of S1 set the six bit address. Positions 1 and 2 must remain in the closed position. Table 3-1 is a binary address table for setting S1.

NOTE: Set contacts 1 and 2 to open. Set the address on contacts 3 through 8.

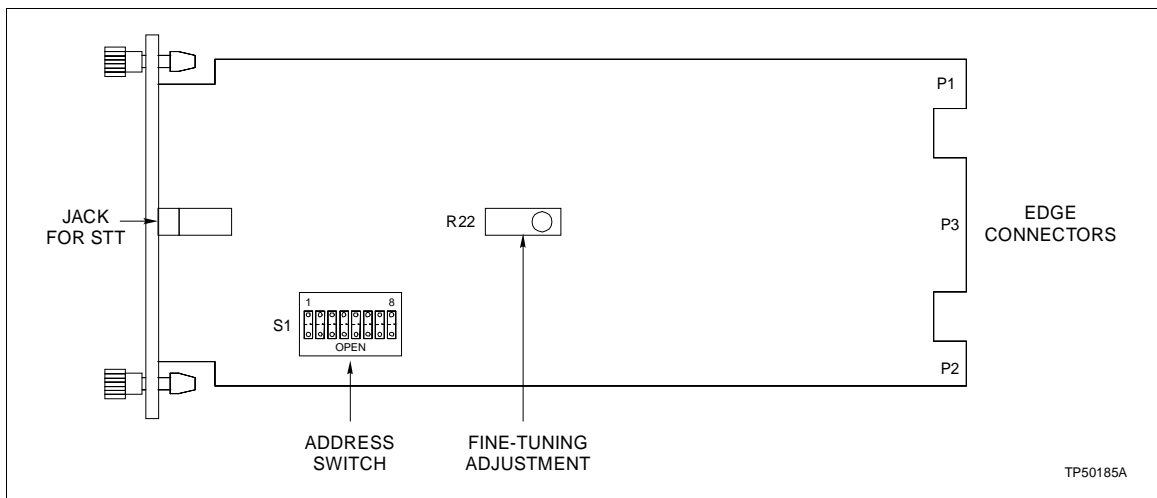

Figure 3-1. Address Select Switch (S1)

Table 3-1. Address Switch Settings (S1)

Addr	MSB						LSB						
	3	4	5	6	7	8	Addr	3	4	5	6	7	8
0	0	0	0	0	0	0	32	1	0	0	0	0	0
1	0	0	0	0	0	1	33	1	0	0	0	0	1
2	0	0	0	0	1	0	34	1	0	0	0	1	0
3	0	0	0	0	1	1	35	1	0	0	0	1	1
4	0	0	0	1	0	0	36	1	0	0	1	0	0
5	0	0	0	1	0	1	37	1	0	0	1	0	1
6	0	0	0	1	1	0	38	1	0	0	1	1	0
7	0	0	0	1	1	1	39	1	0	0	1	1	1
8	0	0	1	0	0	0	40	1	0	1	0	0	0
9	0	0	1	0	0	1	41	1	0	1	0	0	1
10	0	0	1	0	1	0	42	1	0	1	0	1	0
11	0	0	1	0	1	1	43	1	0	1	0	1	1
12	0	0	1	1	0	0	44	1	0	1	1	0	0
13	0	0	1	1	0	1	45	1	0	1	1	0	1
14	0	0	1	1	1	0	46	1	0	1	1	1	0
15	0	0	1	1	1	1	47	1	0	1	1	1	1
16	0	1	0	0	0	0	48	1	1	0	0	0	0
17	0	1	0	0	0	1	49	1	1	0	0	0	1
18	0	1	0	0	1	0	50	1	1	0	0	1	0
19	0	1	0	0	1	1	51	1	1	0	0	1	1
20	0	1	0	1	0	0	52	1	1	0	1	0	0
21	0	1	0	1	0	1	53	1	1	0	1	0	1
22	0	1	0	1	1	0	54	1	1	0	1	1	0
23	0	1	0	1	1	1	55	1	1	0	1	1	1
24	0	1	1	0	0	0	56	1	1	1	0	0	0
25	0	1	1	0	0	1	57	1	1	1	0	0	1
26	0	1	1	0	1	0	58	1	1	1	0	1	0
27	0	1	1	0	1	1	59	1	1	1	0	1	1
28	0	1	1	1	0	0	60	1	1	1	1	0	0
29	0	1	1	1	0	1	61	1	1	1	1	0	1
30	0	1	1	1	1	0	62	1	1	1	1	1	0
31	0	1	1	1	1	1	63	1	1	1	1	1	1

Termination Unit/Module Configuration

A TU/TM connects the field device wiring to the Infi 90 system. The terminal blocks are located on the TU/TM.

Set up the TU/TM to accept the analog field inputs sent to the ASI module. Refer to [Appendix A](#) or [Appendix B](#) to find the setup for your application.

Physical Installation

NOTE: [Section 3](#) provides data on to the physical installation of the slave only. For complete cable and TU/TM information, refer to Termination Unit Manual I-E93-911.

The ASI module inserts into a standard Infi 90 Module Mounting Unit (MMU) and occupies one slot.

1. Verify the slot placement of the module.

WARNING

Disconnect power before installing dipshunts for slave modules on the MMU backplane (slave expander bus). Failure to do so could result in severe or fatal shock.

AVERTISSEMENT

Couper l'alimentation avant d'installer les dipshunts sur la plaque arriere du chassis de montage de modules (MMU). Toute negligence a cet egard constitue un risque de choc pouvant entrainer des blessures graves, voire morelles.

2. Verify that a dipshunt is in the slave expander bus socket on the MMU backplane between the slave and master module.
3. Connect the hooded end of the cable from the TU/TM to the MMU backplane. To do this, insert the connector into the backplane slot in the same slot as the one assigned to the slave module. The latches should snap securely into place.
4. Align the module with the guide rails in the MMU. Carefully slide the module in until the front panel is flush with the top and bottom of the MMU frame.
5. Tighten the two captive screws on the module faceplate. (To remove the module, unscrew the module screws and gently slide out).

WIRING CONNECTIONS AND CABLING

The ASI has three card edge connectors to supply power, connect slave expander bus communication and provide analog inputs (P1, P2 and P3 respectively).

Wiring

Install the module in the MMU to connect the slave module to the power (+5, ± 15 VDC), needed to drive the circuits, at P1. It also connects P2 to the slave expander bus for communication with the master module. P1 and P2 connections require no additional wiring or cabling.

NOTE: You must install a dipshunt on the backplane of the MMU to connect the slave expander bus between the slave module and master module. Locate the modules so the bus can connect the modules or they will not communicate.

Cable Connections

The IMASIO2 uses either a NTAIO5 or NIAIO4 for termination. See Figure 3-2 to find which cables to use.

FUSING

The ASI does not have any on board fuses.

PRE-OPERATING ADJUSTMENTS

You do not have to adjust the ASI before using.

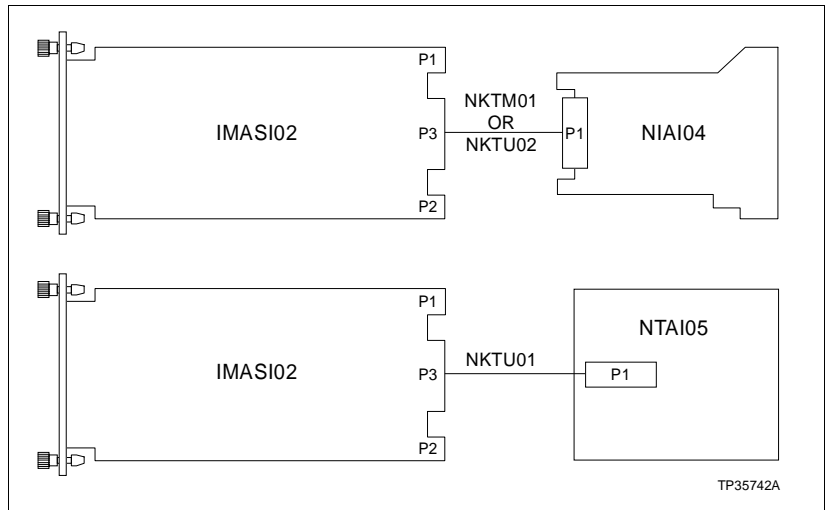

Figure 3-2. IMASI02 Cable Connections and Termination

SECTION 4 - CALIBRATION

INTRODUCTION

This section explains how to adjust the Analog Slave Input Module (IMASI02) for your system. R22 was fine tuned in the factory to provide the exact voltage for A/D conversion. If for some reason, R22 moves from its setting, follow these steps to obtain the needed accuracy. See Figure 3-1 for the location of R22.

ADJUSTING R22

This fine tuning sequence is for the 1 to 5 VDC span. Repeat these same steps for the other voltage.

1. Choose any input channel (set up in the MFP for the 1-5 Volt range).
2. Input 1.0000 VDC to the chosen channel.
3. Set the MFP to execute mode and monitor the channel in Step 1.
4. Adjust R22 until the reading is within $\pm 0.1\%$ ($\pm 0.1\%$ is ± 0.004 Volts).
5. Input 3.000 VDC.
6. Verify the voltage is within $\pm 0.1\%$. If not, adjust R22 slowly until it is within $\pm 0.1\%$.
7. Input 5.000 VDC.
8. Verify that the voltage is within $\pm 0.1\%$. If not, adjust R22 slowly until it is within $\pm 0.1\%$.
9. Verify the voltage for 1.000 VDC input can still be obtained. If it cannot, you over adjusted R22 in Steps 6 and 8. Repeat Steps 2 through 8.
10. Verify that the voltage with any other channel (the channel must be configured in the MFP for the 1-5 VDC range).
11. If the reading found for the other channel is not within ± 0.004 Volts, replace the module or contact your nearest Bailey Controls Service Representative.

SECTION 5 - OPERATING PROCEDURES

INTRODUCTION

This section explains the startup and operating procedures for the Analog Slave Input Module (IMASI02).

START-UP

Communication between the ASI and MFC starts automatically when the two modules are configured correctly. The slave address in Function Code 132 must be the same as the address set on the address dipswitch.

Upon start-up, when you apply power to the ASI and put its corresponding MFP into execute mode, all channels are marked bad quality and a Configuration Mismatch status error appears for all channels configured as smart devices. The ASI then gets all transmitter configurations (entered through Function Codes 132 and 133) from the MFC and examines the first configured channel. If it is not designated as a smart device (if Function Code 132 is associated with this channel, not Function Code 133) and there are no errors, the channel is marked good quality.

If the channel is configured as a smart device (both Function Codes 132 and 133), the ASI performs a check. It gets the actual configuration of the smart device and compares it to the configuration from the MFC. If these two configurations are equal, and no other errors have occurred, the channel is marked good quality. If there are any differences between the two configurations, the channel remains bad quality and the Configuration Mismatch status error remains. These procedures are repeated for all 15 channels.

When all 15 channels have been checked, the ASI periodically checks each channel configured as a smart device by trying to communicate with it. If a device fails to communicate, the channel is marked bad quality and the Transmitter Not Responding status error is generated for that channel. If the transmitter resumes communication at a later time, the ASI makes a configuration check (like the one made at start-up) on that channel. The ASI marks the channel as good or bad quality depending on the results of the check.

OPERATION

After the ASI completes the communication checks, commands to change the operating parameters, calibrate outputs or operate an automatic manifold can be sent to the smart

transmitters from an Infi 90 interface device. Refer to Function Code Manual I-E93-900-20 for more information on MFP Function Codes 132 -- ANALOG INPUT/SLAVE, and 133 -- SMART TRANSMITTER DEFINITION.

To enter smart transmitter commands with the hand-held STT smart transmitter terminal, plug the terminal into the adapter jack on the front panel of the ASI. See Figure 5-1 for STT adapter jack location.

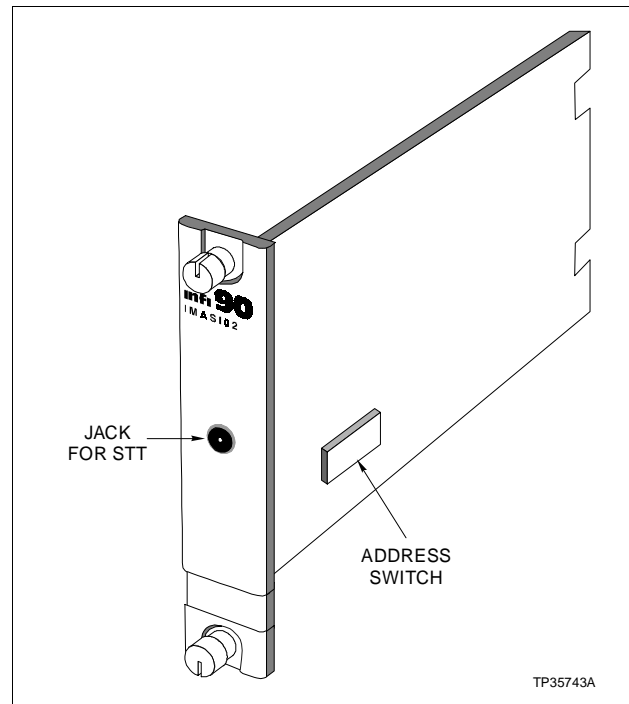

Figure 5-1. IMASIO2 Adapter Jack Location

SECTION 6 - TROUBLESHOOTING

INTRODUCTION

This section explains the error signs and corrective actions for the Analog Slave Input Module (ASI).

ERROR MESSAGES AND CORRECTIVE ACTION

You can obtain the status of the ASI by checking the master module for good quality on its input blocks. To do this, use any Infi 90 operator interface, such as an Operator Interface Station (OIS) or Configuration and Tuning Terminal (CTT).

Status Reports

The ASI monitors the smart transmitters attached to its input channels and monitors its own operation. The ASI gathers the status data and sends it to the MFP where the Infi 90 system reads it.

Access the ASI and smart transmitter status data on the OIS, CTT, and Bailey Engineering Work Station. The module summary display screen contains status reports for each module.

The module summary display screen shows the status data for specific ASI and smart transmitter errors in the I/O SLAVE status reports display. An error in the ASI or in a smart transmitter attached to the ASI causes an I/O SLAVE status report. The I/O SLAVE report contains three topics. The report lists the topics (error number code, slave address, and function block number of the ASI or smart transmitter) in this form.

I/O SLAVE ERROR NUMBER (#), SLAVE ADDRESS (#), BLOCK NUM. (#)

To figure out the error number code in the I/O SLAVE status report, check the function block to find the function code assigned to the block. If the block is an analog input/slave function code, then the I/O SLAVE status report refers to the ASI. The meanings of the error numbers are shown in Table 6-1.

Table 6-1. ASI Error Code

Error Number	Description
1	No ASI response/wrong module type
2	Calibration error (NOTE 1)
3	Channel failure/Out of range (NOTE 2)

NOTES:

1. Suggests an error in the ASI A/D calibration with the internal voltage reference.
2. Out of range refers to values of ASI inputs.

The I/O SLAVE status report lists the function blocks of I/O devices that have errors. When the function block listed is a smart transmitter definition function code, there is an error in a smart transmitter connected to an ASI. The error numbers and their definitions are shown in Table 6-2.

Table 6-2. Smart Transmitter Error Codes

Error Number	Description
1,2,3	ASI codes, refer to Table 6-1
6	Not responding
7	Not downloaded
8	Wrong transmitter type
9	Input failure
10	Over pressured
11	Temperature range exceeded
12	Output fixed
13	Manifold fixed (Output fixed by manifold command)
14	Transmitter being calibrated

Each smart transmitter attached to an ASI has its own function block to label it in the I/O SLAVE report listing for smart transmitter communication failure. Refer to [Section 2](#) for the communication lockout feature.

NOTE: If the communication lockout jumper on a smart transmitter is in the lockout position, transmitter operating parameters cannot be changed from any source, but parameters can be monitored. Refer to the product instruction manual for smart transmitter information on lockout jumpers.

Master Module Errors

The address set on address switch (S1) and in the master module setup data must be the same. The master module will signal a MISSING SLAVE MODULE error if they do not match. Check that the address set on S1 is the same as the address in

function code (FC) 132 specification 1 or function code (FC) 133 specification 1. If not:

1. Remove the module and change the setting of S1 to match the module configuration settings. Refer to [Section 3](#) to set an address and to install a slave module.

OR

1. Modify the address in the module setup data (FC 132 specification 1 or FC 133 specification 1) to match the address set on S1. Use an Infi 90 operator interface to change the setup data. Refer to the product instruction for procedures on how to change a function code specification. Refer to the product instruction manual for the operator interface you are using.

The master module will generate a MISSING SLAVE MODULE error if you fail to connect the slave expander bus between the slave module and the master module. Verify that the bus is connected on the MMU back plane.

NOTE: Set FC 132 specification 3 to 0 for the master module to **trip** when the ASI module fails. Changing specification 3 to a 1 will cause the master module to operate when a slave fails.

MODULE PIN CONNECTIONS

This section shows you the pin connections for the ASI. Check the signals on the pins and compare them to the tables. The slave module has three connection points for external signals and power (P1, P2 and P3). [Table 6-3](#) shows the pin connections for P1. [Table 6-4](#) shows the pin connections for P2. [Table 6-5](#) shows the pin connections for P3.

Table 6-3. P1 Power Pin Connections

Pin(P1)	Connection	Pin(P1)	Connection
1	+ 5 VDC	5	Common
2	+ 5 VDC	6	Common
3	NOT USED	7	+ 15 VDC
4	NOT USED	8	- 15 VDC

Table 6-4. P2 Expander Bus Connections

Pin(P2)	Signal	Pin(P2)	Signal
1	Data 1	6	Data 4
2	Data 0	7	Data 7
3	Data 3	8	Data 6
4	Data 2	9	BCLOCK
5	Data 5	10	SYNC

Table 6-5. P3 Input Signal Pin Connections

Group A		Group B	
Pin	Signal	Pin	Signal
1	INPUT 1-	A	INPUT 1+
2	INPUT 2-	B	INPUT 2+
3	INPUT 3-	C	INPUT 3+
4	INPUT 4-	D	INPUT 4+
5	INPUT 5-	E	INPUT 5+
6	INPUT 6-	F	INPUT 6+
7	INPUT 7-	H	INPUT 7+
8	INPUT 8-	J	INPUT 8+
9	INPUT 9-	K	INPUT 9+
10	INPUT 10-	L	INPUT 10+
11	INPUT 11-	M	INPUT 11+
12	INPUT 12-	N	INPUT 12+
13	INPUT 13-	P	INPUT 13+
14	INPUT 14-	R	INPUT 14+
15	INPUT 15-	S	INPUT 15+

SECTION 7 - MAINTENANCE

INTRODUCTION

The Analog Slave Input Module (IMASI02) needs little maintenance. This section contains a schedule to guide you in taking care of the system hardware. Refer questions to your local Bailey Sales Office.

MAINTENANCE SCHEDULE

Do the tasks in Table 7-1 at the times shown.

Table 7-1. Maintenance Schedule

Task	Interval
Clean and tighten each power and ground connection.	Every 6 months or at plant shut-down, whichever occurs first.
Use static safe vacuum cleaner to remove dust from: Modules Module Mounting Unit Fan Assembly Power Entry Panel	Every 6 months or at plant shut-down, whichever occurs first.

SECTION 8 - REPAIR/REPLACEMENT PROCEDURES

INTRODUCTION

This section explains the replacement steps for an Analog Slave Input Module (ASI). There are no special tools required to replace an ASI module.

MODULE REPAIR/REPLACEMENT

If the ASI is faulty, replace it with a new one. **DO NOT** try to repair the module; replacing components may affect the module performance. You can remove the module while system power is supplied. To replace a module:

1. Push and turn the two front panel captive retaining screws one half turn to unlatch the module. It is unlatched when the slots on the screws are vertical and the open end of the slots face away from the module.
2. Gently slide the module out of the MMU.
3. Configure the replacement module switch and jumper settings. Ensure they are set the same as the original module.
4. In the same slot assignment as the original module, align the replacement module with the guide rails in the MMU. Gently slide it in until the front panel is flush with the top and bottom of the MMU frame.
5. Push and turn the two captive retaining screws on the module faceplate one half turn to the latched position. It is latched when the slots on the screws are vertical and the open ends face the center of the module. (To remove the module, turn the module retaining screws to the unlatched position and gently slide out).
6. Return to normal operation.

SECTION 9 - SUPPORT SERVICES

INTRODUCTION

Bailey Controls is ready to help you use, apply and repair its products. Contact your nearest sales office to request services for sales, repair and maintenance contracts. Your sales office can answer your questions on how to apply and install the Bailey Infi 90 system. They can help you apply and install separate devices onto your system if you want to update your process or expand it.

REPLACEMENT PARTS AND ORDERING INFORMATION

When making repairs in your plant, be sure to order parts from a Bailey sales office. If you provide accurate information when ordering parts, it helps us to get the correct parts to you when you need them. Have this information ready when you call in to order parts:

1. Part description, part number and quantity.
2. Model and serial numbers.
3. Bailey instruction manual number, page number and figure that describes the part.

When you order standard parts from Bailey Controls, use part numbers and descriptions from the Recommended Spare Parts Lists. Order parts without commercial descriptions from the nearest Bailey Controls sales office.

TRAINING

Bailey Controls has a modern training complex that provides service and repair instruction. Service and repair training courses can be delivered in your plant to train your service personnel. Contact a Bailey Controls sales office for more information and to schedule training.

TECHNICAL DOCUMENTATION

You can obtain additional copies of this manual from the nearest Bailey sales office at a reasonable charge. The current manuals for all products being offered can be ordered.

APPENDIX A - TERMINATION UNIT (NTAI05) CONFIGURATION

INTRODUCTION

The Analog Slave Input Module (IMASI02) uses a NTAI05 for termination. Dipshunts on the termination unit configure the fifteen analog inputs. The ASI accepts inputs of 4-20 milliamps, 1-5 VDC, 0-1 VDC, 0-5 VDC, 0-10 VDC and -10 VDC to +10 VDC.

CONFIGURING INPUTS

Figure A-1 shows the NTAI05 dipshunt, and the analog signal path from the field device to the ASI module for a termination unit application. See Figure A-2 for the dipshunt strapping. Figure A-3 shows the terminal assignments and Figure A-4 shows the cabling for the ASI.

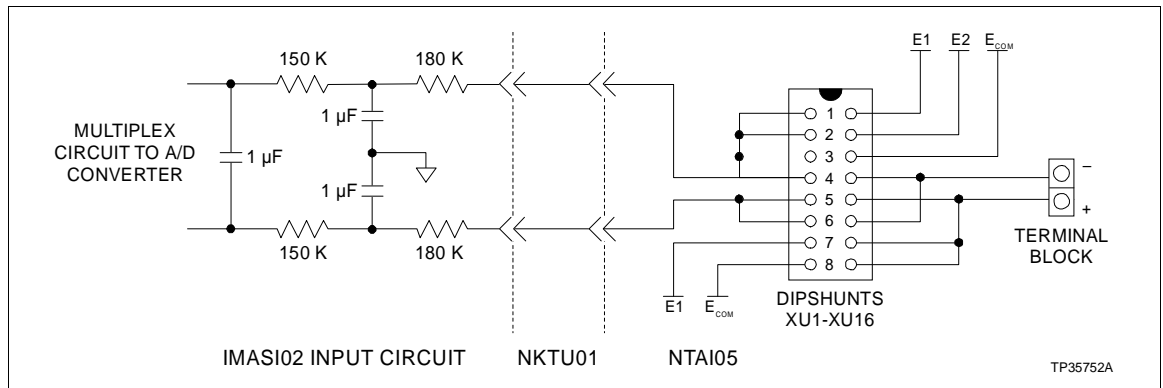

Figure A-1. Input Circuit for NTAI05

Application/Signal Type	Dipshunt Configuration ¹	Dipshunt Locations	Connecting Cable
System Powered 4-20 mA		XU1-XU16	NKTU01
Externally Powered 4-20 mA			
Signal Ended Voltage			
Differential Voltage			
Above Applications 4-20 mA 1-5 VDC 0-1 VDC 0-5 VDC 0-10 VDC ±10 VDC		XU17	

NOTES:

1. Strap one connects pin one to pin 16. Strap 3 connects pin two to pin 15 etc...
2. Terminal 16 on NTAI05 is not used. The ASI has 15 inputs.

Figure A-2. Dipshunts for NTAI05

TERMINATION UNIT (NTAI05) CONFIGURATION

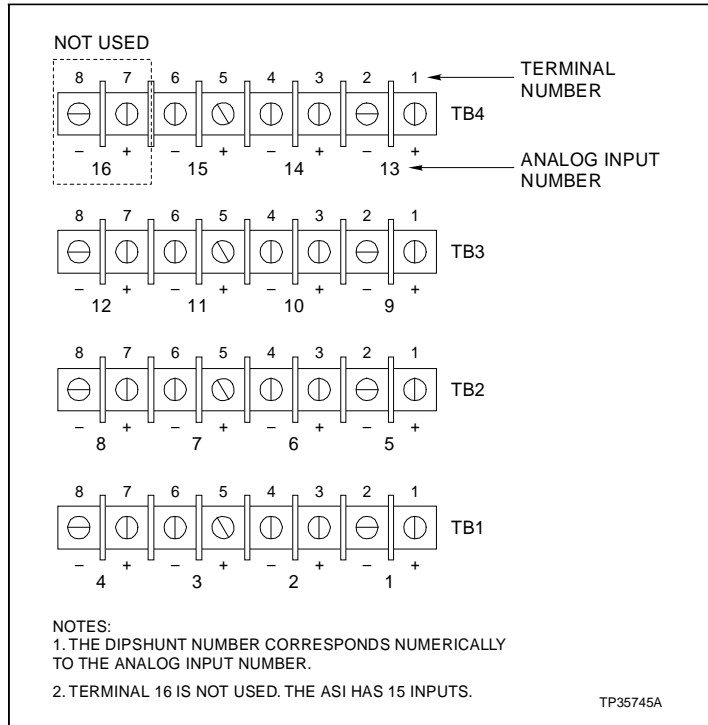

Figure A-3. Terminal Assignments for NTAI05

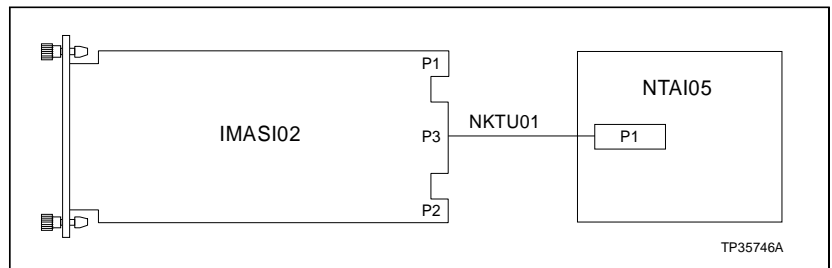

Figure A-4. Cable Connections for NTAI05

APPENDIX B - TERMINATION MODULE (NIAI04) CONFIGURATION

INTRODUCTION

The Analog Slave Input Module (IMASIO2) uses a NIAI04 for termination. Dipswitches on the NIAI04 module configure the fifteen analog inputs for the ASI slave. The ASI accepts inputs of 4-20 milliamps, 1-5 VDC, 0-1 VDC, 0-5 VDC, 0-10 VDC and -10 VDC to +10 VDC.

CONFIGURING INPUTS

Figure B-1 shows the NIAI04 and the analog signal path from the field device to the ASI module for a termination module application. The values in the figure are actual values from the devices on the module. See Figure B-2 for the dipswitch settings. Be sure to recheck the dipswitches before you install the NIAI04. The switches may be changed during handling. Figure B-3 shows the terminal assignments and Figure B-4 shows the cabling for the ASI. Figure B-2 summarizes the possible applications and dipswitch settings.

NOTE: The dipswitch analog input (AI) number AI1-AI15 corresponds numerically to the analog input number.

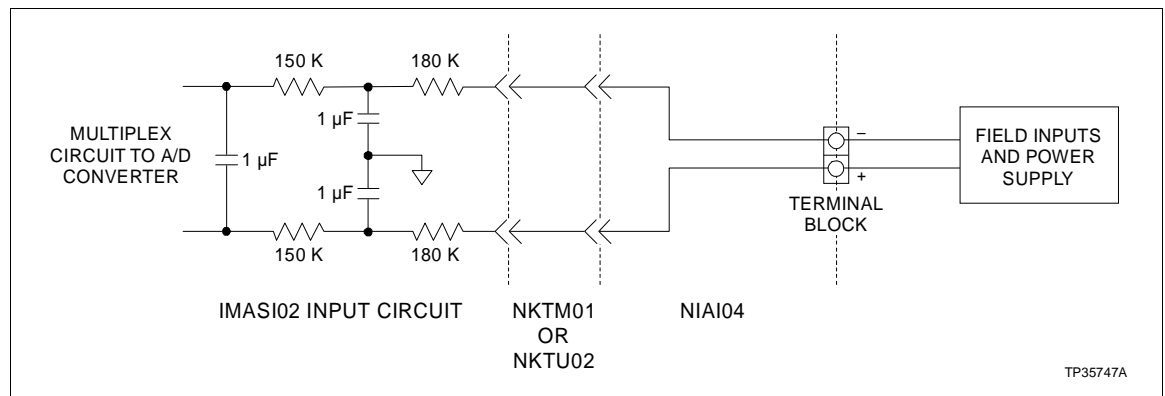
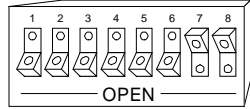
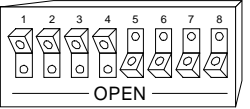
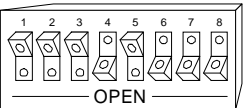
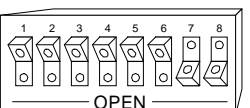
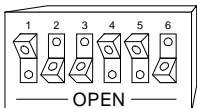

Figure B-1. Input Circuit for NIAI04

Application/Signal Type	Dipshunt Configuration ¹	Connecting Cable
System Powered		NKTU01 or NKTU02
Externally Powered		
Signal Ended Voltage		
Differential Voltage		
Above Applications 4-20 mA 1-5 VDC 0-1 VDC 0-5 VDC 0-10 VDC ±10 VDC	 <p style="text-align: right; font-size: small;">TP21512A</p>	

NOTE:

1. 1-8. represent switch positions on dipswitches S1-S15, where 0 is open and 1 is closed.

Figure B-2. Dipswitch Settings for NIAI04

Visit Elsasg Bailey on the World Wide Web at <http://www.bailey.com>

Our worldwide staff of professionals is ready to meet *your* needs for process automation.
For the location nearest you, please contact the appropriate regional office.

AMERICAS

29801 Euclid Avenue
Wickliffe, Ohio USA 44092
Telephone 1-216-585-8500
Telefax 1-216-585-8756

ASIA/PACIFIC

152 Beach Road
Gateway East #20-04
Singapore 189721
Telephone 65-391-0800
Telefax 65-292-9011

EUROPE, AFRICA, MIDDLE EAST

Via Puccini 2
16154 Genoa, Italy
Telephone 39-10-6582-943
Telefax 39-10-6582-941

GERMANY

Graefstrasse 97
D-60487 Frankfurt Main
Germany
Telephone 49-69-799-0
Telefax 49-69-799-2406

CONTACT US & SUPPORT

NEED A QUOTE OR TECHNICAL PARTS REPLACEMENT?

Company: [PLC ProTech Ltd.](#)
Website: www.plcprotech.com
Email: sales@plcprotech.com
Phone: +86 180 4631 7198

Our Service Guarantee:

- 100% Brand New Original & Factory Sealed Components
- 12-Month Quality Warranty on All Industrial Parts
- Worldwide Same-Day Fast Dispatch via DHL / FedEx

[SUBMIT ONLINE RFQ \(REQUEST FOR QUOTE\) >>](#)

[About Us](#) · [Contact](#) · [All Products](#)