

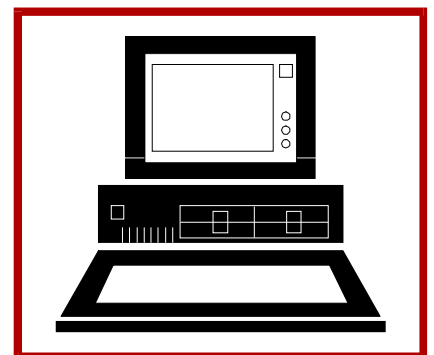

E96-203

Instruction

Multi-Function Processor Module (IMMFP03/IMMFP03B)

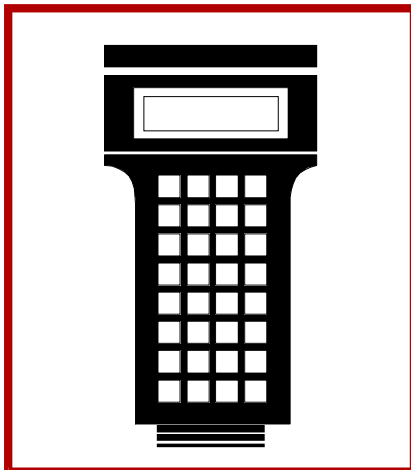
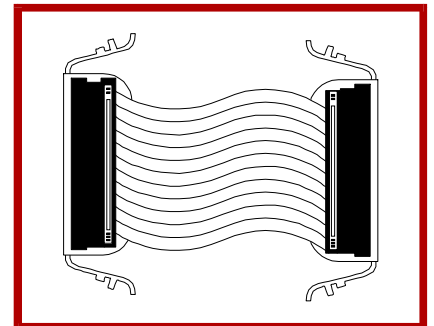
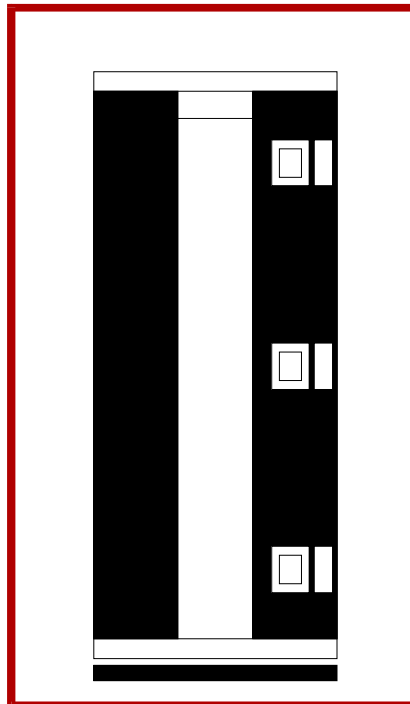
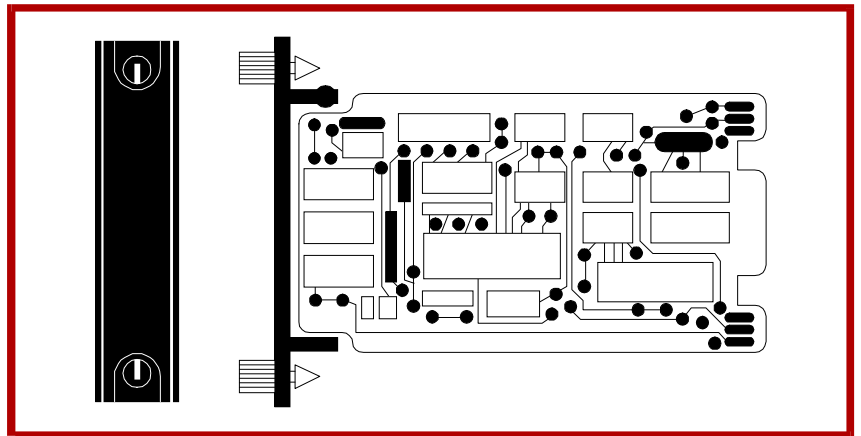
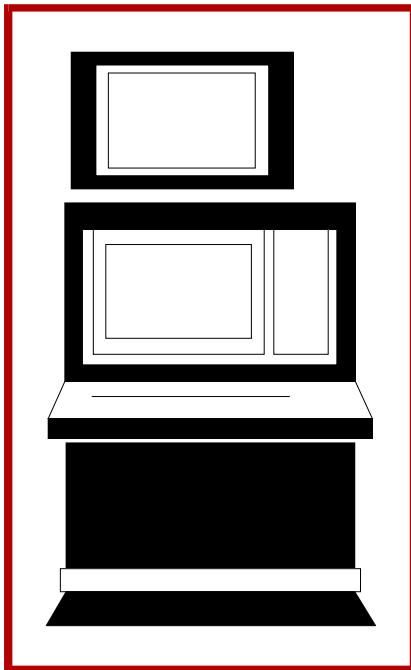

WARNING notices as used in this instruction apply to hazards or unsafe practices that could result in personal injury or death.

CAUTION notices apply to hazards or unsafe practices that could result in property damage.

NOTES highlight procedures and contain information that assists the operator in understanding the information contained in this instruction.

WARNING

INSTRUCTION MANUALS

DO NOT INSTALL, MAINTAIN, OR OPERATE THIS EQUIPMENT WITHOUT READING, UNDERSTANDING, AND FOLLOWING THE PROPER **Elsag Bailey** INSTRUCTIONS AND MANUALS; OTHERWISE, INJURY OR DAMAGE MAY RESULT.

RADIO FREQUENCY INTERFERENCE

MOST ELECTRONIC EQUIPMENT IS INFLUENCED BY RADIO FREQUENCY INTERFERENCE (RFI). CAUTION SHOULD BE EXERCISED WITH REGARD TO THE USE OF PORTABLE COMMUNICATIONS EQUIPMENT IN THE AREA AROUND SUCH EQUIPMENT. PRUDENT PRACTICE DICTATES THAT SIGNS SHOULD BE POSTED IN THE VICINITY OF THE EQUIPMENT CAUTIONING AGAINST THE USE OF PORTABLE COMMUNICATIONS EQUIPMENT.

POSSIBLE PROCESS UPSETS

MAINTENANCE MUST BE PERFORMED ONLY BY QUALIFIED PERSONNEL AND ONLY AFTER SECURING EQUIPMENT CONTROLLED BY THIS PRODUCT. ADJUSTING OR REMOVING THIS PRODUCT WHILE IT IS IN THE SYSTEM MAY UPSET THE PROCESS BEING CONTROLLED. SOME PROCESS UPSETS MAY CAUSE INJURY OR DAMAGE.

AVERTISSEMENT

MANUELS D'OPÉRATION

NE PAS METTRE EN PLACE, RÉPARER OU FAIRE FONCTIONNER L'ÉQUIPEMENT SANS AVOIR LU, COMPRIS ET SUIVI LES INSTRUCTIONS RÉGLEMENTAIRES DE **Elsag Bailey**. TOUTE NÉGLIGENCE À CET ÉGARD POURRAIT ÊTRE UNE CAUSE D'ACCIDENT OU DE DÉFAILLANCE DU MATÉRIEL.

PERTURBATIONS PAR FRÉQUENCE RADIO

LA PLUPART DES ÉQUIPEMENTS ÉLECTRONIQUES SONT SENSIBLES AUX PERTURBATIONS PAR FRÉQUENCE RADIO. DES PRÉCAUTIONS DEVRONT ÊTRE PRISES LORS DE L'UTILISATION DU MATÉRIEL DE COMMUNICATION PORTATIF. LA PRUDENCE EXIGE QUE LES PRÉCAUTIONS À PRENDRE DANS CE CAS SOIENT SIGNALÉES AUX ENDROITS VOULUS DANS VOTRE USINE.

PERTURBATIONS DU PROCÉDÉ

L'ENTRETIEN DOIT ÊTRE ASSURÉ PAR UNE PERSONNE QUALIFIÉE EN CONSIDÉRANT L'ASPECT SÉCURITAIRE DES ÉQUIPEMENTS CONTRÔLÉS PAR CE PRODUIT. L'AJUSTEMENT ET/OU L'EXTRACTION DE CE PRODUIT PEUT OCCASIONNER DES À-COUPS AU PROCÉDÉ CONTRÔLE LORSQU'IL EST INSÉRÉ DANS UNE SYSTÈME ACTIF. CES À-COUPS PEUVENT ÉGALEMENT OCCASIONNER DES BLESSURES OU DES DOMMAGES MATÉRIELS.

NOTICE

The information contained in this document is subject to change without notice.

Elsag Bailey, its affiliates, employees, and agents, and the authors and contributors to this publication specifically disclaim all liabilities and warranties, express and implied (including warranties of merchantability and fitness for a particular purpose), for the accuracy, currency, completeness, and/or reliability of the information contained herein and/or for the fitness for any particular use and/or for the performance of any material and/or equipment selected in whole or part with the user of/or in reliance upon information contained herein. Selection of materials and/or equipment is at the sole risk of the user of this publication.

This document contains proprietary information of Elsag Bailey, Elsag Bailey Process Automation, and is issued in strict confidence. Its use, or reproduction for use, for the reverse engineering, development or manufacture of hardware or software described herein is prohibited. No part of this document may be photocopied or reproduced without the prior written consent of Elsag Bailey.

Preface

The IMMFP03 and IMMFP03B Multi-Function Processor Modules are powerful stand-alone process controllers for use in complex control applications. They have the processing speed and storage capabilities necessary for advanced control applications. The IMMFP03 module is a user-configurable device that receives process input and output through a variety of analog and digital I/O modules. The IMMFP03B module has the same function as the IMMFP03 module and has more memory. The IMMPIO1 Multi-Function Processor Interface Module is an I/O module that provides serial channels for the IMMFP03 and IMMFP03B modules.

This instruction provides information about how the IMMFP03 and IMMFP03B modules work, and how they are installed and configured. It also contains operating and troubleshooting procedures. This instruction discusses the IMMFP03 and IMMFP03B modules together since they are similar. Differences are noted as they occur. The reader is presumed to have some process control background.

List of Effective Pages

Total number of pages in this instruction is 82, consisting of the following:

Page No.	Change Date
Preface	Original
List of Effective Pages	Original
iii through viii	Original
1-1 through 1-6	Original
2-1 through 2-7	Original
3-1 through 3-13	Original
4-1 through 4-5	Original
5-1 through 5-12	Original
6-1 through 6-3	Original
7-1 through 7-2	Original
8-1	Original
A-1 through A-5	Original
B-1 through B-7	Original
C-1 through C-5	Original
D-1 through D-6	Original
Index-1 through Index-2	Original

When an update is received, insert the latest changed pages and dispose of the superseded pages.

NOTE: On an update page, the changed text or table is indicated by a vertical bar in the outer margin of the page adjacent to the changed area. A changed figure is indicated by a vertical bar in the outer margin next to the figure caption. The date the update was prepared will appear beside the page number.

Safety Summary

GENERAL WARNINGS

Equipment Environment

All components, whether in transportation, operation or storage, must be in a noncorrosive environment.

Electrical Shock Hazard During Maintenance

Disconnect power or take precautions to insure that contact with energized parts is avoided when servicing.

Special Handling

This module uses electrostatic sensitive devices.

SPECIFIC WARNINGS

Disconnect power before installing dipshunts on the module mounting unit backplane. Failure to do so will result in contact with cabinet areas that could cause severe or fatal shock. (p. 3-10)

Wear eye protection whenever working with cleaning solvents. When removing solvents from printed circuit boards using compressed air, injury to the eyes could result from splashing solvent as it is removed from the printed circuit board. (p. 6-1)

SPECIFIC CAUTIONS

Never operate the MFP module with the machine fault timer circuit disabled (jumper pins connected). Unpredictable module outputs and configuration corruption may result. The unpredictable module outputs may damage control equipment connected to the MFP module. (p. 3-12)

To avoid potential module damage, evaluate your system for compatibility prior to module installation. This module uses connections to the module mounting unit backplane that served other functions in early Network 90 systems. (p. 3-12)

Sommaire de Sécurité

AVERTISSEMENTS D'ORDRE GÉNÉRAL

Environnement de l'équipement

Ne pas soumettre les composants à une atmosphère corrosive lors du transport, de l'entreposage ou l'utilisation.

Possibilité de chocs électriques durant l'entretien

Débrancher l'alimentation ou prendre les précautions pour éviter tout contact avec des composants sous tension durant l'entretien.

Precautions de Manutention

Ce module contient des composantes sensibles aux decharges electro-statiques.

AVERTISSEMENTS D'ORDRE SPÉCIFIQUE

Interrompez l'alimentation avant d'installer des dipshunts sur le fond de panier du châssis de montage des modules. Sinon, tout contact avec cette zone entraîne des risques d'électrocution sérieuse ou fatale. (p. 3-10)

Des lunettes de protection devraient être portées lors de travail avec des solvants nettoyants. Lorsqu'on enlève les solvants des circuits imprimés à l'aide d'air comprimé, les éclaboussures de solvant pourraient causer des blessures aux yeux. (p. 6-1)

ATTENTIONS D'ORDRE SPÉCIFIQUE

N'utilisez jamais un module MFP sans l'usage de sa minuterie de détection de défaillance (c'est à dire avec le cavalier en place). Les sorties du module pourraient prendre des valeurs ou des états imprévisibles, et la configuration pourrait être corrompue. Le comportement imprévisible des sorties pourrait endommager le matériel de commande relié au module MFP. (p. 3-12)

Pour éviter d'endommager des modules, évaluez la compatibilité de votre système avant de les y brancher. L'usage que fait ce module de certaines connexions au fond de panier du châssis de montage diffère de l'assignation prévue par le système Network 90 original. (p. 3-12)

Table of Contents

	<i>Page</i>
SECTION 1 - INTRODUCTION.....	1-1
OVERVIEW	1-1
INTENDED USER	1-1
HARDWARE DESCRIPTION	1-1
Faceplate	1-2
Circuit Board	1-3
HARDWARE APPLICATION	1-3
FEATURES.....	1-3
INSTRUCTION CONTENT.....	1-3
HOW TO USE THIS INSTRUCTION.....	1-4
GLOSSARY OF TERMS AND ABBREVIATIONS	1-4
REFERENCE DOCUMENTS	1-5
NOMENCLATURE.....	1-5
SPECIFICATIONS	1-6
SECTION 2 - DESCRIPTION AND OPERATION.....	2-1
INTRODUCTION	2-1
MFP MODULE OPERATION	2-1
MFP MODULE CIRCUITRY.....	2-2
Microprocessor.....	2-2
Clock and Real Time Clock	2-3
Memory.....	2-3
Direct Memory Access	2-3
Controlway.....	2-4
Redundancy Link	2-4
I/O Expander Bus	2-5
I/O Section	2-5
MPI MODULE OPERATION	2-5
MPI MODULE CIRCUITRY	2-6
Serial Channels (DUART).....	2-6
Station Link	2-7
SECTION 3 - INSTALLATION.....	3-1
INTRODUCTION	3-1
SPECIAL HANDLING	3-1
UNPACKING AND INSPECTION.....	3-2
IMMFP03 DIPSWITCHES AND JUMPERS	3-2
Dipswitch UUB0 - Module Address	3-3
Dipswitch UMB1 - Module Options and Diagnostics	3-4
Special Operations	3-5
Dipswitch LMB2 - Module Options and SCSI Bus Address	3-6
Dipswitch LLB3 - Module Options.....	3-7
Jumpers J1, J2, J4 and J5	3-7
HW SETUP Socket Jumper	3-8
IMMPIO1 JUMPER SETTINGS	3-8
PREPARING THE MODULE MOUNTING UNIT	3-9
Module Slot Assignments	3-9
Dipshunts.....	3-10
Controlway Cable	3-10
INSTALLING THE TERMINATION UNIT OR MODULE AND FIELD WIRING	3-11
NTMP01 Termination Unit Installation	3-11
NIMP01 or NIMP02 Termination Module Installation	3-11
INSTALLING THE MODULES	3-12

Table of Contents (continued)

	<i>Page</i>
SECTION 4 - OPERATING PROCEDURES	4-1
INTRODUCTION	4-1
MFP MODULE START-UP	4-1
MFP MODULE LEDs	4-1
Front Panel LEDs	4-2
Red/Green Status LED	4-3
MFP MODULE STOP/RESET SWITCH	4-3
MFP MODULE MODES OF OPERATION	4-4
Configure Mode	4-4
Execute Mode	4-4
Error Mode	4-4
MPI MODULE OPERATION	4-5
MPI MODULE LED	4-5
SECTION 5 - TROUBLESHOOTING	5-1
INTRODUCTION	5-1
CARD EDGE CONNECTORS	5-5
DIAGNOSTICS	5-7
Overview	5-7
Dipswitch Selection	5-8
LED Display	5-10
IMMFP03 MODULE STATUS SUMMARY	5-11
SECTION 6 - MAINTENANCE	6-1
INTRODUCTION	6-1
PREVENTIVE MAINTENANCE SCHEDULE	6-1
EQUIPMENT AND TOOLS REQUIRED	6-2
PREVENTIVE MAINTENANCE PROCEDURES	6-2
Printed Circuit Board Cleaning	6-2
General Cleaning and Washing	6-2
Edge Connector Cleaning	6-3
Checking Connections	6-3
SECTION 7 - REPAIR/REPLACEMENT PROCEDURES	7-1
INTRODUCTION	7-1
MODULE REPLACEMENT PROCEDURE	7-1
TERMINATION UNIT OR MODULE REPLACEMENT PROCEDURES	7-2
SECTION 8 - SUPPORT SERVICES	8-1
INTRODUCTION	8-1
REPLACEMENT PARTS AND ORDERING INFORMATION	8-1
TRAINING	8-1
TECHNICAL DOCUMENTATION	8-1
APPENDIX A - QUICK REFERENCE MATERIAL	A-1
INTRODUCTION	A-1
APPENDIX B - ON-LINE CONFIGURATION	B-1
INTRODUCTION	B-1
SETUP	B-1

Table of Contents (continued)

	<i>Page</i>
<hr/>	
APPENDIX B - ON-LINE CONFIGURATION (continued)	
OPERATION	B-1
Backup Cycle	B-3
Primary Cycle.....	B-6
<hr/>	
APPENDIX C - NTMP01 CONFIGURATION	C-1
INTRODUCTION	C-1
<hr/>	
APPENDIX D - NIMP01 AND NIMP02 CONFIGURATION	D-1
INTRODUCTION	D-1
<hr/>	

List of Figures

<i>No.</i>	<i>Title</i>	<i>Page</i>
1-1.	Example IMMFP03 and IMMPIO1 Application	1-2
2-1.	MFP Functional Block Diagram	2-2
2-2.	MPI Functional Block Diagram	2-6
3-1.	Multi-Function Processor Module Layout	3-3
3-2.	IMMPIO1 Jumper Locations	3-8
3-3.	IMMPIO1 Jumper J1 Settings.....	3-9
3-4.	IMMPIO1 Jumper J2 Settings.....	3-9
3-5.	Controlway Cable Installation	3-10
4-1.	MFP Front Panel	4-2
4-2.	MPI Front Panel	4-5
5-1.	MFP Troubleshooting Flowchart (Serial Port)	5-4
5-2.	MFP Troubleshooting Flowchart (Status LED)	5-5
5-3.	Diagnostic Dipswitch Positions	5-8
5-4.	LEDs - Pass/Fail	5-10
B-1.	Backup MFP Module Operating Cycle	B-5
B-2.	Primary MFP Module Operating Cycle	B-7
C-1.	NTMP01 DTE Jumper Configuration	C-1
C-2.	NTMP01 DCE Jumper Configuration.....	C-2
C-3.	NTMP01 Nonhandshake Jumper Configuration	C-2
C-4.	NTMP01 Loopback Jumper Configuration	C-3
C-5.	NTMP01 Jumpers J3 through J10 Configuration	C-3
C-6.	NTMP01 Jumpers J14 through J17 Configuration.....	C-4
C-7.	NTMP01 Connector Assignments and Jumper Locations	C-4
C-8.	NTMP01 Cable Connections for Redundant IMMFP03 and IMMPIO1 Modules	C-5
D-1.	NIMP01 DTE Jumper Configuration	D-2
D-2.	NIMP01 DCE Jumper Configuration	D-2
D-3.	NIMP01 Nonhandshake Jumper Configuration	D-2
D-4.	NIMP01 Loopback Jumper Configuration	D-3
D-5.	NIMP01 Jumpers J5 through J10 Configuration	D-3
D-6.	NIMP01 Jumpers J14 through J17 Configuration	D-4
D-7.	NIMP01 Connector Assignments and Jumper Locations	D-4
D-8.	NIMP01 Cable Connections for Single MFP and MPI Modules	D-5
D-9.	NIMP01 and NIMP02 Cable Connections for Redundant MFP and MPI Modules ..	D-6

List of Tables

<i>No.</i>	<i>Title</i>	<i>Page</i>
1-1.	Glossary of Terms and Abbreviations	1-4
1-2.	Reference Documents	1-5
1-3.	Nomenclature	1-5
1-4.	Specifications	1-6
3-1.	Dipswitch UUB0 Settings for MFP Operation	3-4
3-2.	Dipswitch UUB0 Settings for MFP Address	3-4
3-3.	Dipswitch UMB1 Options and Diagnostics	3-4
3-4.	Dipswitch UMB1 Special Operation Settings	3-5
3-5.	Dipswitch LLB3 Option Settings	3-7
3-6.	Jumpers J1, J2, J4 and J5 Settings	3-7
3-7.	HW SETUP Socket Jumper Settings	3-8
5-1.	IMMFP03 Error Codes	5-1
5-2.	Other MFP Module Conditions	5-3
5-3.	MFP Connector P1 Pin Assignments	5-5
5-4.	MFP Connector P2 Pin Assignments	5-6
5-5.	MFP Connector P3 Pin Assignments	5-6
5-6.	MFP Connector P4 Pin Assignments	5-6
5-7.	MPI Connector P1 Pin Assignments	5-6
5-8.	MPI Connector P3 Pin Assignments	5-7
5-9.	DSO and MFP Setup for I/O Expander Bus Test	5-8
5-10.	Diagnostic Tests	5-9
5-11.	IMMFP03 Status Report	5-11
5-12.	Field Descriptions of the MFP Status Report	5-12
6-1.	Preventive Maintenance Schedule	6-2
8-1.	Spare Parts List	8-1
A-1.	Dipswitch UUB0 Settings for MFP Operation	A-1
A-2.	Dipswitch UUB0 Settings for MFP Address	A-1
A-3.	Dipswitch UMB1 Options and Diagnostics	A-1
A-4.	Dipswitch UMB1 Special Operation Settings	A-2
A-5.	Dipswitch LLB3 Option Settings	A-2
A-6.	Jumpers J1, J2, J4 and J5 Settings	A-3
A-7.	HW SETUP Socket Jumper Settings	A-3
A-8.	Front Panel LED Error Codes	A-3
A-9.	Other LED Conditions	A-5
B-1.	Legend of Symbols	B-2
B-2.	Backup Cycle	B-3
B-3.	Primary Cycle	B-6

SECTION 1 - INTRODUCTION

OVERVIEW

The IMMFP03 and IMMFP03B Multi-Function Processor Modules are powerful and advanced INFI 90® processor modules capable of handling the most demanding process control applications. They are stand-alone controllers that can handle specific control and information processing applications in addition to multiple-loop analog, sequential, and batch control. They have the power to execute demanding process control applications that are data intensive, program intensive or both. Because of the similarity of the IMMFP03 and IMMFP03B Multi-Function Processor Modules, they are referred to as IMMFP03 modules in this instruction. Differences are noted as they occur.

The INFI 90 system uses a variety of analog and digital I/O modules to interface with the process. The multi-function processor (MFP) module communicates with a maximum of 64 I/O modules in any combination (Fig. 1-1). For added reliability, the MFP module has circuitry that supports redundancy. A backup MFP module waits in a standby mode while the primary module executes. If the primary goes off-line for any reason, there is a bumpless transfer of control to the backup module.

Serial channels are available to the MFP module through the use of an auxiliary I/O module that attaches to it. The IMMPIO1 Multi-Function Processor Interface Module gives the MFP module access to an IISAC01 Analog Control Station (SAC) or NDCS03 Digital Control Station (DCS) link, and two serial ports.

INTENDED USER

Personnel installing, operating or maintaining the MFP module should read this instruction before performing any installation, operation or maintenance procedures. Installation requires an engineer or technician with experience handling electronic circuitry. Formal training in INFI 90 systems and configuration (especially function codes) would help when configuring the MFP module.

HARDWARE DESCRIPTION

The IMMFP03 Multi-Function Processor Module consists of a circuit board and faceplate.

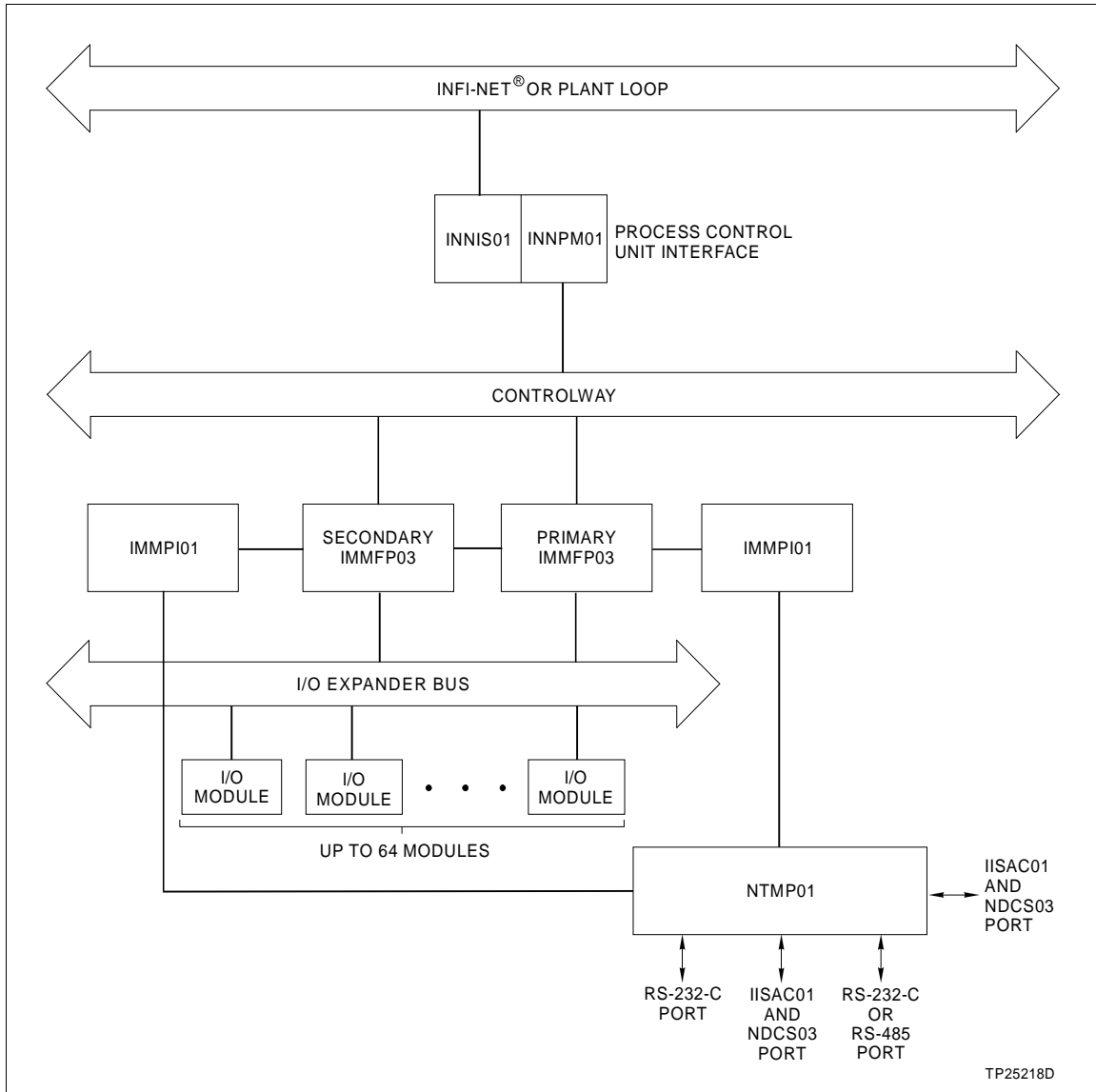

Figure 1-1. Example IMMFP03 and IMMPIO1 Application

Faceplate

The MFP faceplate measures 35.56 millimeters wide by 177.80 millimeters high (1.4 inches wide by 7.0 inches high). Two latching screws, one at the top, the other at the bottom, lock the module assembly in the module mounting unit. A transparent window on the faceplate enables viewing the 16 CPU LEDs and the status LED. These LEDs display operating information. A small hole directly below the window provides access to the combination stop/reset pushbutton. Besides locking the module in place, the faceplate also protects the circuit components and promotes proper air flow within the cabinet.

© INFI-NET is a registered trademark of Elsag Bailey Process Automation.

Circuit Board

The circuit board features state-of-the-art circuitry. On the board are nonvolatile random access memory (NVRAM), static random access memory (SRAM), read only memory (ROM), a microprocessor running at 32 megahertz, direct memory access (DMA) circuits, Elsag Bailey custom bus circuits and various support circuitry. The board attaches to the faceplate with two screws. The module assembly occupies one slot in a module mounting unit. An adjacent slot to the left of the MFP module is required for the optional I/O module.

HARDWARE APPLICATION

Because of the superior performance of the MFP module, applications that formerly required an external mainframe or minicomputer can now be handled in the process control unit. The large memory space and on-board communication ports of the MFP module enable it to meet the sophisticated control application requirements of supervisory control, optimization routines, performance assessment and process modeling.

FEATURES

The MFP module contains a high speed redundancy link, auto/DMA mode of operation for the I/O expander bus, and a 32-bit data path to any memory. On-board SRAM memory is two megabytes for the IMMFP03 module and eight megabytes for the IMMFP03B module.

The IMMFP03 and IMMFP03B modules can utilize an optional auxiliary I/O module or IMMPIO1 Multi-Function Processor Interface Module. I/O includes two serial channels and a station link for up to 64 analog control stations or eight digital control stations. The control station link is DMA driven.

INSTRUCTION CONTENT

This instruction contains eight sections and four appendices.

Introduction	Provides an overview of the module, a description of the hardware, a glossary of unique terms and a table of physical, electrical and environmental specifications.
Description and Operation	Uses block diagrams to explain the function of the key circuits.
Installation	Explains the handling, inspection, hardware configuration and installation aspects of the module.
Operating Procedures	Discusses the front panel indicators and controls, and everyday operation.

- Troubleshooting** Features detailed flowcharts and tables that enable quick diagnosis of error conditions and provides corrective actions.
- Maintenance** Covers scheduled module maintenance.
- Repair/Replacement Procedures** Describes how to repair and replace the module.
- Support Services** Explains how to order parts, schedule training and receive technical documentation.
- Appendices** Provide quick reference information for the hardware configuration of the IMMFP03 module and associated termination units and modules, and step-by-step instructions for performing on-line configuration.

HOW TO USE THIS INSTRUCTION

Read this instruction in sequence. To get the best use out of this instruction, read it from cover to cover, then go back to specific sections as required. Elsag Bailey strongly advises against putting the module into operation until the installation section has been read and performed.

1. Read and perform all steps in the installation section.
2. Thoroughly read the operating procedures section before applying power to the module.
3. Refer to the troubleshooting section if a problem occurs. This section will help to diagnose and correct a problem.
4. Go to the repair and replacement procedures section to find instructions on how to replace the module.
5. Refer to the support services section for replacement part and warranty information.

GLOSSARY OF TERMS AND ABBREVIATIONS

Table 1-1 contains those terms and abbreviations that are unique to Elsag Bailey or have a definition that is different from standard industry usage.

Table 1-1. Glossary of Terms and Abbreviations

Term	Definition
I/O Expander Bus	Parallel communication bus between the control and I/O modules.
MFP	Multi-function processor module. A multiple loop controller with data acquisition and information processing capabilities.
MFT	Machine fault timer. Reset by the processor during normal operation. If not reset regularly, the MFT times out and the module stops.

Table 1-1. Glossary of Terms and Abbreviations (continued)

Term	Definition
MMU	Module mounting unit. A card cage that provides electrical and communication support for INFI 90/Network 90® modules.
Module Bus	Peer-to-peer communication link used to transfer information between intelligent modules within a process control unit.
SAC	Analog control station.
Termination Module	Provides input/output connection between plant equipment and the INFI 90/Network 90 modules.
Termination Unit	

REFERENCE DOCUMENTS

Table 1-2 contains a list of reference documents that provide information on MFP firmware and related hardware.

Table 1-2. Reference Documents

Number	Title
I-E96-117	IISAC01 Analog Control Station
I-E96-200	Function Code Application Manual
I-E96-313	IMDSO04 Digital Slave Output Module
I-E96-401	NIMP01/02 Multi-Function Processor Termination Module
I-E96-428	NTMP01 Multi-Function Processor Termination Unit

NOMENCLATURE

Table 1-3 lists nomenclature related to the IMMFP03 module.

Table 1-3. Nomenclature

Nomenclature	Description
IISAC01	Analog control station
IMMFP03/03B	Multi-function processor module
IMMPI01	Multi-function processor interface module
NDCS03	Digital control station
NIMP01/02	Multi-function processor module termination module
NKMP03	Redundant multi-function processor ribbon cable
NKMR02	Station serial extension adapter cable DB-9 to DB-25
NKSE01	Serial extension cable (PVC)
NKSE11	Serial extension cable (non-PVC)
NKTU01	Termination unit cable (PVC)
NKTU02	Termination module cable (PVC)
NKTU11	Termination unit cable (non-PVC)
NKTU12	Termination module cable (non-PVC)
NTMP01	Multi-function processor module termination unit

® Network 90 is a registered trademark of Elsag Bailey Process Automation.

SPECIFICATIONS

Table 1-4 lists the specifications for the IMMFP03 and IMMFP03B Multi-Function Processor Modules, and IMMPIO1 Multi-Function Processor Interface Module.

Table 1-4. Specifications

Property	Characteristic/Value																						
IMMFP03/IMMFP03B																							
Microprocessor	32-bit processor running at 32 MHz																						
Memory	All memory has 32-bit data path																						
	<table border="1"> <thead> <tr> <th rowspan="2">Module</th> <th colspan="2">SRAM</th> <th colspan="2">NVRAM</th> <th rowspan="2">ROM Total</th> </tr> <tr> <th>Total</th> <th>Available</th> <th>Total</th> <th>Available</th> </tr> </thead> <tbody> <tr> <td>IMMFP03</td> <td>2 Mb</td> <td>1.57 Mb</td> <td>512 kb</td> <td>441 kb</td> <td>512 kb</td> </tr> <tr> <td>IMMFP03B</td> <td>8 Mb</td> <td>7.8 Mb</td> <td>2 Mb</td> <td>1.8 Mb</td> <td>512 kb</td> </tr> </tbody> </table>	Module	SRAM		NVRAM		ROM Total	Total	Available	Total	Available	IMMFP03	2 Mb	1.57 Mb	512 kb	441 kb	512 kb	IMMFP03B	8 Mb	7.8 Mb	2 Mb	1.8 Mb	512 kb
Module	SRAM		NVRAM		ROM Total																		
	Total	Available	Total	Available																			
IMMFP03	2 Mb	1.57 Mb	512 kb	441 kb	512 kb																		
IMMFP03B	8 Mb	7.8 Mb	2 Mb	1.8 Mb	512 kb																		
Power requirements	+5 VDC at 2 A; 10 W typical																						
Station support	64 40-kbaud serial stations (IISAC01) or 8 5-kbaud serial stations (NDCS03)																						
Redundant communication link	8 Mbytes parallel (maximum) 4 Mbytes (normal operation)																						
Programmability	C, Basic, Batch, Ladder, function blocks and user-defined functions																						
Dimensions	35.56 mm wide (1.40 in.), 177.80 mm high (7.00 in.), 298.45 mm long (11.75 in.)																						
Weight	0.84 kg (1 lb, 13.5 oz)																						
IMMPIO1																							
Power requirements	+5 VDC at 415 mA; 2.075 W typical																						
Communication ports	2 RS-232-C or 1 RS-232-C and 1 RS-485 1 SAC/DCS channel (64 SACs or 8 DCSs maximum)																						
Dimensions	35.56 mm wide (1.40 in.), 177.80 mm high (7.00 in.), 298.45 mm long (11.75 in.)																						
Weight	0.24 kg (8.5 oz)																						
IMMFP03/IMMFP03B/IMMPIO1																							
Electromagnetic/radio frequency interference	Values not available at this time. Keep cabinet doors closed. Do not use communication equipment any closer than 2 m from the cabinet.																						
Environmental																							
Ambient temperature	0° to 70°C (32° to 158°F)																						
Relative humidity	0% to 95% relative humidity up to 55°C (131°F) noncondensing 0% to 45% relative humidity at 70°C (158°F) noncondensing																						
Atmospheric pressure	Sea level to 3 km (1.86 mi)																						
Certification	CSA certified for use as process control equipment in ordinary (nonhazardous) locations																						

SPECIFICATIONS SUBJECT TO CHANGE WITHOUT NOTICE.

SECTION 2 - DESCRIPTION AND OPERATION

INTRODUCTION

This section explains the functionality of the IMMFP03 Multi-Function Processor Module and IMMPIO1 Multi-Function Processor Interface Module using block diagrams and text. Block diagrams divide the operation of the multi-function processor (MFP) and multi-function processor interface (MPI) modules into a series of functional blocks.

MFP MODULE OPERATION

The IMMFP03 module incorporates the power of a second generation 32-bit microprocessor operating at 32 megahertz. This is coupled with 32-bit wide memory design with an optimized interface. The microprocessor supplies superior performance capable of supplanting the need for external mainframes or minicomputers.

I/O is available from modules using the standard INFI 90 I/O expander bus or from other control modules via the Controlway. The data within the IMMFP03 module may be exported to the Plant Loop or INFI-NET plant communication systems.

In some processes, the effects of a control failure in the system can create dangerous situations or cause economic loss. To reduce the possibility of these problems occurring, redundant modules provide fail-safe control. Redundant MFP modules link directly to each other to keep the database in the backup module current. Each module uses a redundant high speed communication channel to accomplish this function. If the primary module fails, the backup module is waiting in standby mode and immediately takes over. The backup module has the same control strategy loaded in its memory as the primary MFP module and is ready to assume control. The redundant communication channel insures that single point failures will not prevent the backup module from being in a state of readiness to take over.

While the MFP module is controlling a process, it also executes diagnostic routines. It is constantly checking the integrity of its hardware and firmware during normal operation. If the diagnostic routines discover a module hardware or software problem, it makes that information available to the operator. The operator has access to this information through status LEDs on the module faceplate and through reports received on the operator interface (i.e., module status bytes).

The MFP module uses an I/O module to utilize two RS-232-C ports and a serial station link. This module, the IMMPIO1

module (MPI), interfaces the MFP module via a 60-pin ribbon cable that passes through a slot in the MFP module and plugs into appropriate headers on each board. The physical connection to the RS-232-C ports is accomplished through an NTMP01 Multi-Function Processor Termination Unit or NIMPO1 Multi-Function Processor Termination Module. Various handshake options are available via jumper configurations on the respective termination device.

MFP MODULE CIRCUITRY

The MFP module has all the needed circuitry to operate as a stand-alone controller. If serial ports or station links are needed, the MPI module can be added. Direct memory access (DMA) operation is supported for the IISAC01 Analog Control Station and NDCS03 Digital Control Station link. The sections that follow discuss these features. Figure 2-1 shows a block diagram of the MFP circuitry.

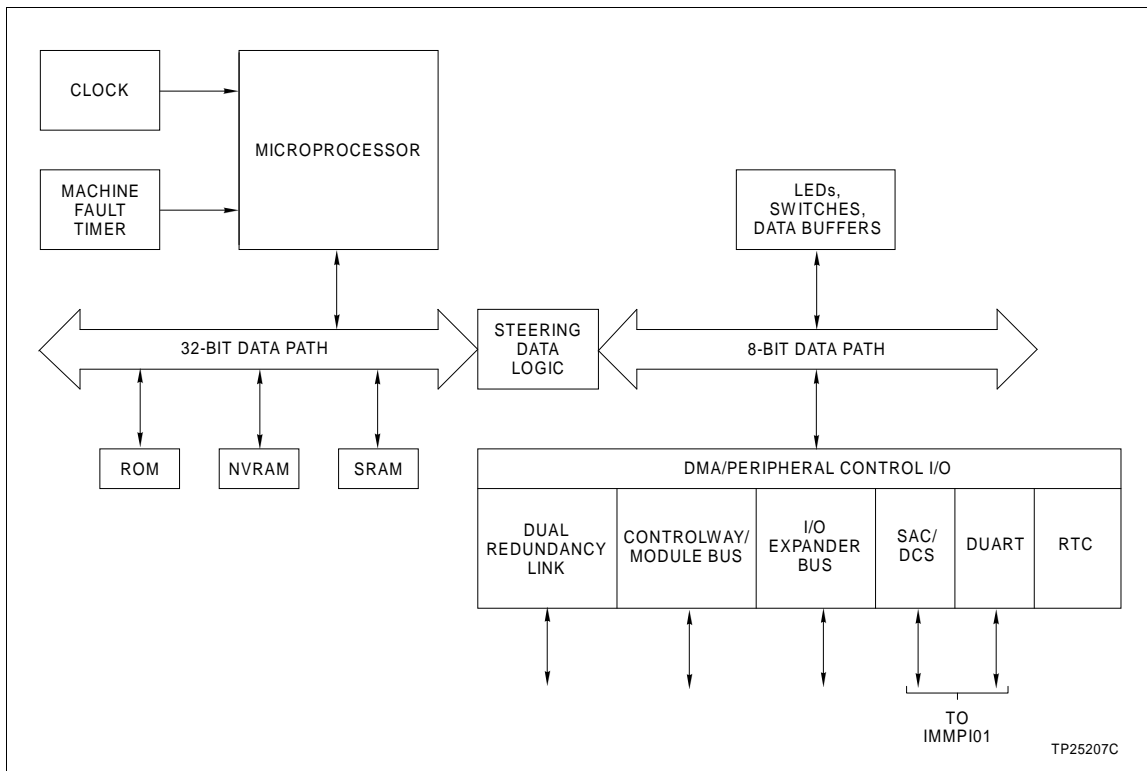

Figure 2-1. MFP Functional Block Diagram

Microprocessor

The microprocessor is responsible for module operation and control. The MFP microprocessor is a 32-bit processor that runs from a 32-megahertz clock. The microprocessor executes a synchronous access to long word memories and an asynchronous access to all byte ports. Since the microprocessor is

responsible for module operation, it communicates with all blocks of the MFP circuitry. The microprocessor operating system instructions and the function code library reside in the read only memory (ROM). The microprocessor carries out all control responsibilities as it executes the control strategy set up in its function block configuration.

The microprocessor constantly triggers the machine fault timer (MFT) circuit. If the microprocessor or software fails, the MFT circuit times out, issues a board wide reset, and the status LED turns red. This condition is a fatal module error.

Clock and Real Time Clock

The clock section provides the clock signals to drive the microprocessor and associated peripheral devices. The clock/timer section also includes a real time clock (RTC).

Memory

The IMMFP03 memory is made up of 512 kilobytes of ROM memory, two megabytes of SRAM memory (in 512-kilobyte increments using four 128-kilobyte by 32-bit memory modules) and 512 kilobytes of NVRAM memory (in 128-kilobyte by 32-bit memory modules).

The IMMFP03B memory is made up of 512 kilobytes of ROM memory, eight megabytes of SRAM memory (in two-megabyte increments using four 512-kilobyte by 32-bit memory modules) and two megabytes of NVRAM memory (in 512-kilobyte by 32-bit memory modules).

The ROM memory holds the operating system instructions for the microprocessor. The SRAM memory provides temporary storage and a copy of the system configuration. The NVRAM memory holds the system configuration (control strategy designed with function codes) and files for Batch, Basic, C, and UDF applications. NVRAM memory retains whatever information it has even when it loses power.

Direct Memory Access

The direct memory access (DMA) section enables the various communication links to do direct data transfers to and from RAM memory without processor intervention. Communication links that support direct memory access are the I/O expander bus, the dual redundancy link, the IISAC01 Analog Control Station or NDCS03 Digital Control Station serial link and Controlway. Eltag Bailey-designed chips control DMA activity.

The DMA process greatly reduces the amount of work the microprocessor needs to do when making data moves. Thus,

it greatly increases the speed of the MFP module by not overloading the microprocessor with the work associated with data moves. The microprocessor does not have to execute data moves and is free to do other tasks.

Controlway

The Controlway is a high speed communication bus. The MFP module uses this bus to communicate with other control modules within a process control unit. It provides a one-megabaud peer-to-peer communication link that can support up to 32 devices. The Controlway interface is provided by a custom integrated circuit that links the MFP module to the Controlway. It has full DMA capabilities (allowing for quicker operation), and two independent, redundant channels.

The redundant Controlway channels run through two paths on the module mounting unit backplane circuit. The MFP module transmits and receives data over both channels simultaneously. By receiving data through two channels, the MFP module can check its integrity. In this way, the Controlway minimizes the potential that a failure on a circuit board or backplane will cause loss of module communication.

The Controlway interface also allows the MFP module to run on a standard Network 90 module bus by operating in an 83.3-kilobaud mode (switch selectable). A jumper allows the MFP module to be installed in systems using early Network 90 modules that require -30 VDC. The jumper disconnects -30 VDC from pin four of connector P2 on the MFP module.

Redundancy Link

The redundancy link is a dual parallel link between a primary and backup MFP module in redundant configurations. As the primary module executes, the backup module waits in standby mode and receives a copy of block outputs over this link. If for any reason the primary module fails, the backup takes over without any process interruption.

Two parallel channels of data and control signals connect by way of an NKMP03 redundancy cable. This cable extends from connector P3 of the primary MFP module to connector P3 of the backup MFP module. Both channels have parity protection.

NOTE: Firmware revision levels must be the same in both primary and secondary MFP modules. If the firmware revision level is different and a failover occurs, the redundant MFP module may operate erratically.

I/O Expander Bus

The I/O expander bus interface is implemented using an Elsag Bailey-designed integrated circuit. The microprocessor can select one of two modes of operation: DMA or auto mode. The MFP software selects the mode of operation for the I/O expander bus. Mode selection is based on optimizing the number of bytes to be transferred. In either mode of operation, the microprocessor does not need to wait for each byte to transfer (as in previous controllers). The transfer rate is programmable in software and optimizes the data transfer rate according to the number of I/O modules attached to the MFP module.

The MFP module connects to the I/O expander bus through the backplane of the module mounting unit. It is an eight-bit parallel bus that provides the communication path for I/O data from I/O modules. The I/O expander bus supports 64 low power I/O modules (both INFI 90 and Network 90).

I/O Section

The I/O section interface allows the microprocessor to read the switches that tell it how to operate and set the module address. This section also contains latches whose outputs connect to the status and error LEDs. This section monitors redundant modules and outputs a signal to the LEDs of the primary module. Upon failover, this output de-energizes and the output of the backup module energizes as it takes over. Additionally, the I/O section monitors the stop/reset pushbutton. When the pushbutton is pressed, the I/O section insures that the module completes any I/O functions before it stops the module.

The MFP module provides only data and control signals for auxiliary I/O. Any necessary circuitry for the serial ports or station link is on the IMMPIO1 Multi-Function Processor Interface (MPI) Module. The connection between the MPI and MFP modules is buffered. During normal operation, the MFP module reads a status line from the MPI module to verify that it is installed. If it is, the MFP module transfers module data to and from the MPI module.

MPI MODULE OPERATION

The MPI module provides the MFP module with serial ports and a station link. It contains standard I/O ports (i.e., RS-485, RS-232-C) that the MFP module can use. The MPI module is an interface device that handles I/O to and from the MFP module. Control and data signals from the MFP module travel through a 60-pin ribbon cable to the MPI module.

The MPI module connects to an NTMP01 Multi-Function Processor Termination Unit. I/O signals enter or leave the MPI module through an NKTU01 or NKTU11 termination unit cable connected to an NTMP01 termination unit. Another route for the signals is through an NKTU02 or NKTU12 termination unit cable connected to an NIMP01 or NIMP02 termination module. If the serial channels are used in a redundant configuration, each MFP module must be connected to an MPI module. Redundant MPI/termination module combinations require two termination modules: the NIMP01 and NIMP02 Multi-Function Processor Termination Modules.

MPI MODULE CIRCUITRY

The MPI module contains a dual universal asynchronous receiver/transmitter (DUART) circuit, SCSI processor, clock/timer circuit, buffers and optical isolators, and power circuitry. Figure 2-2 shows a block diagram of the MPI circuitry.

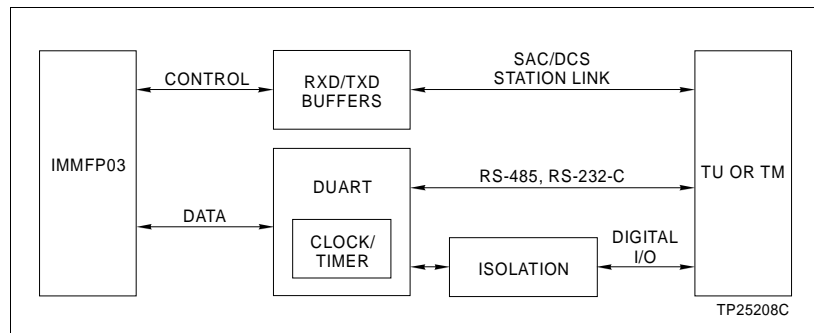

Figure 2-2. MPI Functional Block Diagram

Serial Channels (DUART)

There are two independent, general purpose serial channels on the MPI module. A DUART circuit on the MPI module supplies the serial channels with handshaking signals. There are no clock signals passed from the MFP module to the MPI module. Clock signals for the baud rate generator are derived from an on-board 7.3728-megahertz oscillator.

One use for serial ports is language support (C and Basic). Each channel can support standard baud rates up to 19.2 kilobaud. Standard D-type connectors are available on the termination unit or termination module. Jumpers, drivers and receivers on the termination unit or module convert the two serial channels (RS-485) from the MPI module into two RS-232-C ports or one RS-232-C port and one RS-485 port. These channels are optically isolated by the NTMP01, NIMP01 or NIMP02 termination device. This optical isolation eliminates the potential of damage from ground currents.

Station Link

The station link is a set of drivers and receivers on the MPI module. Station communication originates from a DUART circuit on the MFP module. This link controls the serial communication between the MFP module and the digital control stations. It has two modes of operation.

When using the link with a Network 90 NDCS03 Digital Control Station, it provides a five-kilobaud serial channel for up to eight stations. This link connects to the termination unit or module for control stations via the MPI module and NTMP01, NIMP01 or NIMP02 termination device. When interfacing the INFI 90 IISAC01 Analog Control Station, the communication rate is 40 kilobaud. The 40-kilobaud link supports 64 stations, but requires two drivers. Therefore, there are two connectors on the termination unit or module that connect to NKSE01 and NKSE11 (termination unit) cables or serial link wire (termination module). Up to 32 stations can be driven off each connection. The data transmitted over both links is identical, so the stations must have an address from zero to 63 without duplication. The 40-kilobaud communication mode has direct memory access.

SECTION 3 - INSTALLATION

INTRODUCTION

This section explains what must be done before placing the multi-function processor module into operation. Read, understand and complete the steps in the order they appear before operating the MFP module.

NOTE: This module uses connections to the module mounting unit backplane that served other functions in earlier Network 90 systems. To avoid potential module damage, evaluate your system for compatibility prior to module installation.

Earlier Network 90 systems applied -30 VDC to pins three and four of the module connector P1. This voltage is not required for INFI 90 modules. In INFI 90 systems, pin four is used for the Controlway bus.

If your system contains modules that require -30 VDC, set jumper J5 to the 30 VDC position. Doing so allows the installation of the MFP module in a module mounting unit that uses -30 VDC and limits communication to the module bus. Refer to Table 3-6 for more information about setting jumper J5.

SPECIAL HANDLING

Observe these steps when handling electronic circuitry:

NOTE: Always use Eltag Bailey's field static kit (part number 1948385□1 - consisting of two wrist straps, ground cord assembly, alligator clip and static dissipative work surface) when working with the modules. The kit grounds a technician and the static dissipative work surface to the same ground point to prevent damage to the modules by electrostatic discharge.

1. **Use Static Shielding Bag.** Keep the modules in the static shielding bag until you are ready to install them in the system. Save the bag for future use.
2. **Ground Bag Before Opening.** Before opening a bag containing an assembly with semiconductors, touch it to the equipment housing or a ground to equalize charges.
3. **Avoid Touching Circuitry.** Handle assemblies by the edges; avoid touching the circuitry.
4. **Avoid Partial Connection of Semiconductors.** Verify that all devices connected to the modules are properly grounded before using them.
5. **Ground Test Equipment.**

6. **Use an Antistatic Field Service Vacuum.** Remove dust from the module if necessary.
7. **Use a Grounded Wrist Strap.** Connect the wrist strap to the appropriate grounding plug on the power entry panel. The grounding plug must be effectively connected to the earth grounding electrode system through the AC safety ground.
8. **Do Not Use Lead Pencils to Set Dipswitches.** To avoid contamination of dipswitch contacts that can result in unnecessary circuit board malfunction, do not use a lead pencil to set a dipswitch.

UNPACKING AND INSPECTION

1. Examine the hardware immediately to verify that it has not been damaged in transit.
2. Notify the nearest Elsag Bailey sales office of any such damage.
3. File a claim for any damage with the transportation company that handled the shipment.
4. Use the original packing material and container to store the hardware.
5. Store the hardware in an environment of good air quality, free from temperature and moisture extremes.

IMMFP03 DIPSWITCHES AND JUMPERS

This section explains how to configure and install the MFP module. After installing the module, a function block configuration must be created to define the functions the module will perform.

The MFP module has four configurable dipswitches, one socket, and five jumpers. Each dipswitch has eight poles. Figure 3-1 shows the location of the socket, dipswitches and jumpers on the MFP circuit board. Dipswitch UUB0 sets the module address, bus speed and operation mode (normal/diagnostic). Dipswitch UMB1 sets module options and enables special operations. Dipswitches LMB2 and LLB3 set the SCSI bus and memory options. The HW SETUP socket defines the number of SRAM memory banks installed and selects wait states for ROM, NVRAM and SRAM memory.

Jumpers J1, J2, J4 and J5 define module functions and operation. Their setting determines if the diagnostic RS-232-C port operates as data communication equipment (DCE) or data terminal equipment (DTE). They define the density of the SRAM device installed on the module and enable the machine fault

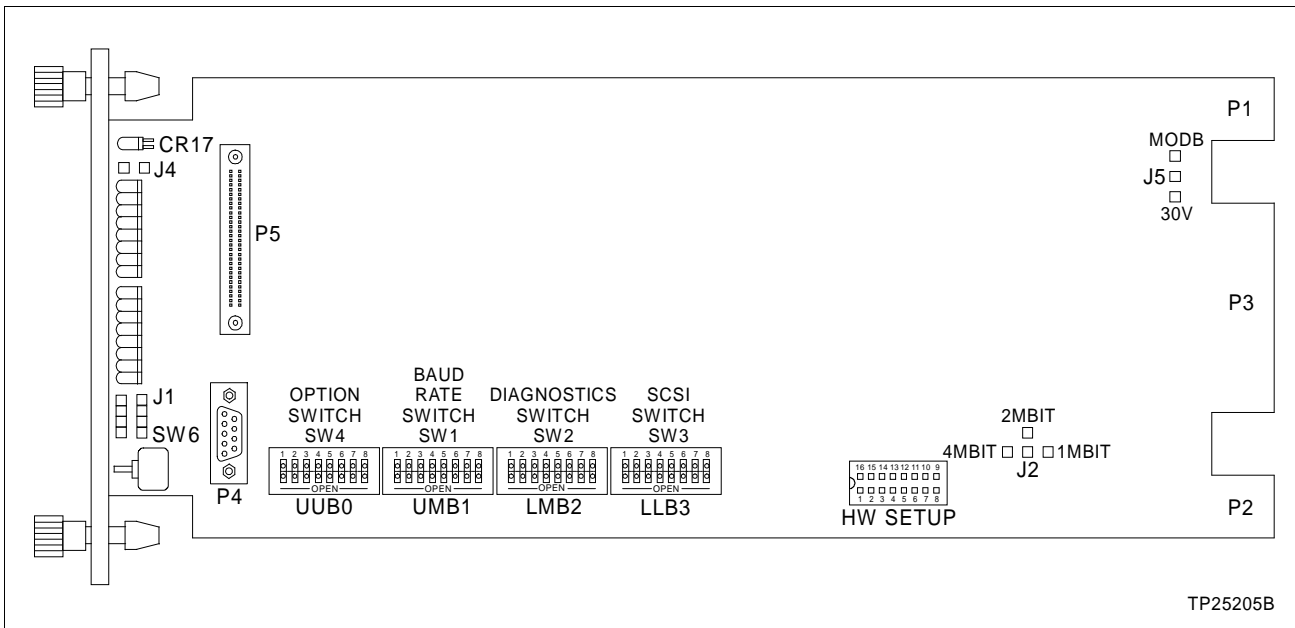

Figure 3-1. Multi-Function Processor Module Layout

timer (MFT). One jumper disengages -30 VDC from the MFP module when installing it in a module mounting unit that supplies -30 VDC to other modules.

Dipswitch poles marked not used must be set to the default settings listed in the appropriate table. The MFP module may not operate properly if these dipswitches are improperly set. Since factory settings do not reflect default settings, it is imperative that all dipswitch settings be checked before putting the module into operation.

Dipswitch UUB0 - Module Address

Dipswitch UUB0 sets the MFP Controlway or module bus address, enables module diagnostics and sets its communication rate for Controlway or module bus. The MFP module can have an address from zero through 31. Table 3-1 explains the function of dipswitch poles one through three. Table 3-2 shows examples of how to set the MFP address. Record the module address setting in the user setting portion of the table.

NOTE: Module addresses of redundant MFP modules must be identical. All modules within a process control unit must be set to communicate on either the Controlway or module bus.

Table 3-1. Dipswitch UUB0 Settings for MFP Operation

Pole	Setting	Function	User Setting
1	0	Normal run	
	1	Enable diagnostics using dipswitch UMB1	
2	0	Not used - do not change setting	
3	0	Controlway (1 Mbaud)	
	1	-30 VDC operation or module bus (83.3 kbaud) used	

NOTE: 0 = CLOSED or ON, 1 = OPEN or OFF.

Table 3-2. Dipswitch UUB0 Settings for MFP Address

Address Example	Dipswitch Pole (Binary Value)				
	4 (16)	5 (8)	6 (4)	7 (2)	8 (1)
7	0	0	1	1	1
15	0	1	1	1	1
User setting					

NOTE: 0 = CLOSED or ON, 1 = OPEN or OFF.

Dipswitch UMB1 - Module Options and Diagnostics

Dipswitch UMB1 sets module options that are available when the MFP module is in normal operation. Refer to Table 3-3 for option setting information. The options listed in Table 3-3 apply to normal MFP operation. Dipswitch UUB0 pole one must be set to zero before any option can function.

NOTE: Poles one through seven must be set the same for both modules when using redundant MFP modules.

Table 3-3. Dipswitch UMB1 Options and Diagnostics

Pole	Setting	Function	User Setting
1	0	Disable special operations.	
	1	Enable special operations. Refer to <i>Special Operations</i> .	
2	0	Disable on-line configuration.	
	1	Enable on-line configuration.	
3	0	Perform NVRAM checksum routine.	
	1	Inhibit NVRAM checksum routine. ¹	
4	0	Perform ROM checksum routine and file system check.	
	1	Inhibit ROM checksum routine and file system check.	
5	0	Enable file system check.	
	1	Disable file system check.	

Table 3-3. Dipswitch UMB1 Options and Diagnostics (continued)

Pole	Setting	Function	User Setting
6	0	Normal operation.	
	1	Compact configuration. The compact configuration function moves configured function blocks to the top of the NVRAM while moving free space to the bottom. To enable this function, OPEN the pole and insert the module into the module mounting unit. After a short time (directly proportional to the configuration size), the module will return to the mode it was in prior to being reset for the compact operation. ²	
7	0	Normal operation.	
	1	Initialize. This operation destroys (erases) the module function block configuration. Initialize NVRAM (erase configuration). Leave pole OPEN; insert module into module mounting unit. When group A LEDs 1, 2 and 4 are ON, remove the module, put the pole in the CLOSED position, and insert the module. The module is now ready to be configured. Use special operation 2 to initialize all NVRAM. NOTE: This pole must remain CLOSED for normal operation.	
8	0	Primary MFP module.	
	1	Redundant MFP module. ³	

NOTES: 0 = CLOSED or ON, 1 = OPEN or OFF.

1. This setting is used by development personnel and should never be used for normal operation. The checksum provides additional module integrity and should be used whenever the module is controlling a process.
2. Leaving this option enabled causes the configuration to be compacted every time the module is reset, thereby increasing the start-up time. This increase becomes more substantial as the size of the configuration increases. Therefore, do not leave this option enabled longer than necessary. Disabling this option stops any further compacting operations. It does not uncompact any previously compacted configuration.
3. When redundancy is used, poles 1 through 7 on the redundant MFP module are set the same as the primary MFP module. Pole 8 is set to 0 for the primary module and to 1 for the secondary module.

Special Operations

The special operations feature provides a means by which the MFP module can be configured to do a one-time special operation rather than entering its normal mode of operation. Setting dipswitch UMB1 selects the special operation. Steps 1 through 9 explain how to set the MFP module for special operations and reset it for normal operation. Table 3-4 shows the dipswitch settings and explains each special operation.

Table 3-4. Dipswitch UMB1 Special Operation Settings

Special Operation	Dipswitch Pole 1 2 3 4 5 6 7 8	Description
0	1 0 0 0 0 0 0 0	Force the MFP module into configure mode.
1	1 0 0 0 0 0 0 1	Reserved for future options. Not used at this time.
2	1 0 0 0 0 0 1 0	Initialize and format all NVRAM configuration space for Plant Loop protocol.
3	1 0 0 0 0 0 1 1	Reserved. Do not use this setting. Using this setting may cause the module to operate improperly.
4	1 0 0 0 0 1 0 0	INFI-NET protocol enable. This allows the MFP module to use the INFI-NET capabilities.

Table 3-4. Dipswitch UMB1 Special Operation Settings (continued)

Special Operation	Dipswitch Pole 1 2 3 4 5 6 7 8	Description
5	1 0 0 0 0 1 0 1	Permit segment modification (allows change to segment scheme configured with function code 82, specification S1).
6	1 0 0 0 0 1 1 0	Enable time stamping. This operation instructs the MFP module to generate time information with point data. It is applicable only to INFI-NET systems.
7	1 0 0 0 0 1 1 1	Set IMMPIO1 expected flag. Configures the IMMFP03 to expect the IMMPIO1 to be installed. The IMMFP03 will halt and display error code 1C (Hex) if the hardware does not match the configuration.

NOTE: 0 = CLOSED or ON, 1 = OPEN or OFF.

To use special operations:

1. Set dipswitch UMB1 pole 1 to position 1.
2. Set poles 2 through 8 per Table 3-4. Begin with special operation 2.
3. Insert the MFP module in its slot in the module mounting unit (refer to **INSTALLING THE MODULES**).
4. When the special operation is complete, the status LED turns red and LEDs 1 through 6 illuminate.
5. Remove the MFP module.
6. Repeat Steps 2 through 5 for any other special operation desired.

NOTE: Do special operation 2 as the first step of the module installation. If installing the MFP module in an INFI-NET environment, do special operation 4 next. For time stamping, do special operation 6 next. To reverse INFI-NET protocol or time stamping, do operation 2 again.

7. When all special operations are complete, reset pole 1 on dipswitch UMB1 to position 0.
8. Poles 2 through 8 (module options and diagnostics) should be set for the desired MFP operation per Table 3-3.
9. Insert the MFP module in its slot. It will enter its normal operating mode.

Dipswitch LMB2 - Module Options and SCSI Bus Address

Dipswitch LMB2 sets the SCSI bus options, initiator address and target address. This switch is not used at this time.

Dipswitch LLB3 - Module Options

Dipswitch LLB3 sets additional module options. This dipswitch should be set to the user settings shown in Table 3-5.

Table 3-5. Dipswitch LLB3 Option Settings

Pole	Setting	Function	User Setting
1 - 4	—	Not used	1
5	0	Disable SRAM multiple transfer	1
	1	Enable SRAM multiple transfer	
6	—	Not used	0
7	0	Disable data cache	1
	1	Enable data cache	
8	0	Disable instruction cache	1
	1	Enable instruction cache	

NOTE: 0 = CLOSED or ON, 1 = OPEN or OFF.

Jumpers J1, J2, J4 and J5

There are four jumpers on the MFP board. These jumpers are for special MFP hardware applications. They define the RS-232-C diagnostic terminal as data terminal equipment (DTE) or data communication equipment (DCE), define the type of SRAM contained on the SRAM modules, enable the machine fault timer and enable the MFP module to operate in a module mounting unit that uses -30 VDC. Refer to Table 3-6 for an explanation of the function of each jumper.

NOTE: Jumper J4 is for Elsag Bailey development personnel usage only. It is used to disable the machine fault timer circuit. If this function is disabled (jumper pins connected) and a problem develops in the MFP module, the module will not halt, which may result in configuration corruption and unpredictable module outputs.

Table 3-6. Jumpers J1, J2, J4 and J5 Settings

Jumper	Setting	Function	User Setting
J1	Vertical ¹	Sets the RS-232-C diagnostic port to operate as DCE.	
	Horizontal	Sets the RS-232-C diagnostic port to operate as DTE.	
J2 ²	4-1	Defines SRAM device density vs. no. of SRAM memory banks installed.	
J4	Open	MFT disable jumper. Must remain open for normal operation.	
J5	30V	Disconnects Controlway for operation in module mounting units that have -30 VDC (early Network 90).	
	MODB	Allows operation in module mounting units that have Controlway communication. This setting must be used if dipswitch UUB0 selects Controlway.	

NOTES:

- Used by Bailey Controls Company service personnel. The J1 setting does not affect the module during normal operation.
- Jumper J2 must be set to 4-1 for all firmware levels.

HW SETUP Socket Jumper

The HW SETUP socket defines the number of SRAM memory banks installed and selects wait states for ROM, NVRAM and SRAM memory. Refer to Table 3-7 for the jumper settings.

Table 3-7. HW SETUP Socket Jumper Settings

Position	Jumper Settings
1 to 16	Install the jumper for IMMFP03 modules containing firmware revision level E.0. Remove this jumper for firmware revision levels prior to E.0.
2 to 15	Install the jumper for IMMFP03 modules containing firmware revision level E.1 or greater. Remove this jumper for firmware revision levels prior to E.1.
3 to 14	Open.
4 to 13	
5 to 12	
6 to 11	
7 to 10	
8 to 9	

IMMPI01 JUMPER SETTINGS

The MPI module has two sets of jumpers that select RS-485 handshake signals (RTS/CTS). These signals leave the board through a cable connection to the multi-function processor termination unit or the multi-function processor termination module. Figure 3-2 shows the jumper locations on the MPI circuit board. Jumpers J1 and J2 must be set as shown in Figures 3-3 and 3-4.



Figure 3-2. IMMPIO1 Jumper Locations

Refer to NIMP01, NIMP02 and NTMP01 product instructions for information on how to select handshake signals on the termination unit or module.

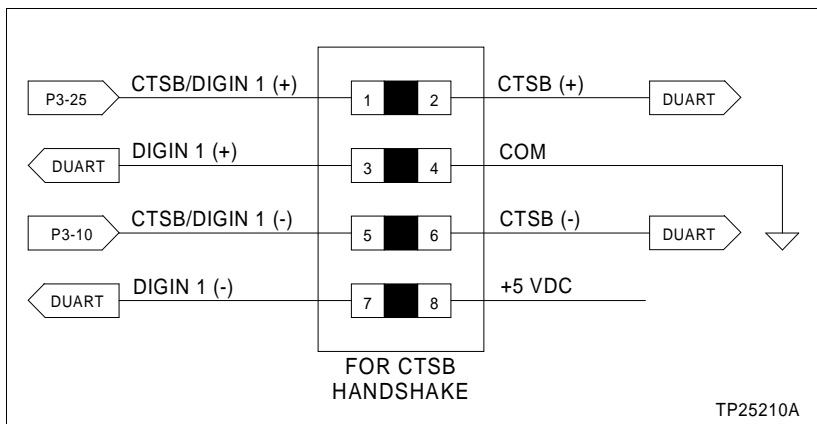

Figure 3-3. IMMPIO1 Jumper J1 Settings

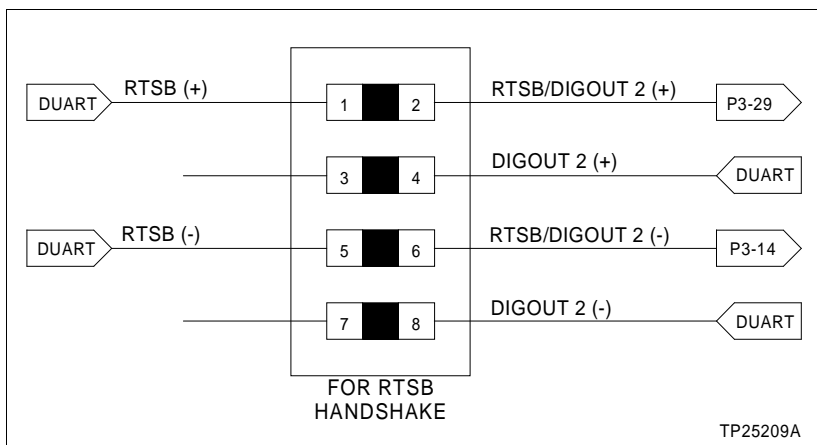

Figure 3-4. IMMPIO1 Jumper J2 Settings

PREPARING THE MODULE MOUNTING UNIT

Preparing the module mounting unit (MMU) consists of identifying the proper slots, installing the required dipshunts, and verifying the Controlway or module bus cable is installed.

Module Slot Assignments

Module placement within the module mounting unit is important when installing an MFP module with the I/O module. Installing an MPI module with the MFP module requires two adjacent slots in the MMU card cage. The MFP module must occupy the right slot (facing the front of the module mounting unit) and the MPI module must occupy the left slot.

Dipshunts

WARNING

Disconnect power before installing dipshunts on the module mounting unit backplane. Failure to do so will result in contact with cabinet areas that could cause severe or fatal shock.

AVERTISSEMENT

Interrompez l'alimentation avant d'installer des dipshunts sur le fond de panier du châssis de montage des modules. Sinon, tout contact avec cette zone entraîne des risques d'électrocution sérieuse ou fatale.

Check to see that dipshunts are in place between all module slots associated with one MFP I/O expander bus. One dipshunt goes between each module slot to maintain I/O expander bus continuity.

Controlway Cable

Install the Controlway or module bus cable in INFI 90 module mounting units as follows:

1. Attach one end of the cable (twisted 3-wire) to the bottom three tabs on the lower left of the module mounting unit backplane (facing from behind). Refer to Figure 3-5.

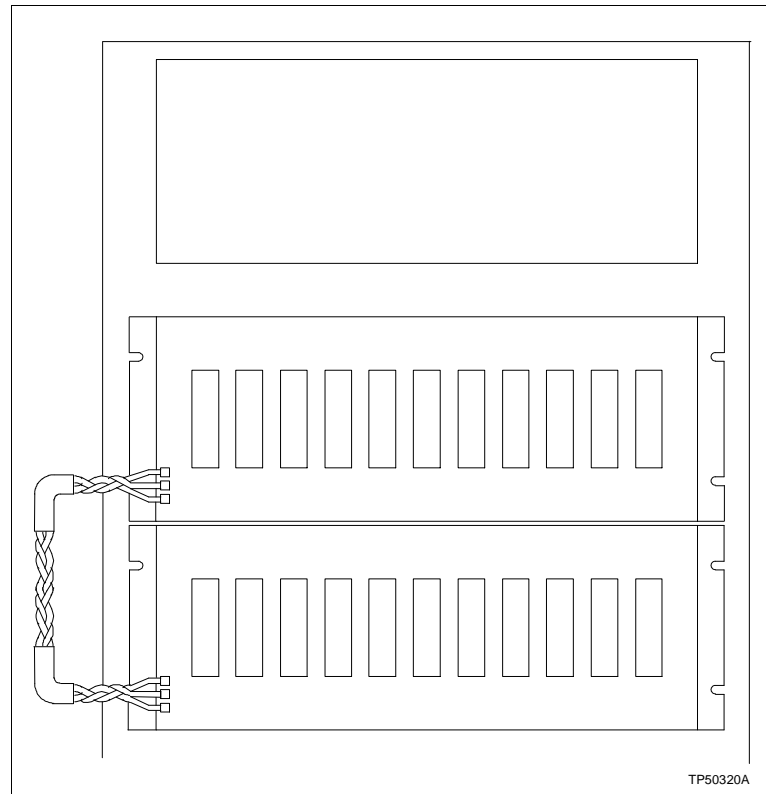

Figure 3-5. Controlway Cable Installation

2. Attach (in the same sequence) the other end of the cable to the bottom three tabs on the lower left of the next module mounting unit backplane.

NOTE: Due to high speed transaction constraints, a maximum of eight related (Controlways linked by cable) module mounting units can be installed in one cabinet. The number of interconnected module mounting units (Controlway or module bus) should be kept to a minimum to avoid crosstalk and interference. Controlways cannot be cable linked in separate cabinets.

INSTALLING THE TERMINATION UNIT OR MODULE AND FIELD WIRING

Refer to the NTMP01, NIMP01 and NIMP02 product instructions for information on how to install process wiring to these termination devices. The following steps provide general guidelines for installing termination units and modules.

NTMP01 Termination Unit Installation

1. Configure the jumpers on the termination unit. Refer to [Appendix C](#) for quick reference or to the product instruction for detailed information on jumper settings and applications.
2. Install the termination unit on the field termination panel and secure into place.
3. Connect the hooded end of the NKTU01 or NKTU11 cable to the rear of the module mounting unit slot for the MPI module.
4. Connect the other end of the cable to the P1 connector on the termination unit. For redundant modules, connect the other end of the cable to the P2 connector on the termination unit.

NIMP01 or NIMP02 Termination Module Installation

1. Configure the jumpers on the termination module. Refer to [Appendix D](#) for quick reference or to the product instruction for detailed information on jumper settings and applications.
2. Connect one end of the NKTU02 or NKTU12 cable to the rear of the termination mounting unit slot for the termination module.
3. Connect the other end of the cable to the rear of the module mounting unit for the MPI module.
4. Push the termination module into the termination mounting unit until it seats in the termination module cable connector.

INSTALLING THE MODULES

The following steps explain how to install the MFP module with an MPI module. If your application uses only an MFP module, ignore the steps involving the MPI module.

CAUTION

Never operate the MFP module with the machine fault timer circuit disabled (jumper pins connected). Unpredictable module outputs and configuration corruption may result. The unpredictable module outputs may damage control equipment connected to the MFP module.

To avoid potential module damage, evaluate your system for compatibility prior to module installation. This module uses connections to the module mounting unit backplane that served other functions in early Network 90 systems.

ATTENTION

N'utilisez jamais un module MFP sans l'usage de sa minuterie de détection de défaillance (c'est à dire avec le cavalier en place). Les sorties du module pourraient prendre des valeurs ou des états imprévisibles, et la configuration pourrait être corrompue. Le comportement imprévisible des sorties pourrait endommager le matériel de commande relié au module MFP.

Pour éviter d'endommager des modules, évaluez la compatibilité de votre système avant de les y brancher. L'usage que fait ce module de certaines connexions au fond de panier du châssis de montage diffère de l'assignation prévue par le système Network 90 original.

To determine if the module mounting unit uses -30 VDC:

1. Locate the -30 VDC faston. It is the second faston from the top when viewing the module mounting unit from the rear.
2. Check for -30 VDC with respect to system common at the -30 VDC faston.
3. If -30 VDC is present, set jumper J5 and dipswitch UUB0 to the appropriate positions.

Before installing MFP modules:

1. Check all module socket, dipswitch, and jumper settings (normal and special operation).
2. Insure that the respective module cables are attached to their proper slot in the module mounting unit backplane.
3. Modules can be installed and removed under power. When doing so, the status LED will turn red momentarily and

then turn green. If it does not, refer to the troubleshooting section.

To install MFP and MPI modules:

1. Install the high density 60-pin ribbon cable (Table 8-1) that connects the MFP module to the MPI module. Connect one end of the cable to connector P5 on the MFP module. Connect the other end of the ribbon cable to connector P6 on the MPI module.
2. Slide both modules in while guiding the top and bottom edges of both modules along the top and bottom rails of their assigned slots in the module mounting unit.
3. Push on the faceplates until the rear edge of the modules are firmly seated in the backplane connectors.

NOTE: If installing the MFP module under power, verify the status LED momentarily lights red and then remains green. If these events do not occur, refer to the troubleshooting section for corrective action.

4. Turn the two sets of latching screws $\frac{1}{2}$ -turn to lock the modules in place. The modules are locked into place when the open end of the slot on the latching screws faces the center of the faceplate.

SECTION 4 - OPERATING PROCEDURES

INTRODUCTION

The first part of this section explains what happens during start-up, the LED indicators and what they mean, and how to stop or reset the module. The last part explains the three modes of operation.

MFP MODULE START-UP

When power is applied to the IMMFP03 Multi-Function Processor Module, the module does an internal check, checks its configuration, and builds the necessary databases.

During start-up of primary modules, the front panel LEDs will go through the following sequence:

1. All front panel LEDs will illuminate red.
2. The status LED will change from red to green.
3. Group A LEDs 1 through 8 will go out.
4. Group B LEDs 1 through 6 will go out.

During start-up of secondary modules, the front panel LEDs will go through the following sequence:

1. All front panel LEDs will illuminate red.
2. The status LED will change from red to green.
3. All LEDs will go out.
4. Group B LED 7 will illuminate red and then go out.
5. Group B LED 8 will illuminate red.

If the appropriate LEDs do not illuminate, refer to [Section 5](#) for more details.

MFP MODULE LEDs

There are 17 LEDs visible through the faceplate window. Eight group A and eight group B LEDs relate to processor status, and one is the module status LED (Fig. [4-1](#)).

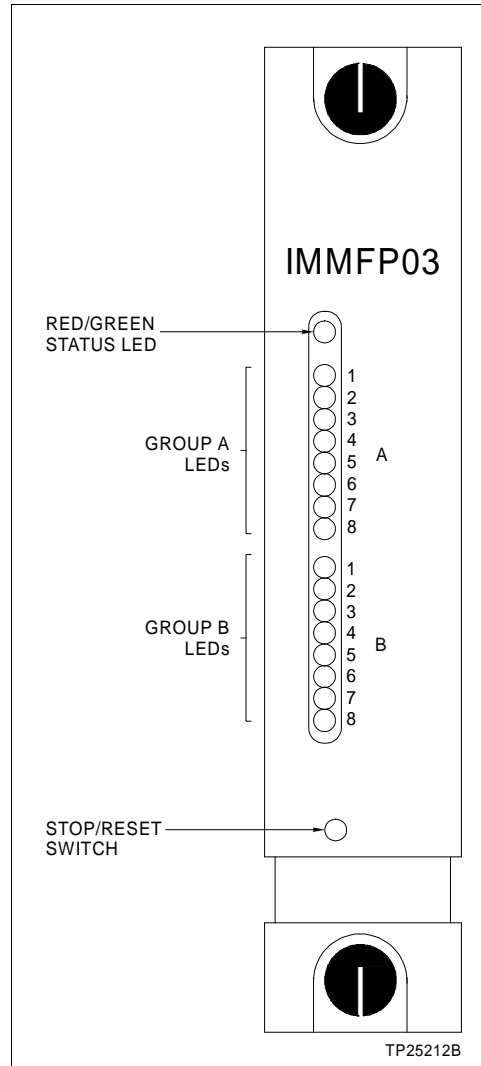

Figure 4-1. MFP Front Panel

Front Panel LEDs

Group A LEDs display the pass and fail counts when the module is in diagnostic mode. Group B LEDs display codes if a module error occurs during normal operation. Additionally, in redundant configurations, they show which module is the primary and which is the secondary. Group B LEDs seven and eight are on if the module is primary; group B LED eight is on if the module is secondary. If an error occurs, the MFP status LED turns red and the group B LEDs light up to display the error code (Table 5-1). Note that both groups of LEDs one through eight are on when the system is first coming up. This is normal. It means that the module is not yet on-line.

Red/Green Status LED

The status LED is a red/green LED. It shows MFP operating condition. There are four possible states.

Off	No power to the module or the module is powered and jumper J4 is installed (machine fault timer disabled). The machine fault timer circuit must be enabled. The status LED momentarily goes off when the microprocessor initializes on start-up.
Solid Green	The module is in execute mode.
Flashing Green	The module is in execute mode but there is an NVRAM checksum error, or the module is in the configure or error mode.
Solid Red	The MFP diagnostics have detected a hardware failure, configuration problem, etc., and stopped the module. Additionally, the group B LEDs will illuminate in a certain sequence to display the error code.

MFP MODULE STOP/RESET SWITCH**NOTES:**

1. Do not remove an operational MFP module under power unless the stop/reset switch has been depressed once and the module has halted (status LED is red and group B LEDs one through six are on). This procedure must be followed when removing a module from a redundant configuration. An operational module must halt operation before control passes to the secondary module.
2. Firmware revision levels must be the same in both primary and secondary MFP modules. If the firmware revision levels are different and a failover occurs, the secondary MFP module may operate erratically.

The stop/reset switch is a two-hit switch. It stops the module in an orderly manner, preventing glitches on the bus. The switch is accessible through the opening on the faceplate (Fig. 4-1). Since the opening is small, pressing the switch requires a thin round object. Pressing the switch once stops MFP operation. Always stop the MFP module before removing it from the module mounting unit. Stopping the module in this way causes it to:

- Save and lock the MFP configuration.
- Complete any nonvolatile memory write operations in progress.
- Deactivate all communication links.
- Transfer control from the primary module to the secondary module in redundant configurations.
- Change the status LED color to red.

Once the module is stopped, pressing the switch again resets the module. Use the reset mode to:

- Reset the default values to the power up values.
- Recover from a module time-out or operator-initiated stop.

NOTE: Pressing and holding the stop/reset switch provides no additional functionality over pressing and releasing the switch. It will only stop the module. To stop the module, press and release the stop/reset switch. To reset the module, press the stop/reset switch a second time. If the module halts due to an error (causing the status LED to turn red), a single push of the stop/reset switch resets the module.

MFP MODULE MODES OF OPERATION

The MFP module has three operating modes: configure, execute and error.

Configure Mode

Use the configure mode to enter control strategies. The MFP module receives configuration commands over Controlway or module bus and changes the data in the NVRAM memory.

NOTE: The process of configuring the module requires information from at least two documents. The **Function Code Application Manual** contains all of the information needed to design a control strategy. The instruction manual for the particular configuration tool being used (e.g., CAD/TXT EWS) explains the steps required to download control strategies into the MFP memory.

Execute Mode

The execute mode is the normal mode of operation. In this mode, the MFP module communicates with I/O modules and other control modules. The MFP module also processes exception reports and configuration and control messages. It executes control configurations, reads inputs and updates outputs.

Error Mode

The MFP module goes into error mode whenever the built-in system diagnostics detect a hardware or configuration error. If a hardware error is detected, the module halts and displays the error code using group B LEDs one through eight. If an NVRAM error is detected, the status LED flashes, but the module continues to operate. This is possible because a copy of the configuration is held in RAM and executed on from there. The next time the module is reset it will not start up, but will fail with an NVRAM error.

MPI MODULE OPERATION

Upon proper installation, the IMMPIO1 Multi-Function Processor Interface Module (MPI) is ready for operation. The MPI module waits for the MFP module to give it a command to execute; it does nothing on its own.

MPI MODULE LED

There is one yellow LED on the faceplate of the MPI module (Fig. 4-2). It has two possible states.

- Solid Yellow** MPI module is disabled by the MFP module.
- Off** MPI module is enabled by the MFP module.

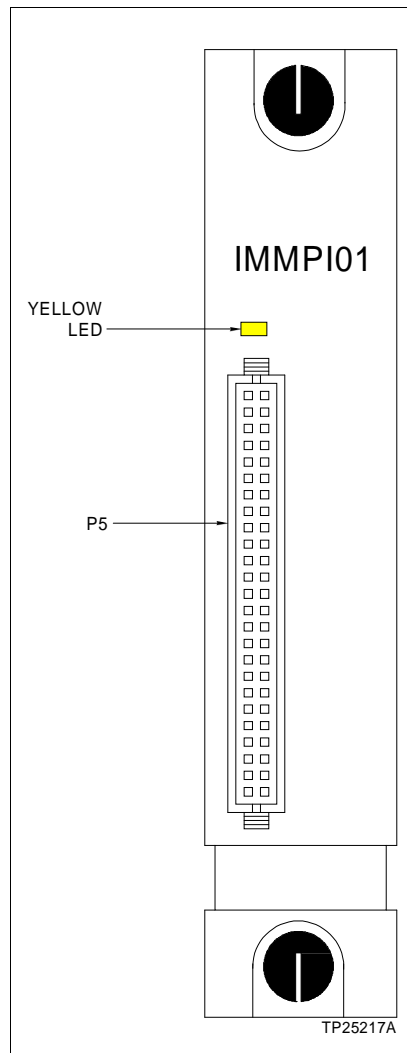

Figure 4-2. MPI Front Panel

SECTION 5 - TROUBLESHOOTING

INTRODUCTION

This section contains IMMFP03 Multi-Function Processor (MFP) Module troubleshooting information. Included is information on module error codes, troubleshooting flowcharts, diagnostic routines available, and the module status summary. Refer to Table 5-1 for MFP error codes, their meanings and appropriate corrective action. Table 5-2 shows all other LED states. The flowcharts in Figures 5-1 and 5-2 provide a quick look at hardware associated problems that may occur during module installation and start-up.

Diagnostic tests help determine if there is a problem with module components or circuitry. They are useful for testing the module when the system is down or there is some other means of controlling the process. For example, use the backup module (if redundant modules are installed) to control the process while testing the primary module. The module status summary is a 16-byte module status record that provides summary flags for error conditions, module type, and firmware revision level.

Table 5-1. IMMFP03 Error Codes

Code	LED	Condition	Corrective Action
	8 7 6 5 4 3 2 1		
01	0 0 0 0 0 0 0 1	NVRAM checksum error	Initialize NVRAM. If error recurs call Bailey field service.
02	0 0 0 0 0 0 1 0	Analog input calibration	Check I/O module error.
03	0 0 0 0 0 0 1 1	I/O module status bad	Check module status and I/O modules.
05	0 0 0 0 0 1 0 1	Configuration error (undefined block)	Check module status undefined block (modules referenced).
06	0 0 0 0 0 1 1 0	Configuration error (data type mismatch)	Check module status (data type) modules.
08	0 0 0 0 1 0 0 0	Trip block activated	Check module status.
0B	0 0 0 0 1 0 1 1	NVRAM initialized	Confirm that NVRAM is initialized; no action is required.
0C	0 0 0 0 1 1 0 0	NVRAM opened for write	Initialize NVRAM. If error recurs, call Bailey field service.
0D	0 0 0 0 1 1 0 1	Intermodule link error	Check cable between primary and secondary MFP modules.
0E	0 0 0 0 1 1 1 0	Redundancy IDs the same	Put position 8 of UMB1 in the opposite position of the primary module UMB1 position 8.
0F	0 0 0 0 1 1 1 1	Primary failed, backup cannot take over, configuration not current	Check configuration. Correct any faulty values. Execute the configuration.

Table 5-1. IMMFP03 Error Codes (continued)

Code	LED 8 7 6 5 4 3 2 1	Condition	Corrective Action
10	0 0 0 1 0 0 0 0	Primary failed, backup cannot take over, data not check pointed	Check configuration. Correct any faulty values. Execute the configuration.
11	0 0 0 1 0 0 0 1	Error during write to nonvolatile memory	
12	0 0 0 1 0 0 1 0	Backup and primary module addresses are different	Set addresses the same.
13	0 0 0 1 0 0 1 1	ROM checksum error	Contact Bailey field service.
14	0 0 0 1 0 1 0 0	MFP set for INFI-NET/ Superloop but in a Plant Loop environment	Reformat MFP module.
15	0 0 0 1 0 1 0 1	RS-232-C carrier detect line error	Check jumpers and cables. If error recurs, replace MFP module.
16	0 0 0 1 0 1 1 0	Type code mismatch between primary and backup	Reformat MFP module.
17	0 0 0 1 0 1 1 1	Duplicate Controlway address detected	Set address to unique value in PCU.
1C	0 0 0 1 1 1 0 0	IMMPIO1 fault, hardware does not match configuration	Do special operation 7. Refer to Table 3-4.
20	0 0 1 0 0 0 0 0	C program format error	Repeat configuration download.
21	0 0 1 0 0 0 0 1	File system error	Check file directory, replace bad file.
22	0 0 1 0 0 0 1 0	Invoke C error	Check C program and invoke C blocks, correct and rerun.
23	0 0 1 0 0 0 1 1	User write violation	Check C program, correct and rerun.
24	0 0 1 0 0 1 0 0	C program stack overflow	
28	0 0 1 0 1 0 0 0	User defined function (UDF) block number reference invalid	Check configuration. Fix block configuration. Fix block reference.
29	0 0 1 0 1 0 0 1	UDF function block cannot read program	Check configuration. Fix UDF block file.
2A	0 0 1 0 1 0 1 0	Not enough memory for UDF	Revise configuration.
2B	0 0 1 0 1 0 1 1	Missing UDF declaration	Add function code 190 to configuration.
2C	0 0 1 0 1 1 0 0	Wrong UDF type	Put correct UDF type in configuration.
2D	0 0 1 0 1 1 0 1	Missing UDF auxiliary	Put function code 198 in block configuration.
2E	0 0 1 0 1 1 1 0	UDF compiler and firmware incompatible	Check firmware revision level. Verify that it supports UDF.
2F	0 0 1 0 1 1 1 1	Basic program error	Check Basic program, correct and rerun.
30	0 0 1 1 0 0 0 0	Primary active during failover attempt	Replace primary and/or backup to determine faulty module.
31	0 0 1 1 0 0 0 1	Memory or CPU fault	Replace MFP module. If error recurs, call Bailey field service.
32	0 0 1 1 0 0 1 0	Address or bus error	Reset MFP module. If error recurs, replace MFP module.
33	0 0 1 1 0 0 1 1	Illegal instruction	
34	0 0 1 1 0 1 0 0	Internal error - trace/privilege violation	

Table 5-1. IMMFP03 Error Codes (continued)

Code	LED 8 7 6 5 4 3 2 1	Condition	Corrective Action
35	0 0 1 1 0 1 0 1	Internal error - spurious/ unassigned exception	Reset MFP module. If error recurs, replace MFP module.
36	0 0 1 1 0 1 1 0	Internal error - divide by 0 or check instruction	
37	0 0 1 1 0 1 1 1	Internal error - undefined trap	Restart MFP module. If error recurs, replace MFP module.
38	0 0 1 1 1 0 0 0	Board level hardware error	Contact Bailey field service.
3F	0 0 1 1 1 1 1 1	Normal stop	None.
40	0 1 0 0 0 0 0 0	Backup - cold takeover ready	
80	1 0 0 0 0 0 0 0	Backup - hot takeover ready	
C0	1 1 0 0 0 0 0 0	Primary - operating	
XX ¹	—	Unknown	Contact Bailey field service.

NOTE:

1. This symbol represents any LED combination not specifically addressed in this table.

Table 5-2. Other MFP Module Conditions

LED	Condition	Corrective Action
Status	Off	Check power.
		Check module seating.
		Check jumper J4. Remove if installed.
		If power and seating are okay, remove the module and replace with identically configured module.
	Red	Press reset button. If LED remains red, remove the module and replace with identically configured module.
	Green	None - normal.
	Orange	Remove jumper J4.
Group B 7/8	Off	Check power.
		Check module seating.
		If power and seating are okay, remove the module and replace with identically configured module.
Red	None - indicates primary module.	
Group B 8	Off	Check power.
		Check module seating.
		If power and seating are okay, remove the module and replace with identically configured module.
	Red	None - indicates backup module in redundant configuration.

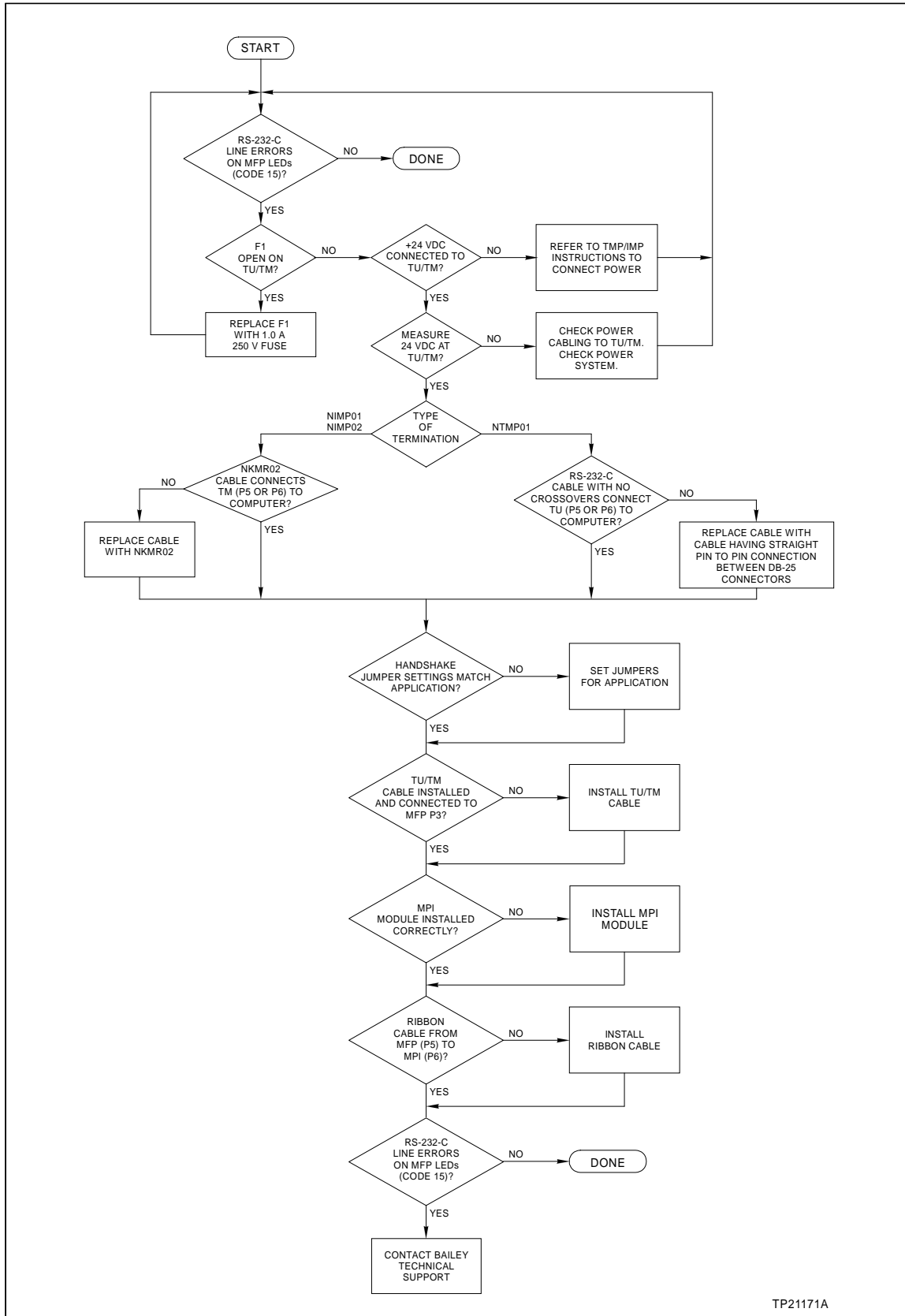

TP21171A

Figure 5-1. MFP Troubleshooting Flowchart (Serial Port)

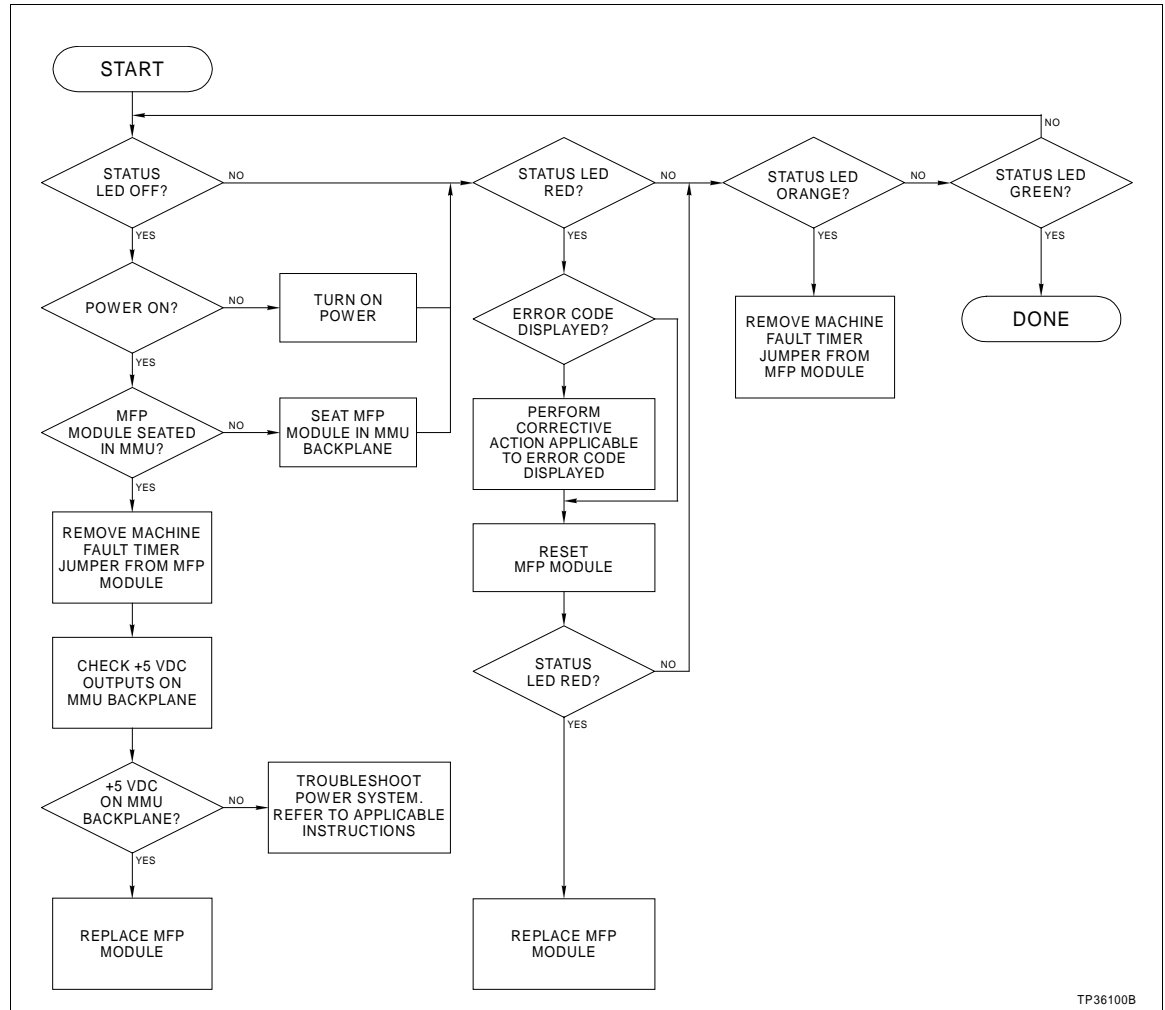

Figure 5-2. MFP Troubleshooting Flowchart (Status LED)

CARD EDGE CONNECTORS

Each module (MFP and MPI) has three card edge connectors that provide them with power and I/O. Tables 5-3 through 5-8 list the MFP and MPI card edge connector pin assignments.

Table 5-3. MFP Connector P1 Pin Assignments

Pin	Signal	Pin	Signal
1	+5 VDC	2	+5 VDC
3 ¹	-30 VDC/power supply status	4	Controlway B
5	Common	6	Common
7	+15 VDC	8	-15 VDC
9	Power fail interrupt	10	Unused
11	Controlway A/module bus	12	Unused

NOTE:

1. This pin will carry -30 VDC when the MFP module is used in -30 VDC Network 90 systems. This pin will carry the power supply status signal when the module is used in newer Network 90 and INFI 90 systems.

Table 5-4. MFP Connector P2 Pin Assignments

Pin	Signal	Pin	Signal
1	Data bit 1	2	Data bit 0
3	Data bit 3	4	Data bit 2
5	Data bit 5	6	Data bit 4
7	Data bit 7	8	Data bit 6
9	Bus clock - BCLK	10	Sync
11	Unused	12	Unused

NOTE: All data bits are true low.

Table 5-5. MFP Connector P3 Pin Assignments

Pin	Signal	Pin	Signal
1	Red1 parity	16	Ground
2	Red1 data7	17	Red1 data6
3	Red1 data5	18	Red1 data4
4	Red1 data3	19	Red1 data2
5	Red1 data1	20	Red1 data0
6	Ground	21	Ground
7	Red1 BCLK	22	Red2 BCLK
8	Ground	23	Ground
9	Red1 busy	24	Red2 busy
10	Ground	25	Ground
11	Red2 data7	26	Red2 data6
12	Red2 data5	27	Red2 data4
13	Red2 data3	28	Red2 data2
14	Red2 data1	29	Red2 data0
15	Ground	30	Red2 parity

Table 5-6. MFP Connector P4 Pin Assignments

Pin	Signal	
	DTE	DCE
2	Receive data	Transmit data
3	Transmit data	Receive data
5	Ground	Ground
7	Request to send	Clear to send
8	Clear to send	Request to send

*Table 5-7. MPI Connector
P1 Pin Assignments*

Pin	Signal
1, 2	+5 VDC
3, 4	Unused
5, 6	Common
7 - 12	Unused

Table 5-8. MPI Connector P3 Pin Assignments

Pin	Signal	Pin	Signal
1	SAC/DCS link A (-)	16	SAC/DCS link A (+)
2	SAC/DCS link B (-)	17	SAC/DCS link B (+)
3 - 6	Unused	18 - 21	NC
7	Receive data A (-)	22	Receive data A (+)
8	Receive data B (-)	23	Receive data B (+)
9	Clear to send A (-)	24	Clear to send A (+)
10	Clear to send B (-)	25	Clear to send B (+)
11	Transmit data A (-)	26	Transmit data A (+)
12	Transmit data B (-)	27	Transmit data B (+)
13	Request to send A (-)	28	Request to send A (+)
14	Request to send B (-)	29	Request to send B (+)
15	Digital output 1 (+)	30	Digital output 1 (-)

DIAGNOSTICS

The MFP firmware contains diagnostic routines that can be invoked during module power up. These routines verify the proper operation of the module components and circuitry. Putting the MFP module in the diagnostic mode allows the module to perform a variety of diagnostic tests but suspends normal operation. Therefore, use it during installation to check module integrity, when the system is down, or transfer control to a backup MFP module. The information that follows describes how to use the diagnostic routines and gives a brief description of each test routine.

Overview

Select the required diagnostic routine using the MFP dipswitches. Diagnostic test results display on the MFP front panel LEDs. Both group and individual tests can be executed. The typical procedure is to select a diagnostic to execute, set the module dipswitches accordingly, reset the module, and observe the results on the faceplate LEDs. If the halt on error feature is disabled, the selected test runs repeatedly until the module is reset and another test is selected. If halt on error feature is enabled, the test stops and the LEDs display the failure.

An additional module is required for I/O expander bus communication tests. To test:

1. Set the dipswitches on the IMDS004 (DSO) module and the MFP module to the settings in Table 5-9.
2. Insert the DSO module in the same module mounting unit (MMU) as the MFP module.

3. There must be continuity between the DSO and MFP modules on the I/O expander bus (i.e., I/O expander bus dipshunts inserted with straps intact between the DSO and MFP modules). The modules do not need to be in adjacent slots.

An additional NTMP01, NIMP01 or NIMP02 termination device is required for redundancy link and SAC/DCS link tests.

Table 5-9. DSO and MFP Setup for I/O Expander Bus Test

Module	Address Dipswitch	Pole							
		1	2	3	4	5	6	7	8
IMDSO04	S1	0	0	0	0	1	1	1	1
IMMFP03	LMB2	0	0	0	0	1	1	1	1

NOTE: 0 = CLOSED or ON, 1 = OPEN or OFF.

Dipswitch Selection

Pole one of dipswitch UUB0 must be set to one (off position) to put the module into the diagnostic mode. The remaining poles are used to select module address and Controlway or module bus communication. They should remain in their normal operating position. Dipswitch UMB1 enables or disables the special operations feature and selects the diagnostic test. Figure 5-3 shows the definition of the dipswitch poles.

On dipswitch UMB1, poles three through eight select the diagnostic test. Pole eight is the least significant bit (binary weight one); pole three is the most significant bit (binary weight 32).

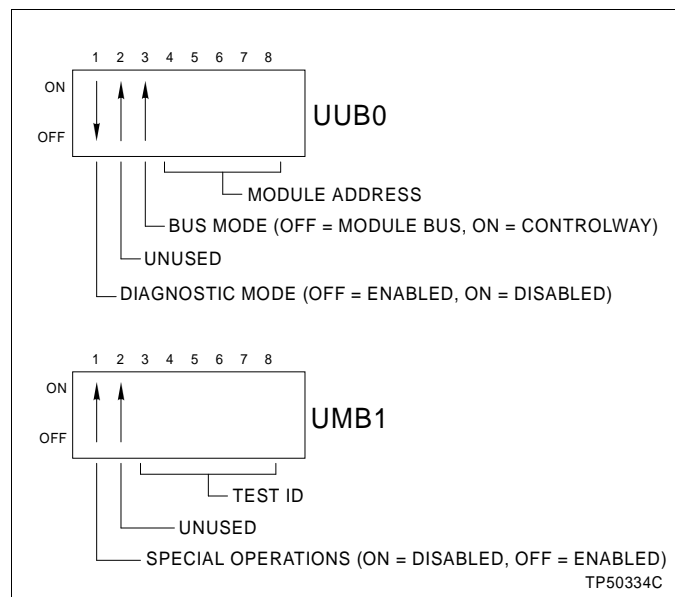

Figure 5-3. Diagnostic Dipswitch Positions

Refer to Table 5-10 for test ID values. Pole one selects a special operations feature. When enabled, the MFP module will halt test execution whenever the selected test detects an error. The number of the failing test is displayed on the group B LEDs (Fig. 5-4). The group A LEDs display the pass/fail count. Refer to Table 5-10 for a description of each diagnostic test.

Table 5-10. Diagnostic Tests

Test Name	Test-ID	Description
Switches and LEDs	00	Byte value of all dipswitches are exclusive ORed together. Results are displayed on LEDs. Status LED is OFF for even or ON for odd total.
CPU	01	Verifies CPU instruction set is operational.
ROM	02	Calculates checksum of ROM and compares it to value stored in ROM during programming.
RAM	03	Performs walking 1 test. Clears, verifies, sets and verifies all RAM. Test includes byte, word and long word accesses.
NVRAM	04	Verifies read and write function of NVRAM.
Timer	05	Initializes DUART timer for 1-msec interrupts and then waits for it to time-out.
Real time clock	06	Verifies real time clock is functioning.
I/O expander bus stall	07	Sets a latch enabling a level 7 interrupt to occur.
Module bus/Controlway	08	Sends series of bytes to Controlway verifying timing and transfer status.
Dispatcher IRQ2	09	Issues software dispatcher request and waits for interrupt to occur.
RS-232 DUART 0 ¹	0A	Tests (in local loopback mode) both serial channels of DUART circuitry.
DUART 1	0B	Tests (in local loopback mode) both serial channels of DUART circuitry that supports stations and redundancy links.
Immediate INT	0C	Sets and resets all interrupt levels verifying proper operation.
Unused	0D-0F	—
Group test 1 ¹	10	Executes tests 01 through 0F.
I/O expander bus test ²	11	MFP module performs status read and verifies the IMDSO04 (address 15) responds over I/O expander bus. IMDSO04 LEDs count successful tests.
Unused	12	—
SAC/DCS link	13/23	Two MFP modules transmit and receive messages from each other over TU/TM redundancy link. Primary module test is 13, backup module test is 23.
Redundancy link	14/24	Two MFP modules transmit and receive messages from each other over TU/TM or NKMP03 redundancy link. Primary module test is 14, backup module test is 24.
SCSI	15	Verifies SCSI processor integrity.
Unused	16-1F	—
Group test 2	20	Executes tests 00 through 1F.
Null test	21	Always passes.
SAC and redundancy link backup	22	Displays running count of bytes received by secondary MFP module when primary MFP module is executing test 20.

Table 5-10. Diagnostic Tests (continued)

Test Name	Test-ID	Description
I/O expander bus assassin circuit halt test ³	25	Arms assassin circuit and allows I/O expander bus clock to stall.
NVRAM retention - data storage ³	26	Stores known data pattern in NVRAM.
NVRAM retention - data check	27	Verifies NVRAM holds data pattern stored in test 26.
Unused	28	—
Stop pushbutton ³	29	Verifies proper pushbutton operation. A level 1 interrupt should occur when the pushbutton is pressed once.
MMU	2A	Verifies proper operation of the on-board memory management unit.

NOTES:

1. Must have the IMMPIO1 I/O module installed to pass.
2. Requires the IMDSO04 module (Table 5-9).
3. These tests are not continuous.

LED Display

The front panel LEDs (Fig. 5-4) are used during diagnostic mode operation to display test results.

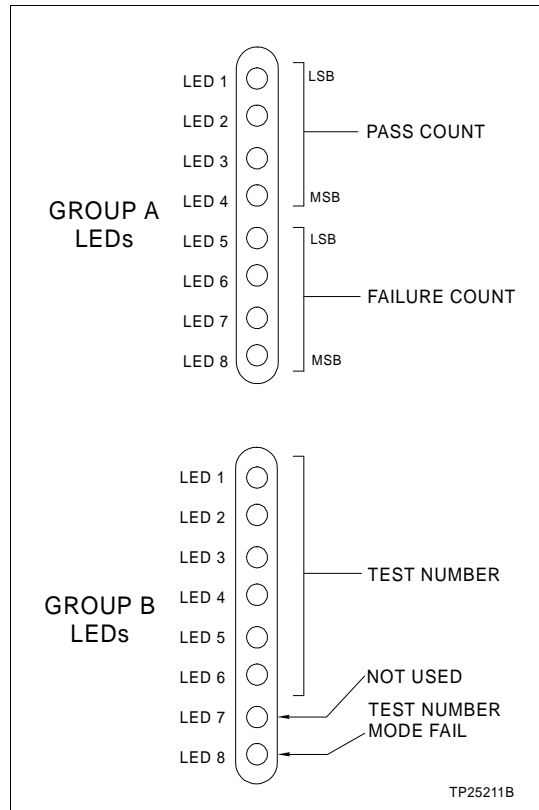

Figure 5-4. LEDs - Pass/Fail

On module reset, all front panel LEDs turn on. Next, the MFP module reads the dipswitches, executes the selected test and displays the result on the group A and group B LEDs. Group B LEDs display the test number on LEDs one through six. If LED eight is on, the test failed. The display is latched on for 1/4-second for viewing ease, then the LEDs blank out for about 1/8-second, and the test is repeated. Group A LEDs display a running tally of successes and failures. LEDs one through four tally the passes; LEDs five through eight tally the failures.

If a test fails with the special operations feature selected (dipswitch UMB1, pole one ON), the status LED turns red. The test number that failed is displayed on the group B LEDs.

For group tests (10, 20), each test is run in numerical order. On a failure, group B LED eight flashes and LEDs one through six display the test number that failed. When all tests in the group are done, the error count is incremented and displayed on the group A LEDs.

IMMFP03 MODULE STATUS SUMMARY

The multi-function processor module has a 16-byte module status record that provides summary flags for error conditions, module type, and firmware revision level. Table 5-11 shows the fields of the IMMFP03 status report. Table 5-12 lists the definition of each field within the module status report.

Refer to the operator interface station, management command system console, or engineering work station product instruction for an explanation of how to access the module status report.

Table 5-11. IMMFP03 Status Report

Byte	Bit							
	7	6	5	4	3	2	1	0
1	ES	MODE		MODULE TYPE				
2	FTX	BAC	RIO	LIO	CFG	NVF	NVI	DSS
3	Bytes 3-5 combine to define other errors (Table 5-12)							
4								
5								
6	Extended module type = 24							
7	A	B	R1	R2	P			
8-13	Unused							
14	Nomenclature (decimal digit)							
15	Firmware revision level (ASCII letter)							
16	Firmware revision level (ASCII digit)							

Table 5-12. Field Descriptions of the MFP Status Report¹

Byte	Field	Value	Description
1	ES	—	Error summary (0 = good, 1 = errors)
	MODE	—	Module mode (00 = configuration, 01 = error, 11 = execute)
	MODULE TYPE	—	Module type code (15 = enhanced status)
2	FTX	—	First time in execute (0 = no, 1 = yes)
	BAC	—	Backup MFP status (0 = good, 1 = bad)
	RIO	—	Summary remote I/O status (0 = good, 1 = bad)
	LIO	—	Summary local I/O status (0 = good, 1 = bad)
	CFG	—	On-line configuration changes being made (0 = no, 1 = yes)
	NVF	—	NVRAM checksum error (0 = good, 1 = bad)
	NVI	—	NVRAM default configuration (0 = no, 1 = yes)
	DSS	—	Digital station status (0 = good, 1 = bad)
3 - 5	—	3 4 5	
	—	01 01 — 01 02 — 01 03 — 01 FA — 01 FF —	NVRAM error: Checksum failure Bad data Reset during SP write Reset during write
	—	02 00 04 02 00 05	Analog input reference error: 1 V reference 5 V reference
	—	03 <X> ² <Y> ²	Missing I/O module: XY = block no.
	—	05 <X> ² <Y> ²	Configuration error - undefined input: X = block no. making reference Y = block no. being referenced
	—	06 <X> ² <Y> ²	Configuration error - data type match: X = block no. making reference Y = block no. being referenced
	—	08 <X> ² <Y> ²	Trip block activated: X = block no. of trip block Y = block no. making reference
	—	0F — —	Primary MFP module has failed and the redundant MFP configuration is not current.
	—	10 — —	Primary MFP module has failed and the SRAM data in the redundant MFP module is not current.
	6	—	—
7	A	—	Controlway bus A (80 = failure)
	B	—	Controlway bus B (40 = failure)
	R1	—	Redundancy link channel 1 (20 = failure)
	R2	—	Redundancy link channel 2 (10 = failure)
	P	—	Peripheral failure (1 = yes)
14	—	—	Nomenclature: 01 = IMMFP01, 02 = IMMFP02, 03 = IMMFP03
15	—	—	Revision letter, ASCII letter
16	—	—	Revision number, ASCII digit

NOTES:

- All fields listed in this table are expressed in hexadecimal format unless otherwise specified.
- All block numbers in BCD.

SECTION 6 - MAINTENANCE

INTRODUCTION

WARNING

Wear eye protection whenever working with cleaning solvents. When removing solvents from printed circuit boards using compressed air, injury to the eyes could result from splashing solvent as it is removed from the printed circuit board.

AVERTISSEMENT

Des lunettes de protection devraient être portées lors de travail avec des solvants nettoyants. Lorsqu'on enlève les solvants des circuits imprimés à l'aide d'air comprimé, les éclaboussures de solvant pourraient causer des blessures aux yeux.

The reliability of any stand-alone product or control system is affected by the maintenance of the equipment. Elsag Bailey recommends that all equipment users practice a preventive maintenance program that will keep the equipment operating at an optimum level.

This section presents procedures that can be performed on-site. These preventive maintenance procedures should be used as guidelines to assist you in establishing good preventive maintenance practices. Select the minimum steps required to meet the cleaning needs of your system.

Personnel performing preventive maintenance should meet the following qualifications:

- Should be qualified electrical technicians or engineers that know the proper use of test equipment.
- Should be familiar with the IMMFP03 Multi-Function Processor (MFP) Module, have experience working with process control systems, and know what precautions to take when working on live AC systems.

PREVENTIVE MAINTENANCE SCHEDULE

Table 6-1 is the preventive maintenance schedule for the MFP module. The table lists the preventive maintenance tasks in groups according to their specified maintenance interval. Some tasks in Table 6-1 are self-explanatory. Instructions for tasks that require further explanation are covered under **PREVENTIVE MAINTENANCE PROCEDURES**.

NOTE: The preventive maintenance schedule is for general purposes only. Your application may require special attention.

Table 6-1. Preventive Maintenance Schedule

Task	Frequency
Check cabinet air filters. Clean or replace them as necessary. Check the air filter more frequently in excessively dirty environments.	3 months
Check cabinet and MFP module for dust. Clean as necessary using an antistatic vacuum.	
Check all MFP signal, power and ground connections within the cabinet. Verify that they are secure. See procedure.	
Check MFP circuit boards, giving special attention to power contacts and edge connectors. Clean as necessary. See procedure.	12 months
Complete all tasks in this table.	Shutdown

EQUIPMENT AND TOOLS REQUIRED

Listed are the tools and equipment required for maintenance:

- Antistatic vacuum.
- Clean, lint free cloth.
- Compressed air.
- Eberhard Faber (400A) pink pearl eraser or equivalent.
- Fiberglass or nylon burnishing brush.
- Foam tipped swab.
- Bladed screwdriver suitable for terminal blocks.
- Isopropyl alcohol (99.5 percent electronic grade).
- Natural bristle brush.

PREVENTIVE MAINTENANCE PROCEDURES

Tasks from Table 6-1 that require further explanation include:

- Cleaning printed circuit boards.
- Checking signal, power and ground connections.

Printed Circuit Board Cleaning

There are several circuit board cleaning procedures in this section. These procedures cover circuit board cleaning and washing, cleaning edge connectors and circuit board laminate between edge connectors. Use the procedures that meet the needs of each circuit board. Remove all dust, dirt, oil, corrosion or any other contaminant from the circuit board.

Do all cleaning and handling of the printed circuit boards at static safe work stations. Observe the steps listed in **SPECIAL HANDLING** in Section 3 when handling printed circuit boards.

GENERAL CLEANING AND WASHING

If the printed circuit board needs minor cleaning, remove dust and residue from the printed circuit board surface using clean, dry, filtered compressed air or an antistatic field service

vacuum cleaner. Another method of washing the printed circuit board is:

1. Clean the printed circuit board by spraying it with isopropyl alcohol (99.5% electronic grade) or wiping the board with a foam tipped swab wetted in isopropyl alcohol.
2. When the circuit board is clean, remove excess solvent by using compressed air to blow it free of the circuit board.

EDGE CONNECTOR CLEANING

To clean edge connector contacts:

1. Use a solvent mixture of 80% isopropyl alcohol (99.5% electronic grade) and 20% distilled water.
2. Soak a lint free cloth with the solvent mixture.
3. Work the cloth back and forth parallel to the edge connector contacts.
4. Repeat with a clean cloth soaked with the solvent mixture.
5. Dry the edge connector contact area by wiping with a clean lint free cloth.

To clean tarnished or deeply stained edge connector contacts:

1. Use an Eberhard Faber (400A) pink pearl eraser or equivalent to remove tarnish or stains. Fiberglass or nylon burnishing brushes may also be used.
2. Minimize electrostatic discharge by using the 80/20 isopropyl alcohol/water solution during burnishing.
3. Do not use excessive force while burnishing. Use only enough force to shine the contact surface. Inspect the edge connector after cleaning to assure no loss of contact surface.

Checking Connections

Check all signal wiring, power and ground connections within the cabinet to verify their integrity. When checking connections, always turn a screw, nut or other fastening device in the direction to tighten only. If the connection is loose, it will be tightened. If the connection is tight, the tightening action will verify that it is secure. There must not be any motion done to loosen the connection.

NOTE: Power to the cabinet must be off while performing this task.

Verify that all cable connections are secure.

SECTION 7 - REPAIR/REPLACEMENT PROCEDURES

INTRODUCTION

Repair procedures are limited to module replacement. If the IMMFP03 Multi-Function Processor Module or IMMPIO1 interface module fails, remove and replace it with another. Verify that firmware revision levels match and that the replacement module switch and jumper settings are the same as those of the failed module.

NOTE: Do not remove an MFP module under power unless the stop/reset switch pushbutton has been depressed once and the module has halted (status LED is red and group B LEDs one through six are on). This procedure must be followed when removing an MFP module from a redundant configuration. An operational primary MFP module must halt operation before control passes to the secondary MFP module.

MODULE REPLACEMENT PROCEDURE

Observe the steps under **SPECIAL HANDLING** in Section 3 when handling MFP modules. To replace the MFP module:

1. Turn the two latching screws on the MPI and MFP modules ½-turn either way to release them.
2. Grasp the screws and slide out both modules.
3. Disconnect the auxiliary I/O ribbon cable from connector P5 on the MFP module.
4. Set dipswitches UUB0, UMB1 and LLB3, and jumpers J1 through J5 on the replacement MFP module to match the settings of the removed MFP module. Also configure the HW SETUP socket to match the setting of the removed module.
5. Connect the auxiliary I/O ribbon cable to connector P5 on the replacement module.
6. Hold both modules by the faceplate and slide them into their assigned slots. Push until the rear edges of the modules are firmly seated in the backplane connectors.
7. Turn the two latching screws on both modules ½-turn to lock the modules in place. Modules are locked into the module mounting unit when the open end of the slots on the latching screws faces the center of the module faceplate.

To replace the MPI module:

1. Turn the two latching screws on the MPI and MFP modules ½-turn to release them.
2. Grasp the screws and slide out both modules.
3. Disconnect the auxiliary I/O ribbon cable from connector P6 on the MPI module.
4. Set jumpers J1 and J2 on the replacement MPI module to match the settings of the removed MPI module.
5. Connect the auxiliary I/O ribbon cable to connector P6 on the replacement module.
6. Hold both modules by the faceplate and slide them into their assigned slots; push until the rear edges of the modules are firmly seated in the backplane connectors.
7. Turn the two latching screws on both modules ½-turn to lock the modules in place. Modules are locked into the module mounting unit when the open end of the slots on the latching screws faces the center of the module faceplate.

TERMINATION UNIT OR MODULE REPLACEMENT PROCEDURES

To replace an NTMP01 Multi-Function Processor Termination Unit, NIMP01 or NIMP02 Multi-Function Processor Termination Module, or termination cable, refer to the NTMP01, NIMP01 or NIMP02 instruction. These instructions contain step-by-step replacement procedures and spare parts information.

SECTION 8 - SUPPORT SERVICES

INTRODUCTION

Bailey Controls Company is ready to help in the use and repair of its products. Contact the nearest sales office to make requests for sales, applications, installation, repair, overhaul and maintenance contract services.

REPLACEMENT PARTS AND ORDERING INFORMATION

When making repairs, order replacement parts from a Bailey Controls Company sales office. Provide this information:

1. Part description, part number and quantity.
2. Model and serial numbers (if applicable).
3. Bailey Controls Company instruction number, page number and reference figure that identifies the part.

Order parts without commercial descriptions from the nearest Bailey Controls Company sales office. Table 8-1 lists the recommended spare parts shipped with the MFP module.

Table 8-1. Spare Parts List

Description	Part Number
Auxiliary I/O ribbon cable	1948720A60
Jumper (J1, J2, J4, J5)	1946984A1
Jumper (HW SETUP socket)	1948936A1

NOTE: It is impractical to specify a recommended quantity of spare parts, because Bailey custom designs every system. Contact Bailey for help in determining the quantity of spare parts to keep on hand for your particular system.

TRAINING

Bailey Controls Company has a modern training facility available for training your personnel. On-site training is also available. Contact a Bailey Controls Company sales office for specific information and scheduling.

TECHNICAL DOCUMENTATION

Additional copies of this instruction, or other Elsag Bailey instructions, can be obtained from the nearest Elsag Bailey sales office at a reasonable charge.

APPENDIX A - QUICK REFERENCE MATERIAL

INTRODUCTION

This appendix provides several tables for quick reference purposes. Tables A-1 through A-5 show the dipswitch settings for dipswitches UUB0, UMB1 and LLB3. Table A-6 shows the jumper settings for jumpers J1, J2, J4 and J5. Table A-7 shows the jumper settings for the HW SETUP socket. Table A-8 is an abbreviated error code listing. Table A-9 shows other LED conditions.

Table A-1. Dipswitch UUB0 Settings for MFP Operation

Pole	Setting	Function
1	0	Normal run
	1	Enable diagnostics using dipswitch UMB1
2	0	Not used. Do not change setting
3	0	Controlway (1 Mbaud)
	1	-30 VDC operation or module bus (83.3 kbaud) used

NOTE: 0 = CLOSED or ON, 1 = OPEN or OFF.

Table A-2. Dipswitch UUB0 Settings for MFP Address

Address Example	Dipswitch Pole (Binary Value)				
	4 (16)	5 (8)	6 (4)	7 (2)	8 (1)
7	0	0	1	1	1
15	0	1	1	1	1

NOTE: 0 = CLOSED or ON, 1 = OPEN or OFF.

Table A-3. Dipswitch UMB1 Options and Diagnostics

Pole	Setting	Function
1	0	Disable special operations
	1	Enable special operations. Refer to Special Operations in Section 3.
2	0	Disable on-line configuration
	1	Enable on-line configuration
3	0	Perform NVRAM checksum routine
	1	Inhibit NVRAM checksum routine ¹
4	0	Perform ROM checksum routine and file system check
	1	Inhibit ROM checksum routine and file system check
5	0	Enable file system check
	1	Disable file system check

Table A-3. Dipswitch UMB1 Options and Diagnostics (continued)

Pole	Setting	Function
6	0	Normal operation
	1	Compact configuration function ²
7	0	Normal operation
	1	Initialize NVRAM (erase configuration) memory. This pole must remain CLOSED for normal operation.
8	0	Primary MFP module
	1	Redundant MFP module ³

NOTES: 0 = CLOSED or ON, 1 = OPEN or OFF.

1. This setting is sometimes used by development personnel and should never be used for normal operation. The checksum provides additional module integrity and should be used whenever the module is controlling a process.

2. Leaving this option enabled causes the configuration to be compacted every time the module is reset, thereby increasing the start-up time. This increase becomes more substantial as the size of the configuration increases. Therefore, do not leave this option enabled longer than necessary. Disabling this option stops any further compacting operations. It does not uncompact any previously compacted configuration.

3. When redundancy is used, poles 1 through 7 on the redundant MFP module are set the same as the primary MFP module. Pole 8 is set to 0 for the primary module and to 1 for the secondary module.

Table A-4. Dipswitch UMB1 Special Operation Settings

Special Operation	Dipswitch Pole								Description
	1	2	3	4	5	6	7	8	
0	1	0	0	0	0	0	0	0	Force MFP module to configure mode.
1	1	0	0	0	0	0	0	1	Reserved for future options. Not used at this time.
2	1	0	0	0	0	0	1	0	Initialize and format all NVRAM configuration space for Plant Loop protocol.
3	1	0	0	0	0	0	1	1	Reserved. Do not use this setting.
4	1	0	0	0	0	1	0	0	INFI-NET protocol enable.
5	1	0	0	0	0	1	0	1	Permit segment modification.
6	1	0	0	0	0	1	1	0	Enable time stamping.
7	1	0	0	0	0	1	1	1	Set IMMPIO1 expected flag.

NOTE: 0 = CLOSED or ON, 1 = OPEN or OFF.

Table A-5. Dipswitch LLB3 Option Settings

Pole	Setting	Function	Default Setting
1 - 4	—	Not used	1
5	0	Disable SRAM multiple transfer	1
	1	Enable SRAM multiple transfer	
6	—	Not used	0
7	0	Disable data cache	1
	1	Enable data cache	
8	0	Disable instruction cache	1
	1	Enable instruction cache	

NOTE: 0 = CLOSED or ON, 1 = OPEN or OFF.

Table A-6. Jumpers J1, J2, J4 and J5 Settings

Jumper	Setting	Function
J1	Vertical ¹	Sets the RS-232-C diagnostic port to operate as DCE.
	Horizontal	Sets the RS-232-C diagnostic port to operate as DTE.
J2 ²	4-1	Defines SRAM device density vs. number of SRAM memory banks installed.
J4	Open	MFT disable jumper. Must remain OPEN for normal operation.
J5	30V	Disconnects Controlway for operation in module mounting units that have -30 VDC (early Network 90).
	MODB	Allows operation in module mounting units that have Controlway communication. This setting must be used if dipswitch UUB0 selects the Controlway.

NOTES:

1. Used by Bailey Controls Company service personnel. The J1 setting does not affect the module during normal operation.
2. Jumper J2 must be set to 4-1 for all firmware levels.

Table A-7. HW SETUP Socket Jumper Settings

Socket Position	Jumper Settings
1 to 16	Install the jumper for IMMFP03 modules containing firmware revision level E.0. Remove this jumper for firmware revision levels prior to E.0.
2 to 15	Install the jumper for IMMFP03 modules containing firmware revision level E.1 or greater. Remove this jumper for firmware revision levels prior to E.1.
3 to 14	Open
4 to 13	
5 to 12	
6 to 11	
7 to 10	
8 to 9	

Table A-8. Front Panel LED Error Codes

Code	LED	Condition
	8 7 6 5 4 3 2 1	
01	0 0 0 0 0 0 0 1	NVRAM checksum error
02	0 0 0 0 0 0 1 0	Analog input calibration
03	0 0 0 0 0 0 1 1	I/O module status bad
05	0 0 0 0 0 1 0 1	Configuration error (undefined block)
06	0 0 0 0 0 1 1 0	Configuration error (data type mismatch)
08	0 0 0 0 1 0 0 0	Trip block activated
0B	0 0 0 0 1 0 1 1	NVRAM initialized
0C	0 0 0 0 1 1 0 0	NVRAM opened for write
0D	0 0 0 0 1 1 0 1	Intermodule link error
0E	0 0 0 0 1 1 1 0	Redundancy IDs the same
0F	0 0 0 0 1 1 1 1	Primary failed, backup cannot take over, configuration not current
10	0 0 0 1 0 0 0 0	Primary failed, backup cannot take over, data not check pointed

Table A-8. Front Panel LED Error Codes (continued)

Code	LED								Condition
	8	7	6	5	4	3	2	1	
11	0	0	0	1	0	0	0	1	Error during write to nonvolatile memory
12	0	0	0	1	0	0	1	0	Backup and primary module addresses are different
13	0	0	0	1	0	0	1	1	ROM checksum error
14	0	0	0	1	0	1	0	0	MFP set for INFI-NET/Superloop but in a Plant Loop environment
15	0	0	0	1	0	1	0	1	RS-232-C carrier detect line error
16	0	0	0	1	0	1	1	0	Type code mismatch between primary and backup
17	0	0	0	1	0	1	1	1	Duplicate Controlway address detected
1C	0	0	0	1	1	1	0	0	IMMPI01 fault, hardware does not match configuration
20	0	0	1	0	0	0	0	0	C program format error
21	0	0	1	0	0	0	0	1	File system error
22	0	0	1	0	0	0	1	0	Invoke C error
23	0	0	1	0	0	0	1	1	User write violation
24	0	0	1	0	0	1	0	0	C program stack overflow
28	0	0	1	0	1	0	0	0	User defined function (UDF) block number reference invalid
29	0	0	1	0	1	0	0	1	UDF function block cannot read program
2A	0	0	1	0	1	0	1	0	Not enough memory for UDF
2B	0	0	1	0	1	0	1	1	Missing UDF declaration
2C	0	0	1	0	1	1	0	0	Wrong UDF type
2D	0	0	1	0	1	1	0	1	Missing UDF auxiliary
2E	0	0	1	0	1	1	1	0	UDF compiler and firmware incompatible
2F	0	0	1	0	1	1	1	1	Basic program error
30	0	0	1	1	0	0	0	0	Primary active during failover attempt
31	0	0	1	1	0	0	0	1	Memory or CPU fault
32	0	0	1	1	0	0	1	0	Address or bus error
33	0	0	1	1	0	0	1	1	Illegal instruction
34	0	0	1	1	0	1	0	0	Internal error - trace/privilege violation
35	0	0	1	1	0	1	0	1	Internal error - spurious/unassigned exception
36	0	0	1	1	0	1	1	0	Internal error - divide by 0 or check instruction
37	0	0	1	1	0	1	1	1	Internal error - undefined trap
38	0	0	1	1	1	0	0	0	Board level hardware error
3F	0	0	1	1	1	1	1	1	Normal stop
40	0	1	0	0	0	0	0	0	Backup - cold takeover ready
80	1	0	0	0	0	0	0	0	Backup - hot takeover ready
C0	1	1	0	0	0	0	0	0	Primary - operating
XX ¹	—								Unknown

NOTE:

1. This symbol represents any LED combination not specifically addressed in this table.

Table A-9. Other LED Conditions

LED	Condition	Problem
Status	Off	No power, improper module seating, jumper J4 installed or defective module
	Red	Module not properly seated or defective
	Green	None - normal operation
	Orange	Jumper J4 installed
Group B 7/8	Off	No power, improper module seating, or defective module
	Red	None - indicates primary module
Group B 8	Off	No power, improper module seating, or defective module
	Red	None - indicates secondary module in redundant configuration

APPENDIX B - ON-LINE CONFIGURATION

INTRODUCTION

Using on-line configuration in conjunction with redundant IMMFP03 and IMMFP03B Multi-Function Processor Modules enables making configuration changes without affecting the primary MFP module or interrupting the control process.

In redundant MFP module configurations, the primary MFP module executes the process control logic while the backup MFP module tracks the configuration of the primary. On-line configuration allows removing the backup (or secondary) module from the tracking mode and making configuration changes, without interrupting the process control operation of the primary module. It also supports conventional off-line changes. When the backup module has been reconfigured, it can assume control with the new configuration while the original primary module assumes the backup role.

During start-up of the new configuration in the backup module, it uses the current values of all process outputs in the primary module. This feature permits bumpless transfer of control to the new configuration.

SETUP

On-line configuration of redundant MFP modules requires two consecutive Controlway or module bus addresses to be reserved (n and $n+1$ where n is the primary address, $n+1$ is the backup). In normal operation, each member of the redundant pair has the same address as determined by the address dipswitch (UUB0) settings. (If the Controlway or module bus address of the redundant pair is at four during normal operation, then automatically the address of the backup MFP module is at five during on-line configuration.)

Set position two on the options dipswitch (UMB1) of the backup and primary MFP modules to the open position to enable on-line configuration.

OPERATION

This appendix provides a step-by-step procedure for performing on-line configuration. These standard INFI-NET configuration tools can be used to accomplish on-line configuration:

- Configuration and tuning module.
- Configuration tuning terminal.
- Operator interface station.

- Management command system.
- Engineering work station.

NOTE: Care must be exercised to avoid deleting blocks or adding blocks in the middle of existing ones. (Refer to the notes at the end of Step 2 in Table B-2 for further explanation).

In some user applications, MFP modules are remotely located and the operator is unable to view the group B LEDs. In these applications, the data from the second module status byte must be used. This appendix provides an outline procedure for on-line configuration, and shows both the state of LEDs seven and eight as well as the contents of the second module status byte (specifically bits seven, six, three and one). For each step of the on-line configuration process, both the contents of the status byte as well as the state of LEDs seven and eight (Fig. 4-1) are indicated in the margin.

The specific interface device determines how module status is acquired. For example, using an operator interface station, the status is polled by selecting the module in the PCU status display selected from the system status display. With an engineering work station using CAD/TEXT software, the problem report option must be selected. This option does not continuously poll for module status. The engineering work station user may have to invoke it multiple times until the final module status condition arises for the given step of the on-line configuration cycle. The problem report option is available in the *Modify Mode* menu of the CAD/TEXT software.

Do not reset an MFP module before the LEDs or module status byte indicate that the module is available. Resetting an MFP module prematurely could result in unpredictable operation or loss of output data.

Table B-1 shows the symbols used in this section. Table B-2 and Figure B-1 illustrate the backup cycle. Table B-3 and Figure B-2 illustrate the primary cycle. For clarity, the term

Table B-1. Legend of Symbols

Description	Primary	Backup
Module address	n	n+1
Second module status byte	Bit ¹ 7 6 5 4 3 2 1 0 0 1 x x 0 x 0 x	Bit ¹ 7 6 5 4 3 2 1 0 1 0 x x 1 x 0 x
LEDs 8 and 7. In the following tables, LED 8 is on top, LED 7 is on bottom.	● ON ○ OFF ⚙ BLINKING	

NOTE: x = don't care, 1 = bit set, 0 = bit not set.
 1. bit 7 = first time in execute (most significant bit (MSB))
 bit 6 = backup MFP module status bad
 bit 3 = on-line configuration changes being made
 bit 1 = NVRAM default configuration

backup MFP module will always refer to the original backup MFP module and the term primary MFP module will always refer to the original primary MFP module. When the roles are reversed for either unit, their status is carefully noted.

Backup Cycle

The step numbers in this cycle correspond to the status of Figure B-1.

Table B-2. Backup Cycle

Primary	Backup	Procedure
n 00xx0x0x ● ●	n+1 10xx0x0x ○ ●	1. Save a copy of the current configuration. This enables it to be easily restored if needed.
n 01xx0x0x ● ●	n+1 00xx0x0x ○ ●	2. Place the backup MFP module in configure mode. The green LED of the backup MFP module blinks indicating configure mode. The module status also indicates configure mode. Configuration commands to the backup module are sent to the address of the primary MFP module plus one (n+1). The primary module now indicates that the backup module is not available for automatic failover. Bit 6 indicates this condition. To return to Step 1 without making any changes, place the backup module in execute mode and reset it after LED 8 illuminates or the primary status indicates 00xx0x0x. Resetting an MFP module causes all the LEDs on it to light momentarily before returning to normal status.
n 01xx0x0x ● ●	n+1 00xx1x0x ☼ ○	When changes are being made to the backup module, LED 7 blinks and bit 3 of the backup module is set indicating that the configurations of the backup and primary modules do not match. If these changes to the configuration are incorrect, return to Step 1 by an initialize of the backup module NVRAM while it is in configure mode. NOTE: When configuring the backup module, the following rules are strictly enforced by the module: <ul style="list-style-type: none"> • Blocks can only be added in the block space at segment end. • A block existing in the primary module cannot be deleted. • A specification change cannot be made to a block already existing in the primary module if that change will affect the module RAM utilization factor (change memory requirements). Any attempt to circumvent these rules will result in an appropriate error message.
n 01xx0x0x ● ●	n+1 00xx1x0x ☼ ○	3. When an error exists in the new configuration, the backup module enters error mode when initiating a transfer to execute mode command. Return to configure mode to fix the error. The green LED of the backup module blinks to indicate it is in the error or configure mode. The first byte of the module status also indicates the mode. Backup module LED 7 blinks and bit 3 of the module status is set to indicate that configuration differences exist between the primary and backup.

Table B-2. Backup Cycle (continued)

Primary	Backup	Procedure
n 01xx0x0x ● ●	n+1 00xx1x0x ⚙ ○	4. The backup module can now be placed in execute mode provided no errors remain in the new configuration. Additional configuration changes can be made by entering configure mode (Step 2). If no changes have been made, a backup module reset returns the backup to the state of Step 1. If changes have been made, the backup must be put into configure mode and initialized to get to the state of Step 1. NOTE: The backup cycle step transition 3 to 4 occurs automatically after a successful Step 3 backup module execute. The transaction completion time depends on the MFP configuration.
n 01xx0x0x ● ●	n+1 10xx1x0x ○ ⚙	5. When the checkpoint data for the old configuration is received from the primary module, the reconfigured backup module can assume the role of the primary module if a failure is detected in the old configuration (Step 8). However, the primary module still indicates that no backup is available when the configuration is different. Additional configuration changes can be made by entering configure mode (Step 2). If no changes have been made, a backup module reset returns the backup to the state of Step 1. If changes have been made, the backup must be put into configure mode and initialized to get to the state of Step 1.
n 01xx0x0x ● ●	n+1 00xx1x0x ○ ○	6. After the changes have been made, tell the reconfigured backup module to assume the role of the primary module by pressing and releasing the stop/release button on the backup module 2 times. The first time stops the module; the second time resets the module. The backup module comes up in execute mode with the configuration marked as valid.
n 01xx0x0x ● ●	n+1 10xx1x0x ⚙ ○	7. Backup cycle step transitions 5 to 6 to 7 to 8 occur automatically after the Step 5 backup module reset. The time it takes to complete these transitions depends on MFP configuration. The status indicated in cycles 5, 6 and 7 may not be seen depending on the actual step transition times. The important status to wait on is indicated by Step 8. After the checkpoint data is updated, the backup module is ready to take over the duties of the primary module.
n 01xx0x0x ● ●	n+1 11xx1x0x ○ ⚙	8. The backup module requests the primary module to shut down and assume the role of a hot backup (n+1). The backup module waits to act as the primary module (n). A hot backup retains the old configuration and control data and is ready to assume control if an error is detected in the new configuration.
n+1 01xx0x0x ○ ●	n 01xx1x0x ⚙ ⚙	9. The primary module has removed the bus clock (BUSCLK) and acts as a hot backup (n+1). The reconfigured backup module is now serving as the primary module (n). Before proceeding to the following commands, insure that LED/module status is as shown in Step 8. To return to Step 4, reset the backup module (n). This allows correcting a bad configuration. The primary module (n+1) must be reset at this point in order for the on-line configuration cycle to complete. Resetting the primary module (n+1), currently acting as the hot backup, tells it to get a copy of the new configuration.
n+1 10xx0x0x ○ ●	n 00xx0x0x ● ●	10. After the backup module copies the new configuration into the primary module, the cycle is complete. The backup module is now serving as the primary module (n) while the primary handles the backup role (n+1). The LED combination and module status is the opposite of Step 1, indicating the role reversal.

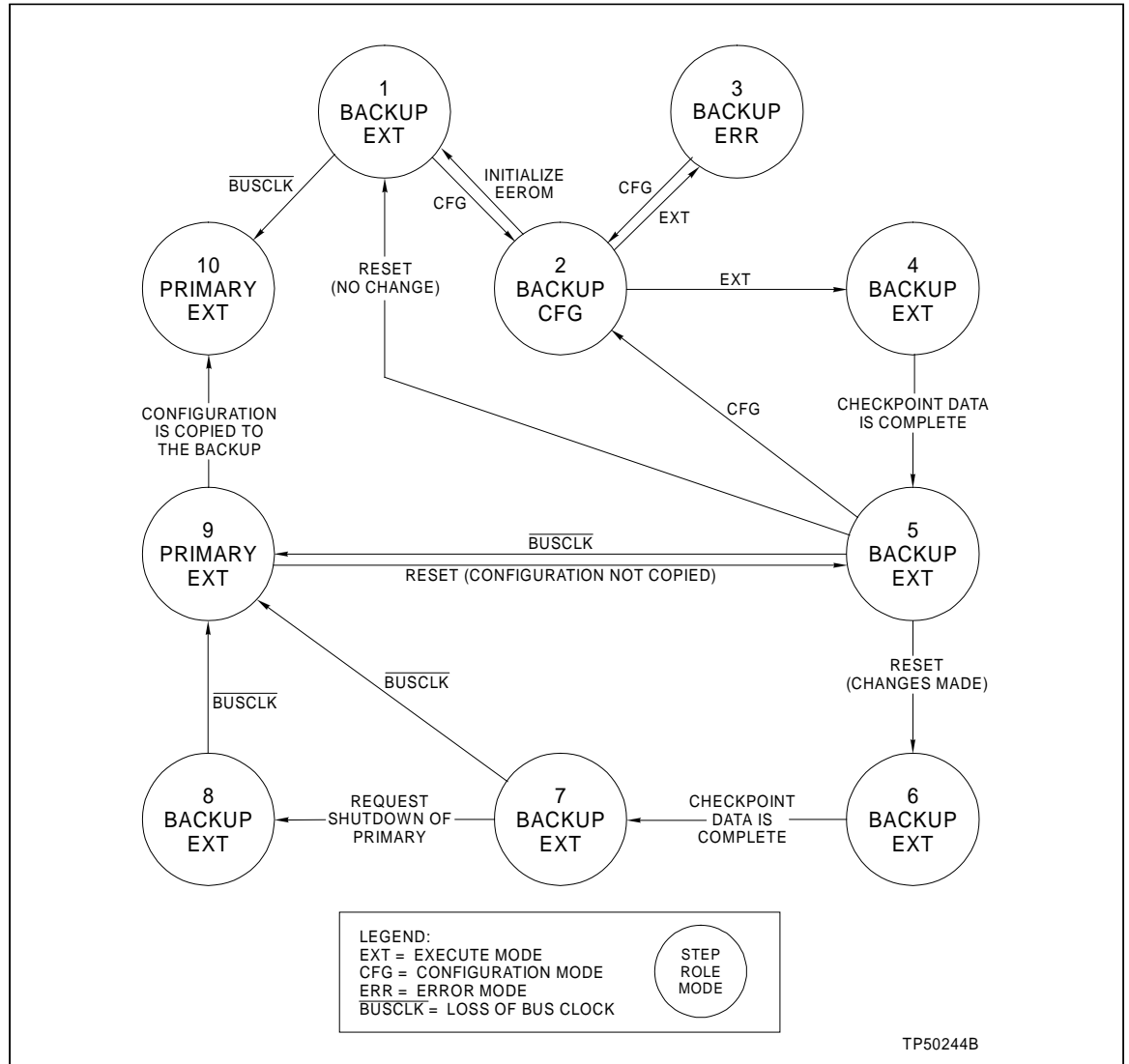

Figure B-1. Backup MFP Module Operating Cycle

Primary Cycle

Refer to Table B-3 for the primary cycle procedure. The step numbers in this cycle correspond to the states of Figure B-2. This information is provided for status purposes. Follow the backup cycle procedures to perform on-line configuration,

Table B-3. Primary Cycle

Primary	Backup	Procedure
n 01xx0x0x ● ●	n+1 10xx1x0x ○ ⊗	1. The primary module is actively controlling the process. This represents the same juncture as Step 4 of the backup cycle.
n+1 01xx0x0x ○ ●	n 11xx1x0x ⊗ ⊗	2. When the shutdown request is received from the backup module (Step 7 of the backup cycle), the primary module stops executing and removes the bus clock (BUSCLK).
n+1 01xx0x0x ○ ●	n 01xx1x0x ⊗ ⊗	3. The primary module is now acting as the hot backup (n+1). All old configuration and block output information remains intact from when it is shut down in Step 2. If the new configuration is not operating as expected, the primary module, currently acting as the hot backup (n+1), can take control using the old configuration and block output information (returns to Step 1).
n+1 00xx0x0x ○ ○	n 00xx1x0x ⊗ ⊗	4. Resetting the primary module (n+1), currently acting as the hot backup, directs it to get a copy of the new configuration (Step 8 of the backup cycle).
n+1 10xx0x0x ● ○	n 00xx0x0x ● ●	5. When the new configuration has been copied, the backup module has completed its cycle and is now serving as the primary module.
n+1 10xx0x0x ○ ●	n 00xx0x0x ● ●	6. After the checkpoint data is complete, the primary module is now serving as the backup module and is ready to take over the control process with the updated configuration. The primary cycle is complete. This represents the same juncture as Step 10 of the backup cycle.

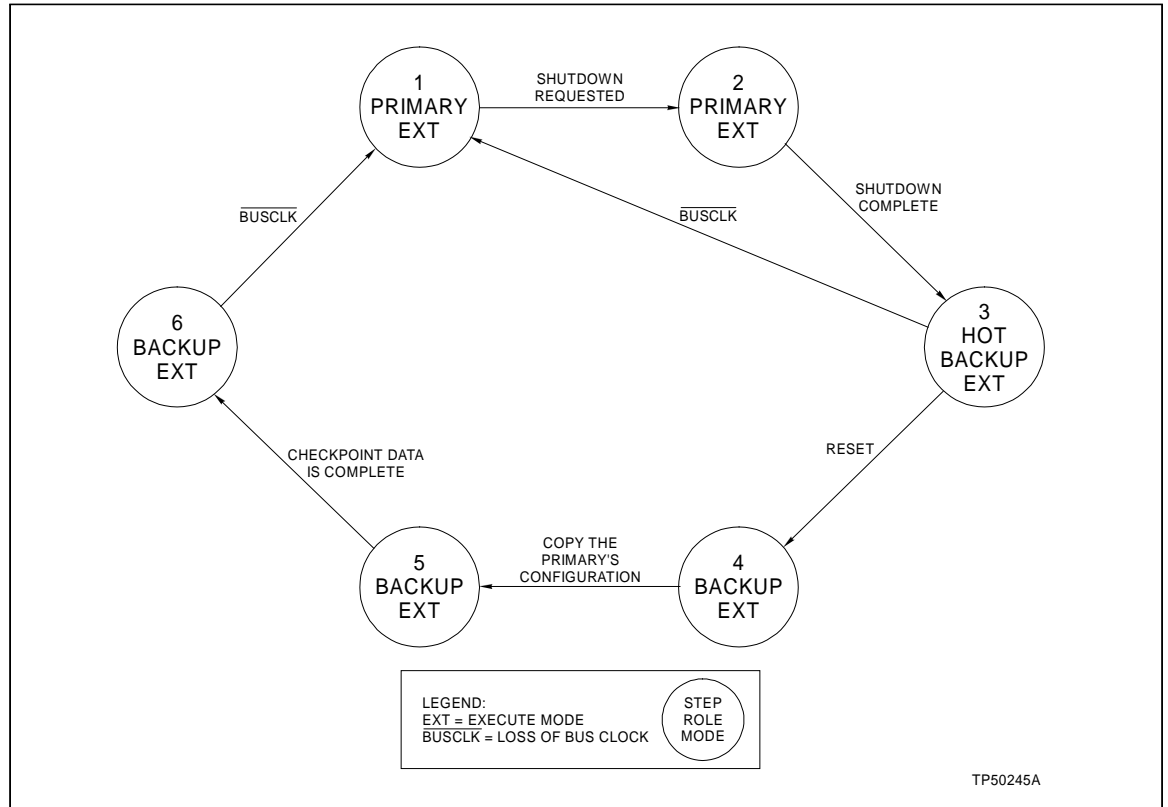

Figure B-2. Primary MFP Module Operating Cycle

APPENDIX C - NTMP01 CONFIGURATION

INTRODUCTION

The IMMFP03 and IMMFP03B Multi-Function Processor Module, through the IMMPIO1 Multi-Function Processor Interface Module, can use the NTMP01 termination unit for termination. Jumpers on the NTMP01 termination unit configure the two RS-232-C ports for data terminal equipment (DTE) or data communication equipment (DCE). One of the RS-232-C ports can be configured as an RS-485 port. Refer to the NTMP01 product instruction for complete information on applications.

Figures C-1 through C-4 show the jumper configurations for jumpers J1 and J2. Figure C-5 shows the jumper configurations for jumpers J3 through J10. Figure C-6 shows the jumper configurations for jumpers J14 through J17. Figure C-7 shows the NTMP01 connector assignments and jumper locations. Figure C-8 shows the cable connections for redundant IMMPIO1 and IMMFP03 modules.

Jumpers J11 and J12 are storage posts for extra jumpers. Jumper J13 is normally set with pins one and two connected. This connects the cable shielding pin of connector P7 to chassis ground. Jumper J18 configures the terminal serial port for RS-485 operation when pins two and three are connected and connector P7 is used instead of connector P5.

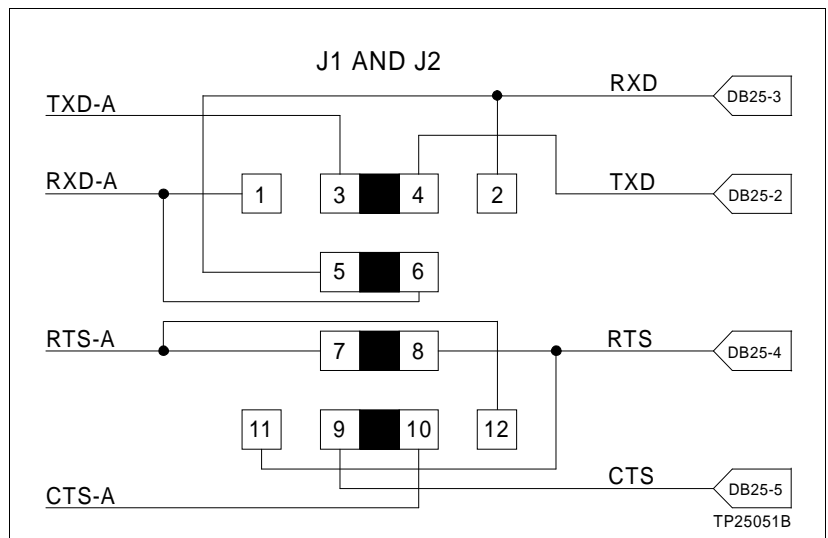

Figure C-1. NTMP01 DTE Jumper Configuration

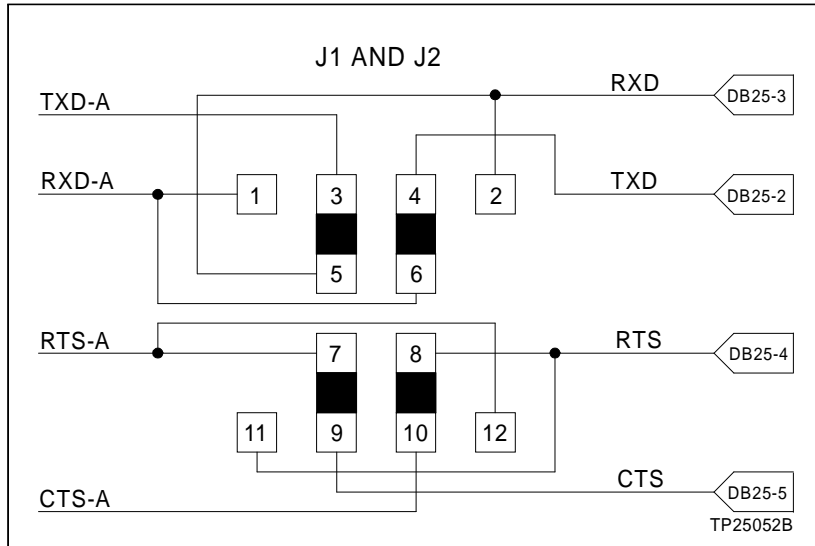

Figure C-2. NTMP01 DCE Jumper Configuration

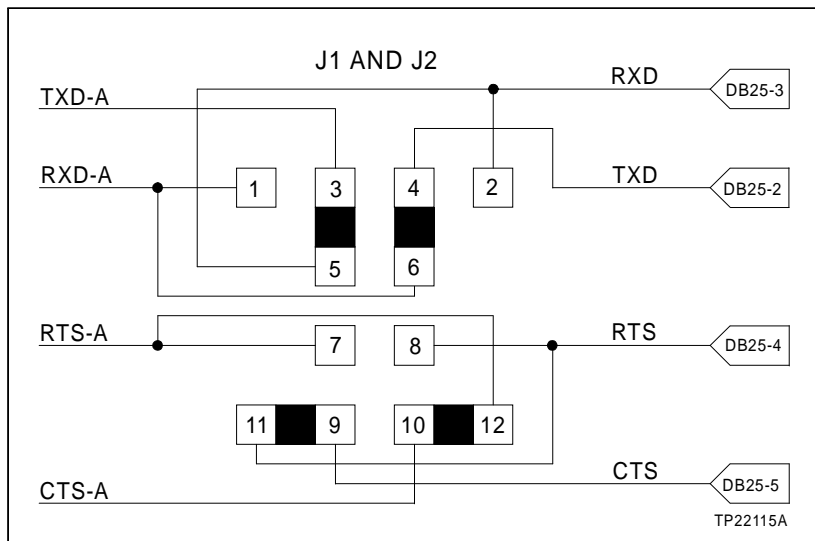

Figure C-3. NTMP01 Nonhandshake Jumper Configuration

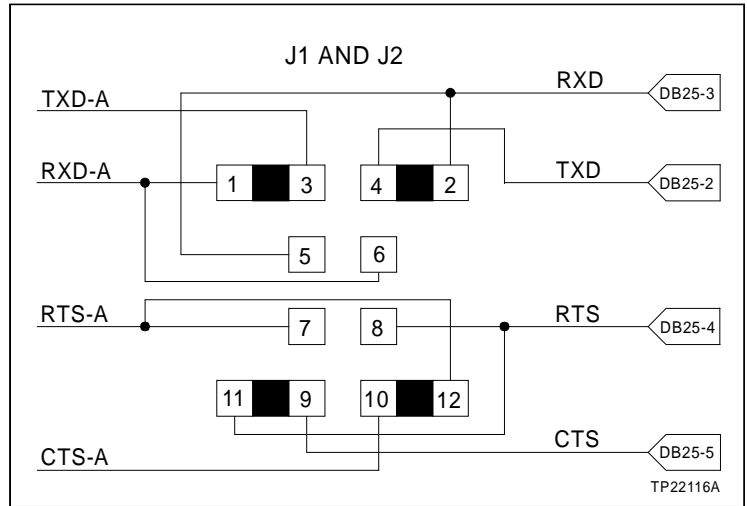

Figure C-4. NTMP01 Loopback Jumper Configuration

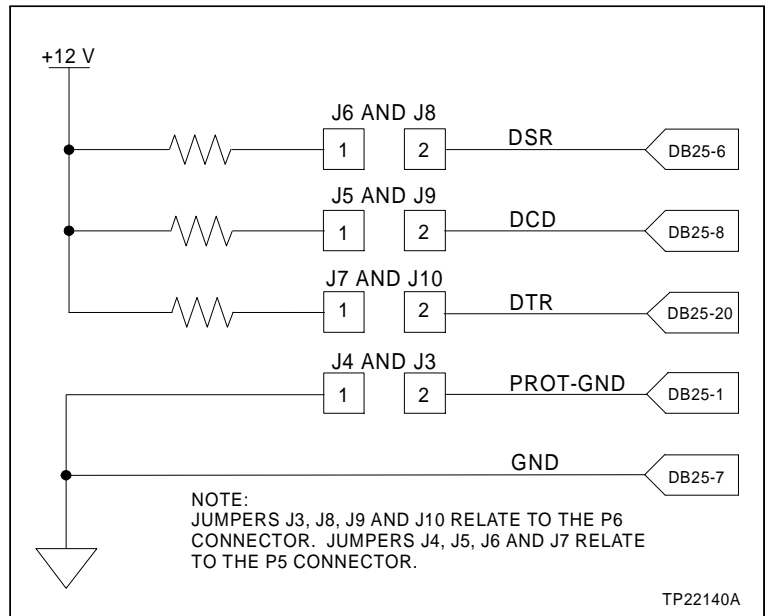

Figure C-5. NTMP01 Jumpers J3 through J10 Configuration

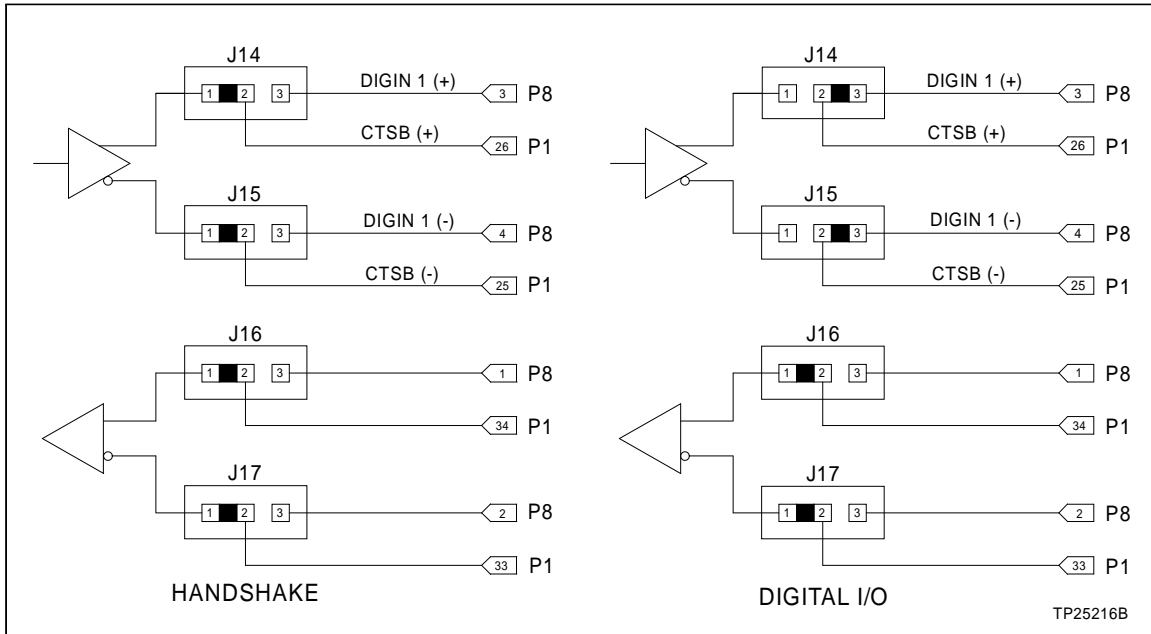

Figure C-6. NTMP01 Jumpers J14 through J17 Configuration

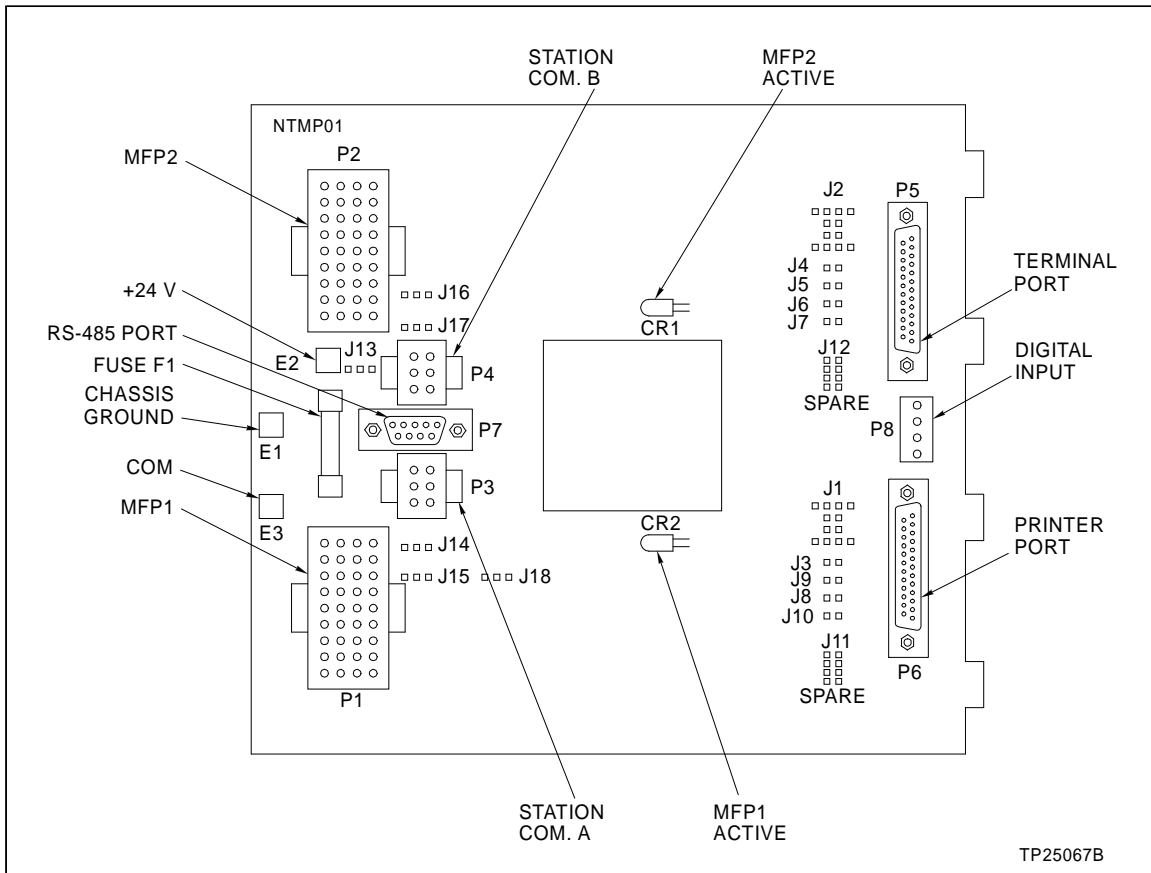

Figure C-7. NTMP01 Connector Assignments and Jumper Locations

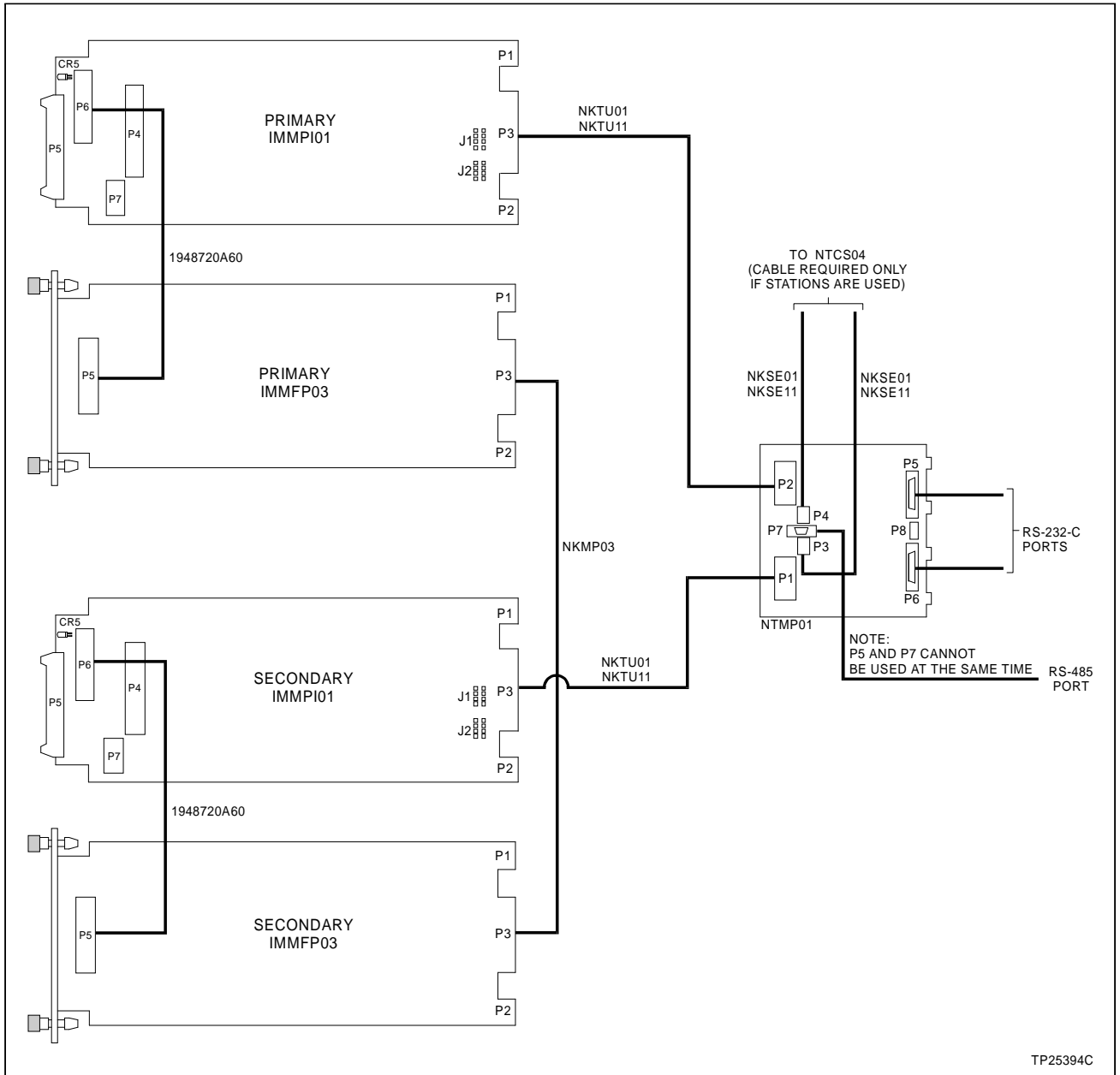

Figure C-8. NTMP01 Cable Connections for Redundant IMMFP03 and IMMPIO1 Modules

APPENDIX D - NIMP01 AND NIMP02 CONFIGURATION

INTRODUCTION

The IMMFP03 and IMMFP03B Multi-Function Processor Modules, through the IMMPIO1 Multi-Function Processor Interface Module, can use the NIMP01 and NIMP02 termination modules for termination. Jumpers on the NIMP01 termination module configure the two RS-232-C ports for data terminal equipment (DTE) or data communication equipment (DCE). One of the RS-232-C ports can be configured as an RS-485 port. The NIMP02 termination module is required when installing redundant MFP modules. Refer to the NIMP01 and NIMP02 product instruction for complete information on termination module applications.

Figures D-1 through D-4 show the jumper configurations for jumpers J1 and J2. Figure D-5 shows the jumper configurations for jumpers J5 through J10, J19 and J20. Figure D-6 shows the jumper configurations for jumpers J14 through J17. Figure D-7 shows the NIMP01 connector and jumper locations. Figure D-8 shows the cable connections for a single IMMFP03 or IMMPIO1 module. Figure D-9 shows the cable connections for redundant IMMPIO1 and IMMFP03 modules.

Jumpers J11 and J12 are storage posts for extra jumpers. Jumper J13 is normally set with pins one and two connected. Jumper J18 configures the terminal serial port for RS-485 operation when pins two and three are connected and connector P7 is used instead of connector P5.

NOTES:

1. RS-232-C port connections on the termination module are through DB-9 connectors. Use Elsag Bailey cable NKMR02 to connect a standard piece of equipment (computer or printer with a DB-25 connector) to the termination module.
2. There are no jumper settings on the NIMP02 termination module. Refer to Figure D-9 for cable connections.

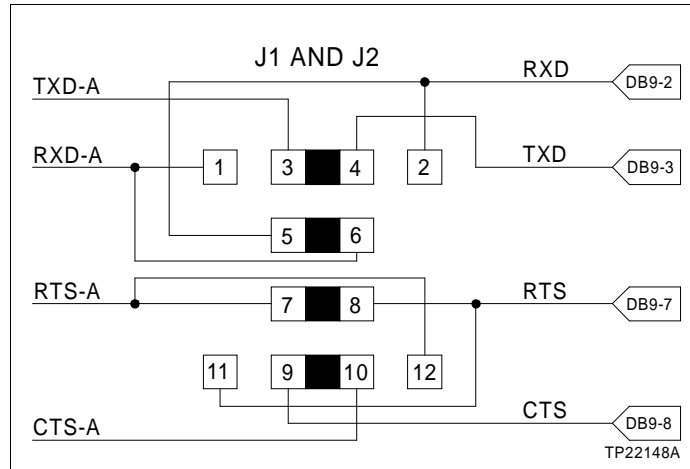

Figure D-1. NIMP01 DTE Jumper Configuration

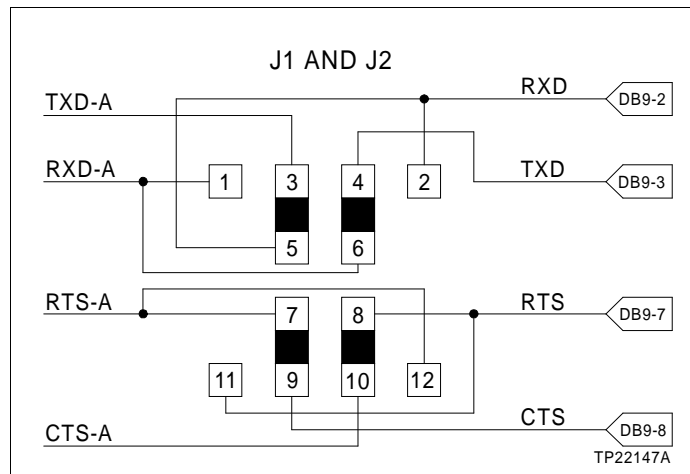

Figure D-2. NIMP01 DCE Jumper Configuration

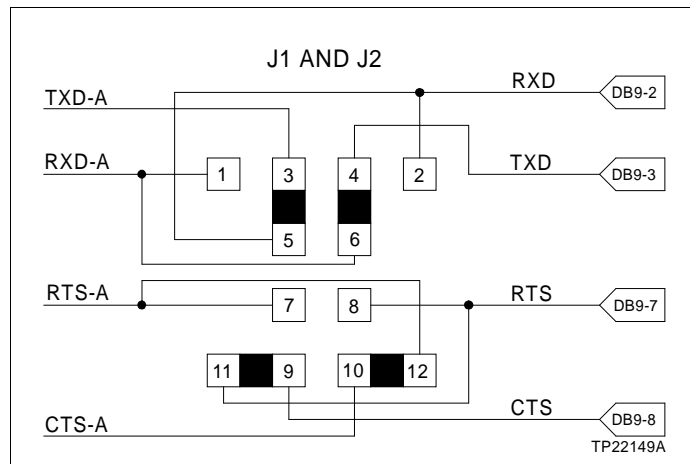

Figure D-3. NIMP01 Nonhandshake Jumper Configuration

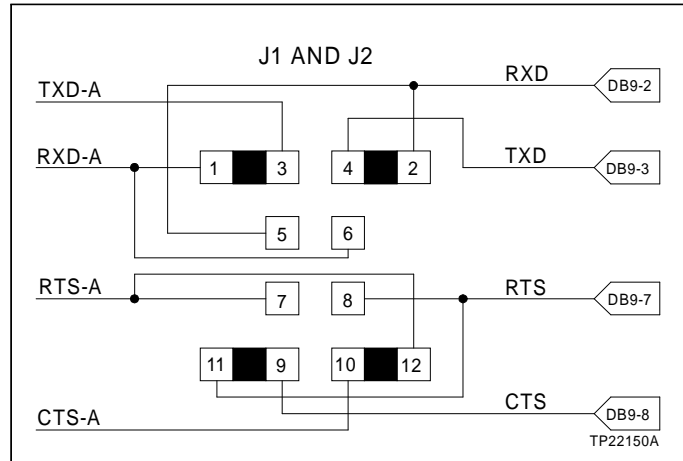

Figure D-4. NIMP01 Loopback Jumper Configuration

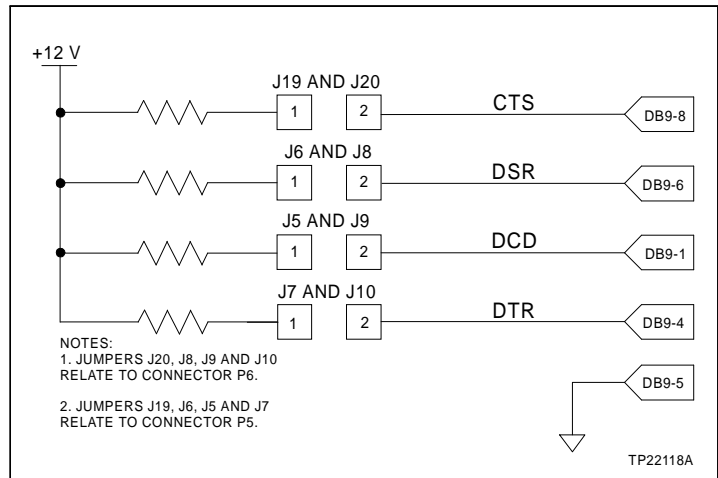

Figure D-5. NIMP01 Jumpers J5 through J10 Configuration

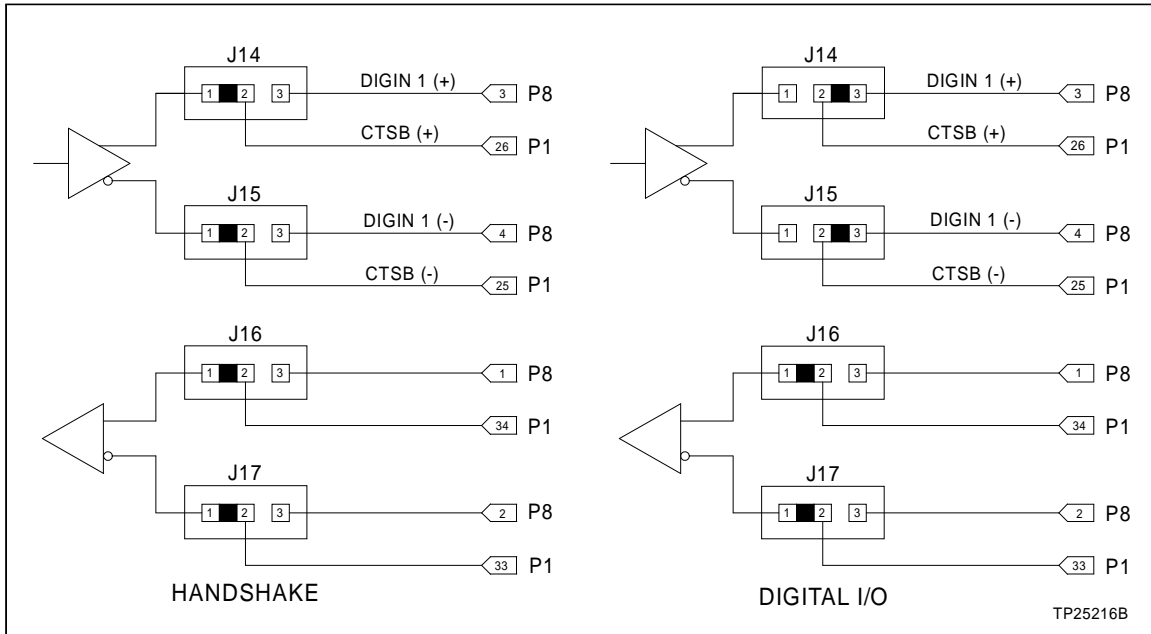

Figure D-6. NIMP01 Jumpers J14 through J17 Configuration

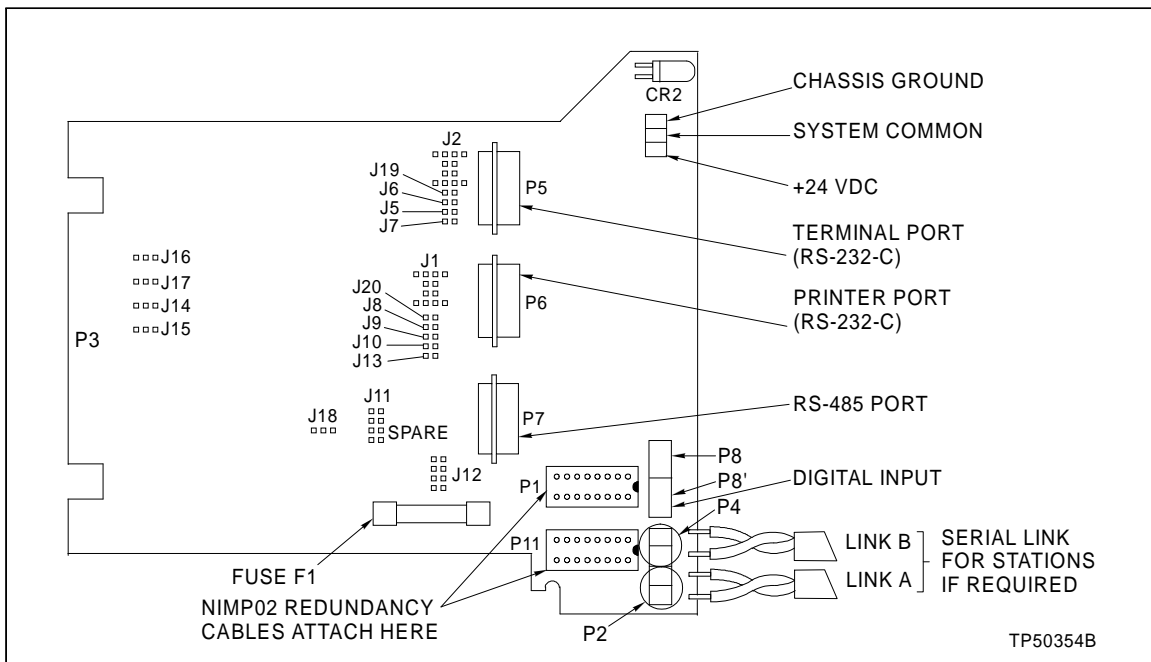

Figure D-7. NIMP01 Connector Assignments and Jumper Locations

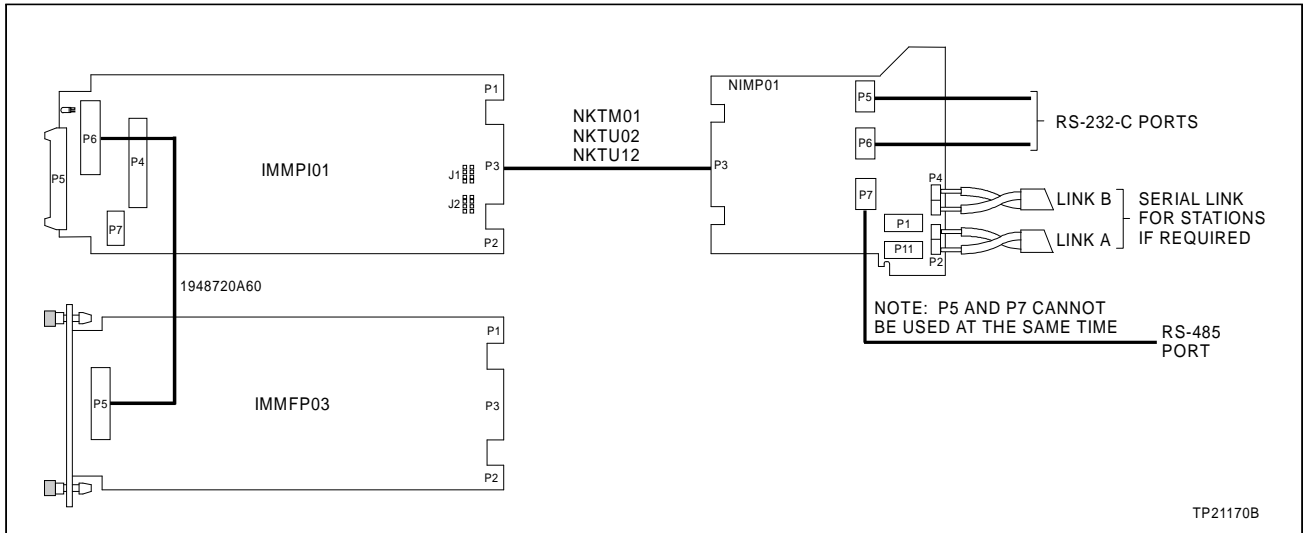

Figure D-8. NIMP01 Cable Connections for Single MFP and MPI Modules

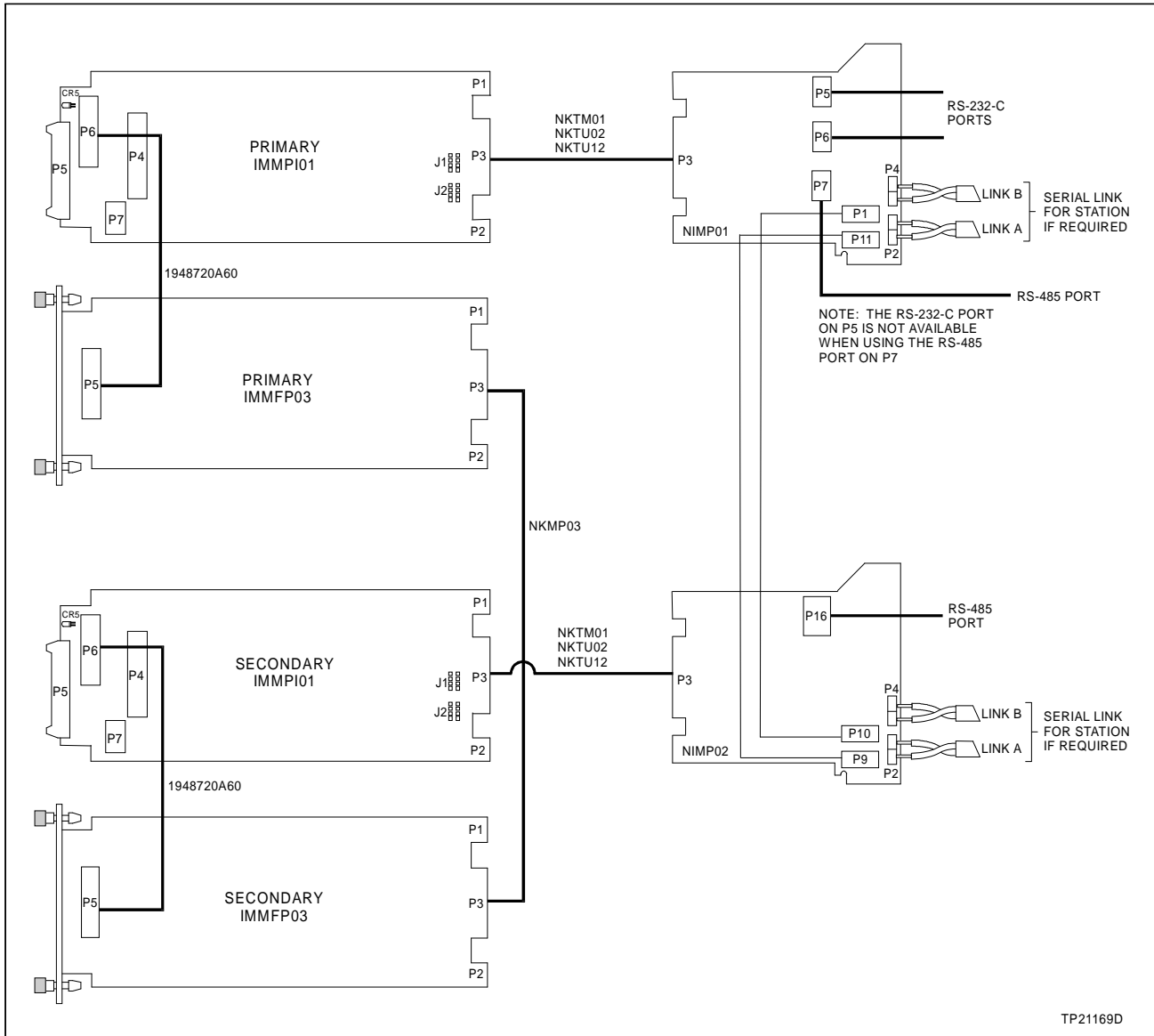

Figure D-9. NIMP01 and NIMP02 Cable Connections for Redundant MFP and MPI Modules

Index

A	
Abbreviations.....	1-4
C	
Cables	
Controlway.....	3-10
MFP.....	1-5
Module bus.....	3-10
MPI.....	1-5, 8-1
Termination module.....	1-5, 3-11, D-5, D-6
Termination unit.....	1-5, 3-11, C-5
Circuitry	
MFP	
Clock.....	2-3
Controlway.....	2-4
DMA.....	2-3
I/O.....	2-5
I/O expander bus.....	2-5
Memory.....	2-3
Microprocessor.....	2-2
Redundancy link.....	2-4
MPI	
Serial channels.....	2-6
Station link.....	2-7
Configure mode.....	4-4
Connector pin assignments	
MFP	
P1.....	5-5
P2.....	5-6
P3.....	5-6
P4.....	5-6
MPI	
P1.....	5-6
P3.....	5-7
D	
Diagnostics.....	3-4, 5-7
Dipswitch positions.....	5-8
Tests.....	5-9
Dipshunts.....	3-10
Dipswitch	
IMDSO04, S1.....	5-8
MFP	
LLB3.....	A-2
LMB2.....	3-6, 5-8
UMB1.....	3-4, 5-8, A-1
UUB0.....	3-3, 5-8, A-1
Documentation.....	8-1

E	
Error	
Codes.....	5-1, A-3
Mode.....	4-4
Example applications.....	1-2, C-5, D-5, D-6
Execute mode.....	4-4
F	
Faceplate	
MFP.....	4-2
MPI.....	4-5
Function blocks.....	1-1, 4-4
Function codes.....	1-1, 4-4
G	
Glossary.....	1-4
H	
Hardware	
Configuration.....	A-1
MFP.....	3-2
MPI.....	3-8
Description.....	1-1
How to use this instruction.....	1-4
I	
I/O expander bus.....	2-5, 3-10
Installation	
Dipshunts.....	3-10
MFP.....	3-12
MPI.....	3-12
Termination module.....	3-11
Termination unit.....	3-11
Instruction content.....	1-3
J	
Jumpers	
MFP	
HW SETUP.....	3-8, 8-1, A-3
J1, J2, J4, J5.....	3-7, 8-1, A-3
MPI	
J1.....	3-9, 8-1
J2.....	3-9, 8-1

Index (continued)

NIMP01/02			
J1 and J2	D-2		
J14 through J17	D-4		
J5 through J10	D-3		
NTMP01			
J1 and J2	C-1		
J14 through J17	C-4		
J3 through J10	C-3		
L			
LEDs			
MFP			
Group A LEDs	1-2, 4-2, 5-10		
Group B LEDs	1-2, 2-5, 4-2, 5-1, A-3		
Start-up sequences	4-1		
Status	4-3		
Status LED	1-2, 2-5		
MPI	4-5		
M			
Machine fault timer	3-7		
Maintenance schedule	6-1		
MFP module layout	3-3		
Module			
Bus	3-10		
Installation	3-12		
Mounting unit preparation	3-9		
Replacement procedures	7-1		
Status report	5-11		
MPI module layout	3-8		
N			
NIMP01/02 termination module layout	D-4		
Nomenclature	1-5		
NTMP01 termination unit layout	C-4		
O			
On-line configuration	B-1		
P			
Parts ordering information	8-1		
R			
Redundancy	2-4		
References	1-5		
S			
SCSI	3-6		
Software configuration	4-4		
Spare parts	8-1		
Special handling precautions	3-1		
Special operations	3-5		
Special terms	1-4		
Specifications			
MFP	1-6		
MPI	1-6		
Start-up sequences	4-1		
Station support	2-7		
Stop/reset switch	4-3		
T			
Termination device			
Installation	3-11		
Replacement procedures	7-2		
Training	8-1		
Troubleshooting	5-1		
Flowcharts	5-4, 5-5		
U			
Unpacking and inspection	3-2		
Usable memory	2-3		
User qualifications	1-1		

For prompt, personal attention to your instrumentation and control needs or a full listing of Bailey representatives in principal cities around the world, contact the Bailey location nearest you.

Australia

Elsag Bailey Pty. Limited
Regents Park, NSW
Phone: 61-2-645-3322
Telefax: 61-2-645-2212

Japan

Bailey Japan Company, Ltd.
Tagata-Gun, Shizuoka-Ken
Phone: 81-559-49-3311
Telefax: 81-559-49-1114

United Kingdom

Bailey Automation plc
Telford, Shropshire
Phone: 44-1952-670-477
Telefax: 44-1952-670-455

Brazil

Bailey do Brasil
São Paulo
Phone: 55-11-548-4122
Telefax: 55-11-547-0315

Jordan

Bailey Controls Jordan
Amman
Phone: 962-6-788-116
Telefax: 962-6-756-908

United States

Bailey Controls Company
Wickliffe, Ohio
Phone: 1-216-585-8500
Telefax: 1-216-585-8756

Canada

Elsag Bailey (Canada), Inc.
Burlington, Ontario
Phone: 1-905-639-8840
Telefax: 1-905-639-8639

Mexico

Bailey Mexico S.A. de C.V.
Naucalpan
Phone: 52-5-557-6100
Telefax: 52-5-557-7022

Venezuela

Bailey de Venezuela SA
Valencia
Phone: 58-41-329-196
Telefax: 58-41-327-632

France

Elsag Bailey S.A.
Massy
Phone: 33-1-64-47-2000
Telefax: 33-1-64-47-2016

Norway

Bailey Norge A.S.
Bergen
Phone: 47-55-222-000
Telefax: 47-55-222-010

Germany

Bailey-F & P Automation GmbH
Overath
Phone: 49-220-473-90
Telefax: 49-220-473-979

People's Republic of China

Bailey Beijing Controls
Beijing
Phone: 86-10-401-0651
Telefax: 86-10-401-1643

Italy

Elsag Bailey
Genoa
Phone: 39-10-658-1
Telefax: 39-10-658-2941

Singapore

Elsag Bailey Pte. Ltd.
Singapore
Phone: 65-442-3200
Telefax: 65-442-2700

CONTACT US & SUPPORT

NEED A QUOTE OR TECHNICAL PARTS REPLACEMENT?

Company: [PLC ProTech Ltd.](#)
Website: www.plcprotech.com
Email: sales@plcprotech.com
Phone: +86 180 4631 7198

Our Service Guarantee:

- 100% Brand New Original & Factory Sealed Components
- 12-Month Quality Warranty on All Industrial Parts
- Worldwide Same-Day Fast Dispatch via DHL / FedEx

[SUBMIT ONLINE RFQ \(REQUEST FOR QUOTE\) >>](#)

[About Us](#) · [Contact](#) · [All Products](#)