

# ***Technical Product Guide***

## *Tricon v10 Systems*

---

|   |    |
|---|----|
| Introduction .....                          | 1  |
| Theory of Operation .....                   | 3  |
| System Configuration .....                  | 11 |
| Product Specifications .....                | 17 |
| Field Termination Options.....              | 55 |
| Communication Capabilities .....            | 67 |
| TriStation 1131 Developer’s Workbench ..... | 71 |
| CEM Programming Language Editor .....       | 75 |
| Sequence of Events (SOE) Capability .....   | 77 |
| Safety View ABM .....                       | 79 |
| Part Number Cross-Reference .....           | 81 |
| Glossary.....                               | 85 |

## *Preface*

Information in this document is subject to change without notice. Companies, names and data used in examples herein are fictitious unless otherwise noted. No part of this document may be reproduced or transmitted in any form or by any means, electronic or mechanical, for any purpose, without the express written permission of Invensys Systems, Inc.

© 2006–2012 Invensys Systems, Inc. All rights reserved.

Invensys, the Invensys logo, Foxboro, I/A Series, ArchestrA, InTouch, Triconex, Tricon, Trident, and TriStation are trademarks of Invensys plc, its subsidiaries and affiliates. All other brands may be trademarks of their respective owners.

### DISCLAIMER

Because of the variety of uses for this equipment and because of the differences between this fault-tolerant equipment and traditional programmable logic and process controllers, the user of, and those responsible for applying, this equipment must satisfy themselves as to the acceptability of each application and the use of the equipment.

The illustrations, charts and layout examples shown in this manual are intended solely to illustrate the text of this manual. Because of the many variables and requirements associated with any particular installation, Invensys Systems, Inc. cannot assume responsibility or liability for actual use based upon the illustrative uses and applications.

In no event will Invensys Systems, Inc. be responsible or liable for indirect or consequential damages resulting from the use or application of this equipment.

INVENSYS SYSTEMS, INC. DISCLAIMS ANY IMPLIED WARRANTY OF FITNESS FOR A PARTICULAR PURPOSE.

Invensys Systems, Inc. reserves the right to make changes at any time in order to improve design and to supply the most reliable product. No patent or copyright liability is assumed by Invensys Systems, Inc. with respect to use of information, circuits, equipment or software described in this text.

### TECHNICAL SUPPORT

Customers in the U.S. and Canada can obtain technical support from the Invensys Global Customer Support (GCS) center at the numbers below. International customers should contact their regional support center.

|            |                  |                             |
|------------|------------------|-----------------------------|
| Telephone: | Toll-free number | 866-746-6477                |
|            | Toll number      | 508-549-2424 (outside U.S.) |
| Fax:       | Toll number      | 508-549-4999                |

*The Tricon fault-tolerant controller is based on a Triple-Modular Redundant (TMR) architecture.*

## Introduction

### What Is Fault-Tolerant Control?

A fault-tolerant control system identifies and compensates for failed control system elements and allows repair while continuing an assigned task without process interruption. A high-integrity control system such as the Tricon™ controller is used in critical process applications that require a significant degree of safety and availability.

### What Is the Tricon Controller?

The Tricon is a state-of-the-art controller that provides fault tolerance by means of Triple-Modular Redundant (TMR) architecture. TMR integrates three isolated, parallel control systems and extensive diagnostics in one control system. The system uses two-out-of-three voting to provide high-integrity, error-free, uninterrupted process operation.

The Tricon controller uses three identical channels. Each channel independently executes the control program in parallel with the other two channels. Specialized hardware/software voting mechanisms qualify and verify all digital inputs and outputs from the field, while analog inputs are subject to a mid-value selection process.

Because each channel is isolated from the others, no single-point failure in any channel can pass to another. If a hardware failure occurs on one channel, the other channels override it. Meanwhile, the faulting module can easily be removed and replaced, while the



**The Tricon Fault-Tolerant Controller**

controller is online, without interrupting the process.

Setting up control programs is simplified with the triplicated Tricon system, because it operates as a single control system from the user's point of view. The user terminates sensors and actuators at a single wiring terminal and programs the Tricon controller with one

set of control program logic. The Tricon controller manages the rest!

Extensive diagnostics on each channel, module, and functional circuit immediately detect and report operational faults by means of indicators or alarms.

All diagnostic fault information is accessible by the control program and the operator. The program or the operator can use diagnostic data to modify

## Introduction

control actions or direct maintenance procedures.

Other key features of the Tricon controller that ensure the highest possible system integrity are:

- Ability to operate with three, two, or one Main Processors before shutdown
- Fully implemented and transparent triplication
- Comprehensive system diagnostics
- Complete range of I/O modules
- Dual and single I/O modules for safety-critical points with a limited need for availability
- Remote I/O up to 7.5 miles (12 kilometers) away from the MPs
- Simple, online module repair
- Unsurpassed reliability and availability

### What Are Typical User Applications?

Each day the Tricon controller supplies increased safety, reliability, and availability to a worldwide installed base. The following are a few typical applications. For more information on how a Tricon controller can add value to your applications, ask your sales representative for additional documentation and customer references.

### Emergency Safety Shutdown (ESD)

The Tricon controller provides continuous protection for safety-critical units in refineries, petrochemical/chemical plants, and other industrial processes. For example, in reactor and compressor units, plant-trip signals—for pressure, product feed rates, expander pressure equalization and temperature—are monitored, and shutdown actions taken if an upset condition occurs. Traditional

shutdown systems—implemented with mechanical or electronic relays—provide shutdown protection but can also cause dangerous nuisance trips.

The Tricon controller increases system integrity, providing automatic detection and verification of field sensor integrity, integrated shutdown and control functionality, and direct connection to the supervisory data highway for continuous monitoring of safety-critical functions.

### Boiler Flame Safety

Process steam boilers function as a critical component in most refinery applications. Protection of the boiler from upset conditions, safety interlock for normal startup and shutdown, and flame-safety applications are combined by one integrated Tricon system. In traditional applications, these functions had to be provided by separate, non-integrated components. But with the fault-tolerant, fail-safe Tricon controller, the boiler operations staff can use a critical resource more productively while maintaining safety at or above the level of electromechanical protection systems.

### Turbine Control Systems

The control and protection of gas or steam turbines requires high integrity as well as safety. The continuous operation of the fault-tolerant Tricon controller provides the turbine operator with maximum availability while maintaining equivalent levels of safety. Speed control as well as start-up and shutdown sequencing are implemented in a single integrated system. Unscheduled outages are avoided by using *hot-spares* for the I/O modules. If a fault occurs in a module, a replacement module is automatically activated without operator intervention.

### Offshore Fire and Gas Protection

The protection of offshore platforms from fire and gas threats requires continuous availability as well as reliability. The Tricon controller provides this availability through *online replacement* of faulty modules. Faults in individual modules, field wiring, and sensors are managed automatically by built-in diagnostics. Analog fire and gas detectors are connected directly to the Tricon, eliminating the need for trip amps. An operator interface monitors fire and gas systems as well as diagnostics for the Tricon controller and its attached sensors. Traditional fire and gas panels can be replaced with a single integrated system, saving costly floor space while maintaining high levels of safety and availability.

### What Is TriStation 1131?

TriStation™ 1131 Developer's Workbench is an integrated tool for developing, testing and documenting control programs that execute in the Tricon controller. The TriStation 1131 software complies with the IEC 61131 International Standard for Programmable Controllers and follows the Microsoft® Windows® guidelines for graphical user interfaces.

### What About Communication Capabilities?

Optional modules enable the Tricon controller to communicate with other Triconex® controllers and with other hosts such as:

- Modbus masters and slaves
- Distributed Control Systems (DCS)
- Operator workstations
- Host computers using Ethernet (802.3) protocol

For more information, see “Communication Capabilities” on page 67.

*The Tricon controller is designed with a fully triplicated architecture throughout, from the input modules through the Main Processors (MPs) to the output modules.*

## Theory of Operation

Triple Modular Redundant (TMR) architecture ensures fault tolerance and provides error-free, uninterrupted control in the presence of either hard failures of components or transient faults from internal or external sources.

Every I/O module houses the circuitry for three independent channels. Each channel on the input modules reads the process data and passes that information to its respective Main Processor. The three Main Processors communicate with each other using a proprietary high-speed bus system called the TriBus.

sate for errors that occur between the Main Processor and the final output driven to the field.

Each I/O slot can contain two identical I/O modules, which means if a fault is detected on one module, control is automatically switched to the healthy module. A faulty module can also be replaced online when only one module is installed in the spare slot. In this case, a healthy module is inserted in the spare slot and the control is switched to this module, which allows the faulty module to be pulled and sent for repair.

As each input module is polled, the appropriate channel of the I/O bus transmits new input data to the Main Processor. The input data is assembled into a table in the Main Processor and is stored in memory for use in the hardware voting process.

The individual input table in each Main Processor is transferred to its neighboring Main Processors over the TriBus. During this transfer, hardware voting takes place. The TriBus uses a direct memory access programmable device to synchronize, transmit, vote, and compare data among the three Main Processors.

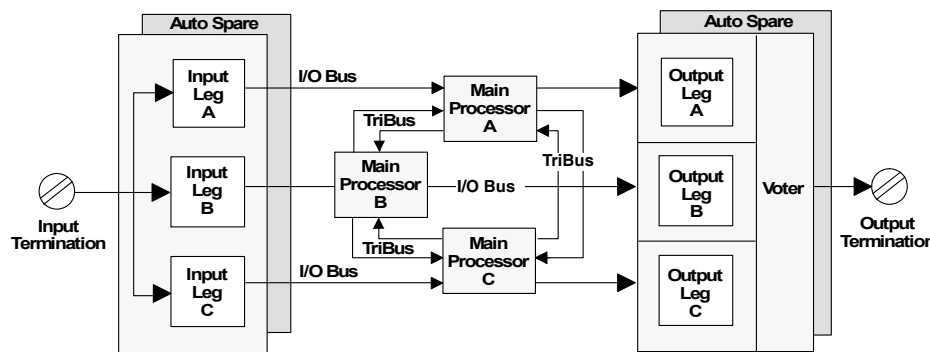

**Simplified Tricon System Architecture**

Once per scan, the Main Processors synchronize and communicate with their neighbors over the TriBus. The TriBus votes digital input data, compares output data, and sends copies of analog input data to each Main Processor. The Main Processors execute the control program and send outputs generated by the control program to the output modules. The Tricon controller votes the output data on the output modules as close to the field as possible to detect and compen-

### Main Processor Modules

A Tricon controller contains three Main Processor modules. Each Main Processor controls a separate channel of the system and operates in parallel with the other Main Processors. A dedicated I/O Processor on each Main Processor manages the data exchanged between the Main Processor and the I/O modules. A triplicated I/O bus, located on the chassis backplane, extends from chassis to chassis by means of I/O bus cables.

If a disagreement occurs, the signal value found in two out of three tables prevails, and the third table is corrected accordingly. One-time differences which result from sample timing variations are distinguished from a pattern of differing data. Each Main Processor maintains data about necessary corrections in local memory. Any disparity is flagged and used at the end of the scan by the Tricon controller built-in fault analyzer routines to determine whether a fault exists on a particular module.

The Main Processors put corrected data into the control program. The 32-bit main microprocessor executes the control program in parallel with the neighboring Main Processor modules.

The control program generates a table of output values which are based on the table of input values according to customer-defined rules built into the control program. The I/O Processor on

# Theory of Operation

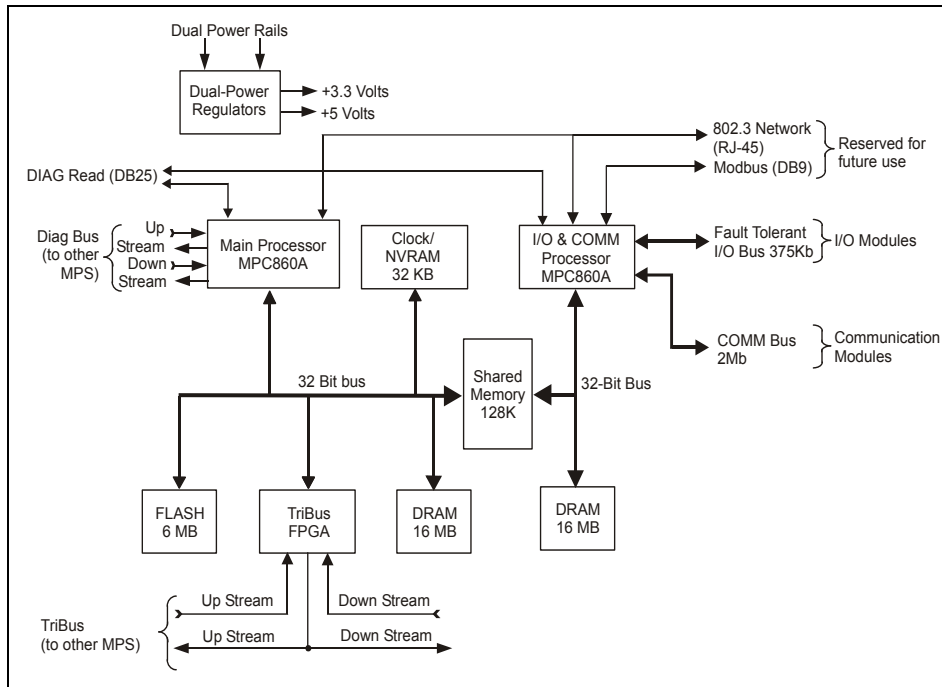

**Main Processor (Model 3008) Architecture**

each Main Processor manages the transmission of output data to the output modules by means of the I/O bus.

Using the table of output values, the I/O Processor generates smaller tables, each corresponding to an individual output module in the system. Each small table is transmitted to the appropriate channel of the corresponding output module over the I/O bus. For example, Main Processor A transmits the appropriate table to Channel A of each output module over I/O Bus A. The transmittal of output data has priority over the routine scanning of all I/O modules. The I/O Processor manages the data exchanged between the Main Processors and the communication modules using the communication bus which supports a broadcast mechanism.

Main Processors receive power from dual Power Modules and power rails in the Main Chassis. A failure on one

Power Module or power rail does not affect system performance.

## Bus Systems and Power Distribution

Three triplicated bus systems are etched on the chassis backplane: the TriBus, the I/O bus, and the communication bus.

### TriBus

The TriBus consists of three independent serial links which synchronizes the Main Processors at the beginning of a scan, and performs either of these functions:

- Transfers I/O, diagnostic, and communication data.
- Compares data and flags disagreements of output or memory data from the previous scan.

An important feature of Tricon controller architecture is the use of a single transmitter to send data to both the upstream and downstream Main

Processors, which ensures the same data is received by the upstream processor and downstream processor.

### I/O Bus

Each I/O module transfers signals to or from the field through its associated field termination assembly. Two positions in the chassis tie together as one logical slot. Termination cables are tied to panel connectors at the top of the backplane. Each connection extends from the termination module to both active and hot-spare I/O modules, which means both the active module and the hot-spare module receive the same information from the field termination wiring.

The triplicated I/O bus transfers data between the I/O modules and the Main Processors at 375 kilobits per second. The I/O bus is carried along the bottom of the backplane. Each channel of the I/O bus runs between one Main Processor and the corresponding channels on the I/O module. The I/O bus extends between chassis using a set of three I/O bus cables.

### Communication Bus

The communication (COMM) bus runs between the Main Processors and the communication modules at 2 megabits per second.

### Power Distribution

Power for the chassis is distributed across two independent power rails and down the center of the backplane. Each module in the chassis draws power from both power rails through dual power regulators. There are four sets of power regulators on each input and output board: one set for each channel (A, B, and C) and one set for the status indicators.

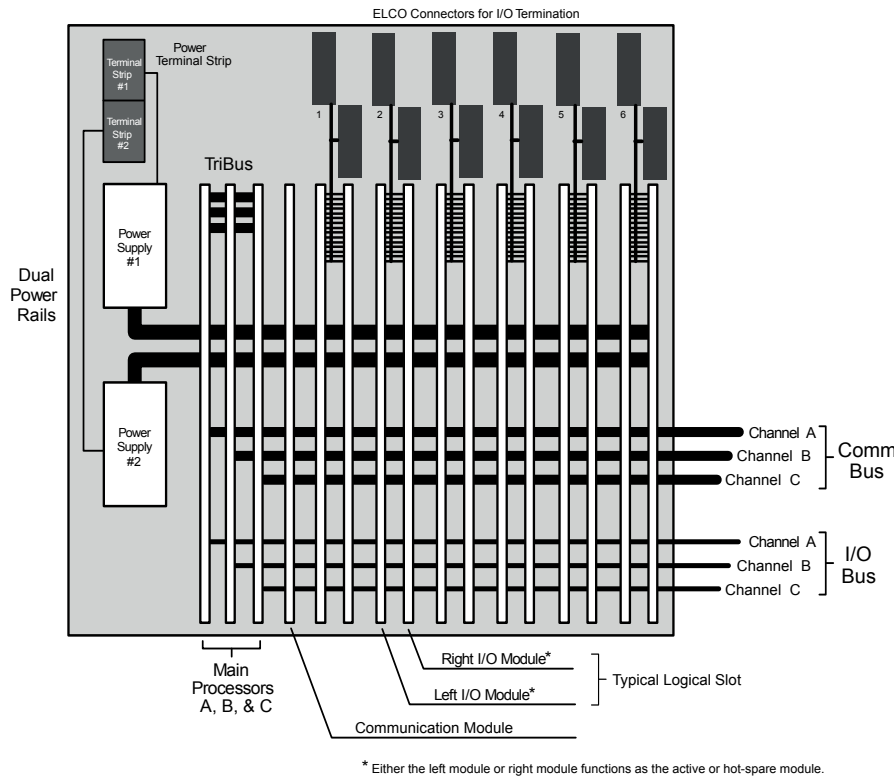

**Tricon Bus Systems and Power Distribution**

**Field Signals**

Each I/O module transfers signals to or from the field through its associated field termination panel. Two positions in the chassis tie together as one logical slot. The first position holds the active I/O module and the second position holds the hot-spare I/O module. Termination cables are connected to the top of the backplane. Each connection extends from the termination panel to both active and hot-spare I/O modules. Therefore, both the active module and the hot-spare module receive the same information from the field termination wiring.

**Digital Input Modules**

The Tricon controller supports two basic types of Digital Input Modules: TMR and Single. The following paragraphs describe Digital Input Modules

in general, followed by specifics for TMR and Single modules.

Every Digital Input Module houses the circuitry for three identical channels (A, B, and C). Although the channels reside on the same module, they are completely isolated from each other and operate independently. A fault on one channel cannot pass to another. In addition, each channel contains an 8-bit microprocessor called the I/O communication processor, which handles communication with its corresponding Main Processor.

Each of the three input channels asynchronously measures the input signals from each point on the input module, determines the respective states of the input signals, and places the values into input tables A, B, and C respectively. Each input table is regularly interrogated over the I/O bus by the I/O

communication processor located on the corresponding Main Processor. For example, Main Processor A interrogates Input Table A over I/O Bus A.

On TMR Digital Input Modules, all critical signal paths are 100 percent triplicated for guaranteed safety and maximum availability. Each channel conditions signals independently and provides isolation between the field and the Tricon controller. (The Model 3504E High-Density Digital Input Module is an exception—it has no channel-to-channel isolation.)

DC models of the TMR Digital Input Modules can self-test to detect stuck-ON conditions where the circuitry cannot tell whether a point has gone to the OFF state. Because most safety systems use a de-energize-to-trip setting, the ability to detect the Off state is an important feature. To test for stuck-On inputs, a switch within the input circuitry is closed to allow a zero input (Off) to be read by the optical isolation circuitry. The last data reading is frozen in the I/O Processor while the test is running.

On Single Digital Input Modules, only those portions of the signal path which are required to ensure safe operation are triplicated. Single modules are optimized for those safety-critical applications where low cost is more important than maximum availability. Special self-test circuitry detects all stuck-On and stuck-Off fault conditions within the non-triplicated signal conditioners in less than half a second. This is a mandatory feature of a fail-safe system, which must detect all faults in a timely manner and, upon detection of an input fault, force the measured input value to the safe state. Because the Tricon is optimized for de-energize-to-trip applications, detection of a fault in the input circuitry forces to Off (the de-energized state) the value reported to the Main Processors by each channel.

# Theory of Operation

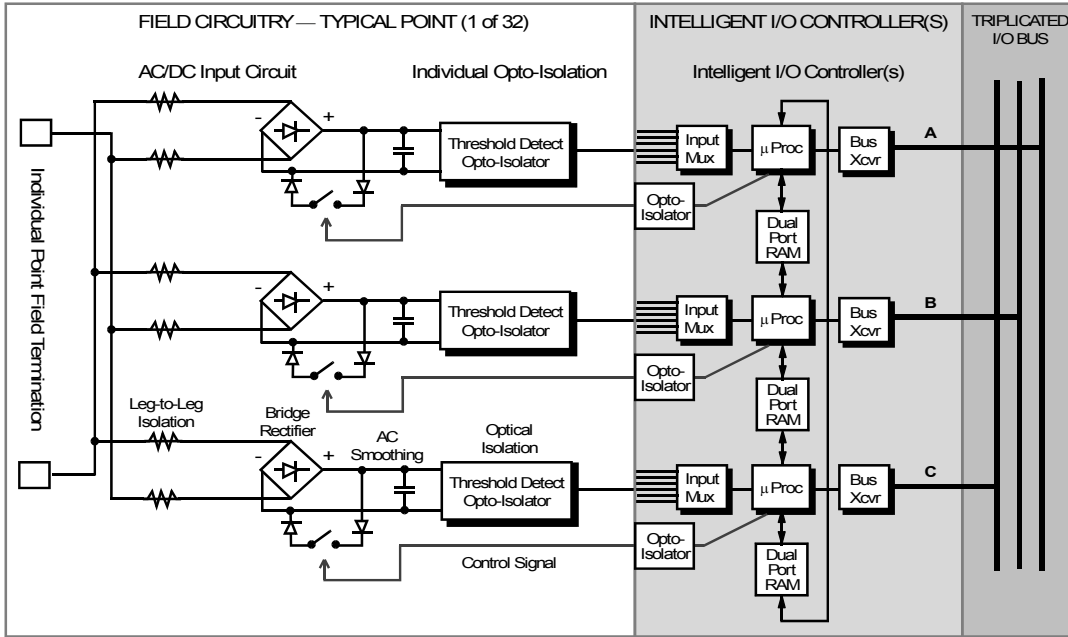

Architecture of TMR Digital Input Module with Self-Test (DC Model)

channels B and C, or channels A and C command them to close—in other words, 2-out-of-3 drivers voted On. The quadruplicated voter circuitry provides multiple redundancy for all critical signal paths, guaranteeing safety and maximum availability.

Each type of Digital Output Module executes a particular Output Voter Diagnostic (OVD) for every point. Loop-back on the module allows each microprocessor to read the output value for the point to determine whether a latent fault exists within the output circuit.

## Digital Output Modules

There are four basic types of Digital Output Modules: dual, supervised, DC voltage and AC voltage. The following paragraphs describe Digital Output Modules in general, followed by specifics for the four types.

Every Digital Output Module houses the circuitry for three identical, isolated channels. Each channel includes an I/O microprocessor which receives its output table from the I/O communication processor on its corresponding Main Processor. All of the Digital Output Modules, except the dual DC modules, use a patented quadruplicated output circuitry, referred to as *Quad Voter*, which votes on the individual output signals just before they are applied to the load. This

voter circuitry is based on parallel-series paths which pass power if the drivers for channels A and B, or

the point to determine whether a latent fault exists within the output circuit.

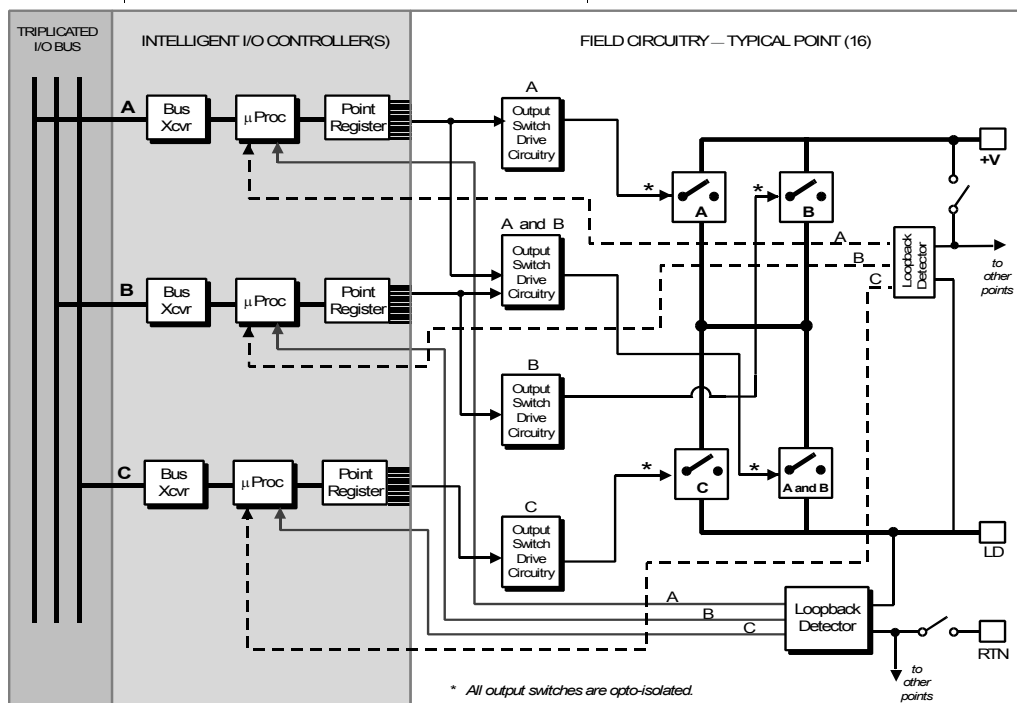

Architecture of 16-Point Supervised Digital Output Module

## Analog Input Modules

On an Analog Input Module, each of the three channels asynchronously measures the input signals and places the results into a table of values. Each of the three input tables is passed to its associated Main Processor module using the I/O bus. The input table in each Main Processor is transferred to its neighbors across the TriBus. The middle value is selected by each Main Processor, and the input table in each Main Processor is corrected accordingly. In TMR mode, the mid-value data is used by the control program; in duplex mode, the average is used.

Each Analog Input Module is automatically calibrated using multiple reference voltages read through the multiplexer. These voltages determine the gain and bias that are required to adjust readings of the analog-to-digital converter (ADC).

Analog Input Modules and termination panels are available to support a wide variety of analog inputs, in both isolated and non-isolated versions: 0-5 VDC, -5 to +5 VDC, 0-10 VDC, 4-20 mA, thermocouples (types K, J, T, E), and resistive thermal devices (RTDs).

### Analog Output Module

The Analog Output Module receives three tables of output values, one for each channel from the corresponding Main Processor. Each channel has its own digital-to-analog converter (DAC). One of the three channels is selected to drive the analog outputs. The output is continuously checked for correctness by “loop-back” inputs on each point which are read by all three microprocessors. If a fault occurs in the driving channel, that channel is declared faulty and a new channel is selected to drive the field device. The

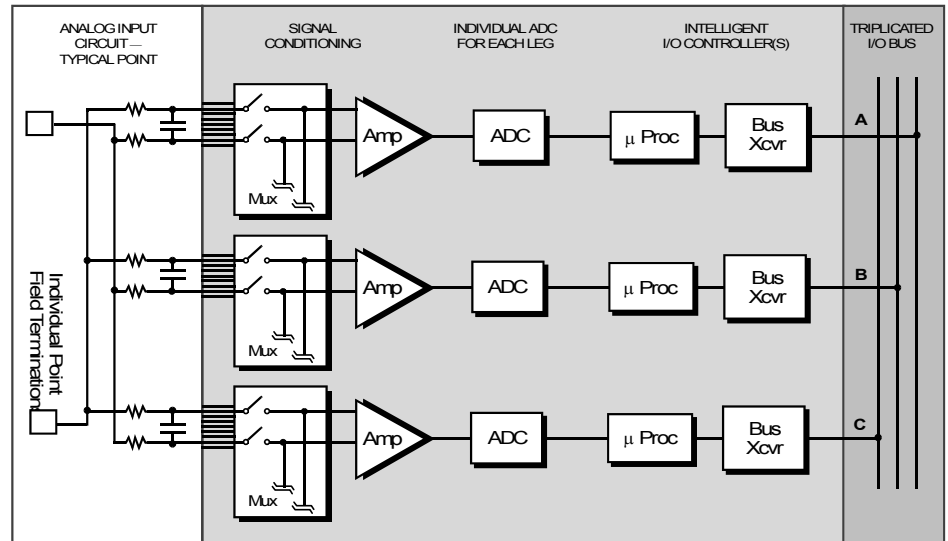

Architecture of TMR Analog Input Module

designation of “driving channel” is rotated among the channels, so that all three channels are tested.

### Field Terminations

Various termination options are available for field wiring of the Tricon chassis, including external termination panels (ETPs) and fanned-out cables.

An ETP is an electrically-passive printed circuit board to which field wiring is easily attached. An ETP passes input signals from the field to an input module or passes signals generated by an output module directly to field wiring, thereby permitting removal or replacement of the input or output module without disturbing field wiring.

A fanned-out cable is a lower-cost alternative to an ETP when using Digital Input Modules or Digital Output Modules. One end of a fanned-out cable connects to the Tricon controller backplane and the other end provides 50 fanned-out leads, each individually labeled with a pin number that matches the connector signals.

## Communication Modules

By means of the communication modules described in this section, the Tricon controller can interface with Modbus masters and slaves, other Triconex controllers in a Triconex peer-to-peer network, external hosts on Ethernet networks, and Honeywell™ and Foxboro® distributed control systems (DCS). The Main Processors broadcast data to the communication modules across the communication bus. Data is typically refreshed every scan; it is never more than two scan-times old. For more information, see “Communication Capabilities” on page 67.

### Tricon Communication Module (TCM)

The Tricon Communication Module (TCM) enables a Tricon controller to communicate with Modbus devices (masters or slaves), a TriStation 1131 PC, a network printer, other Triconex controllers, and other external devices on Ethernet networks.

Each TCM has four serial ports, two Ethernet network ports, and one debug port (for Invensys use).

# Theory of Operation

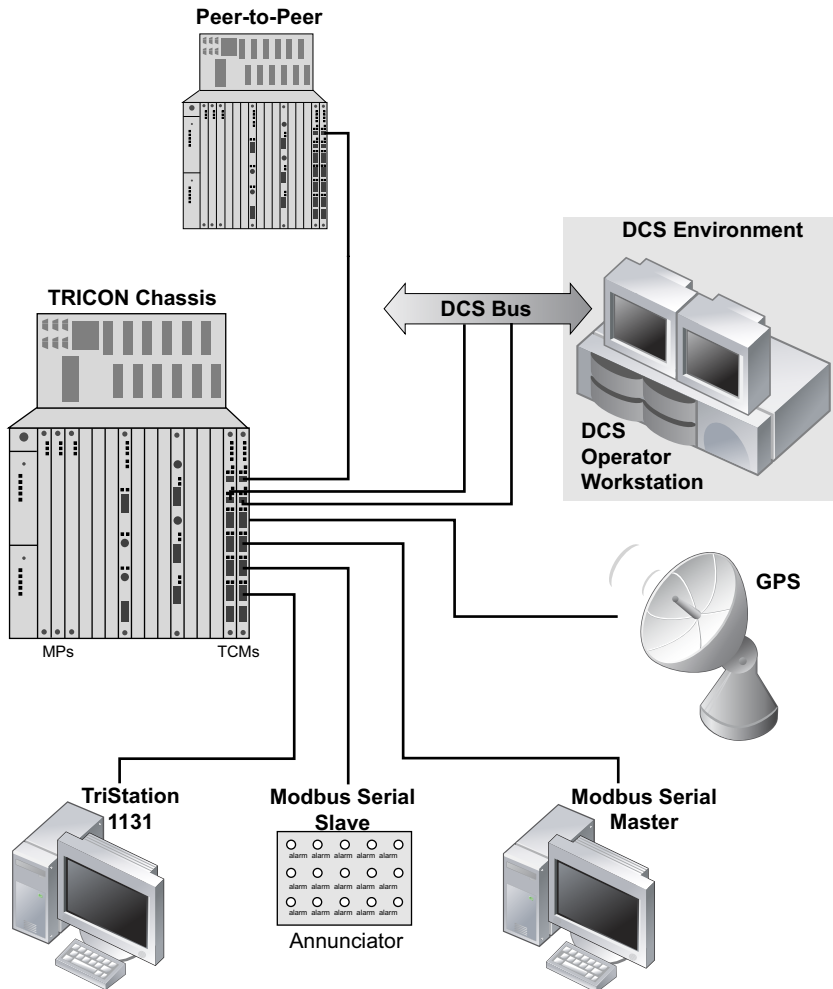

Sample of the TCM Communication Capabilities

A single Tricon controller supports up to four TCMs, which reside in two logical slots. This arrangement provides a total of sixteen serial ports and eight Ethernet network ports.

### Enhanced Intelligent Communication Module (EICM)

The EICM enables a Tricon controller to communicate with Modbus devices (masters or slaves), with a TriStation 1131 PC, and with a printer. The four serial ports are uniquely addressed and can be used for Modbus or TriStation communication at speeds up to 19.2 kilobits per second. A single Tricon High-Density controller supports up to

two EICM modules which reside in one logical slot. This arrangement provides a total of six Modbus ports, two TriStation ports, and two printer ports.

### Network Communication Module (NCM)

The NCM supports Ethernet (802.3) communication at 10 megabits per second for Triconex-proprietary protocols and applications.

The NCM also supports OPC Server which can be used by any OPC client. In addition, users can write their own applications using the TSAA protocol.

The NCMG enables time synchronization to a GPS device.

### Hiway Interface Module (HIM)

The HIM acts as an interface between a Tricon controller and a Honeywell TDC-3000 Distributed Control System (DCS) by means of the Hiway Gateway and Local Control Network (LCN). The HIM enables higher-order devices, such as computers and operator workstations, to communicate with the Tricon.

### Safety Manager Module (SMM)

The SMM acts as an interface between a Tricon controller and a Honeywell Universal Control Network (UCN), one of three principal networks of the TDC-3000 DCS. The SMM appears to the TDC-3000 as a safety node on the Universal Control Network (UCN), allowing the Tricon controller to manage process-critical points within the overall TDC-3000 environment. The SMM transmits all Tricon aliased data and diagnostic information to TDC-3000 operator workstations in display formats that are familiar to Honeywell operators.

### Advanced Communication Module (ACM)

The ACM acts as an interface between a Tricon controller and a Foxboro Intelligent Automation (I/A) Series DCS. The ACM appears to the Foxboro system as a safety node on the I/A Series<sup>®</sup> Nodebus, allowing the Tricon controller to manage process-critical points within the overall I/A DCS environment. The ACM transmits all Tricon aliased data and diagnostic information to I/A operator workstations in display formats that are familiar to Foxboro operators.

See "Product Specifications" on page 17 for specifications of the TCM, EICM, NCM, SMM, HIM, and ACM.

### HART Communication

Highway Addressable Remote Transducer protocol (HART™) is a bi-directional industrial field communication protocol used to communicate between intelligent field instruments and host systems over 4-20 mA instrumentation wiring. Invensys offers these components to enable HART communication between HART devices in the field and Configuration and Asset Management Software running on a PC:

- Model 2770H HART Analog Input Interface Module
- Model 2870H HART Analog Output Interface Module

### Power Modules

Each Tricon chassis houses two Power Modules arranged in a dual-redundant configuration. Each module derives power from the backplane and has independent power regulators for each channel. Each can support the power requirements for all the modules in the chassis in which it resides, and each feeds a separate power rail on the chassis backplane. The Power Modules have built-in diagnostic circuitry which checks for out-of-range voltages and over-temperature conditions. A short on a channel disables the power regulator rather than affecting the power bus.

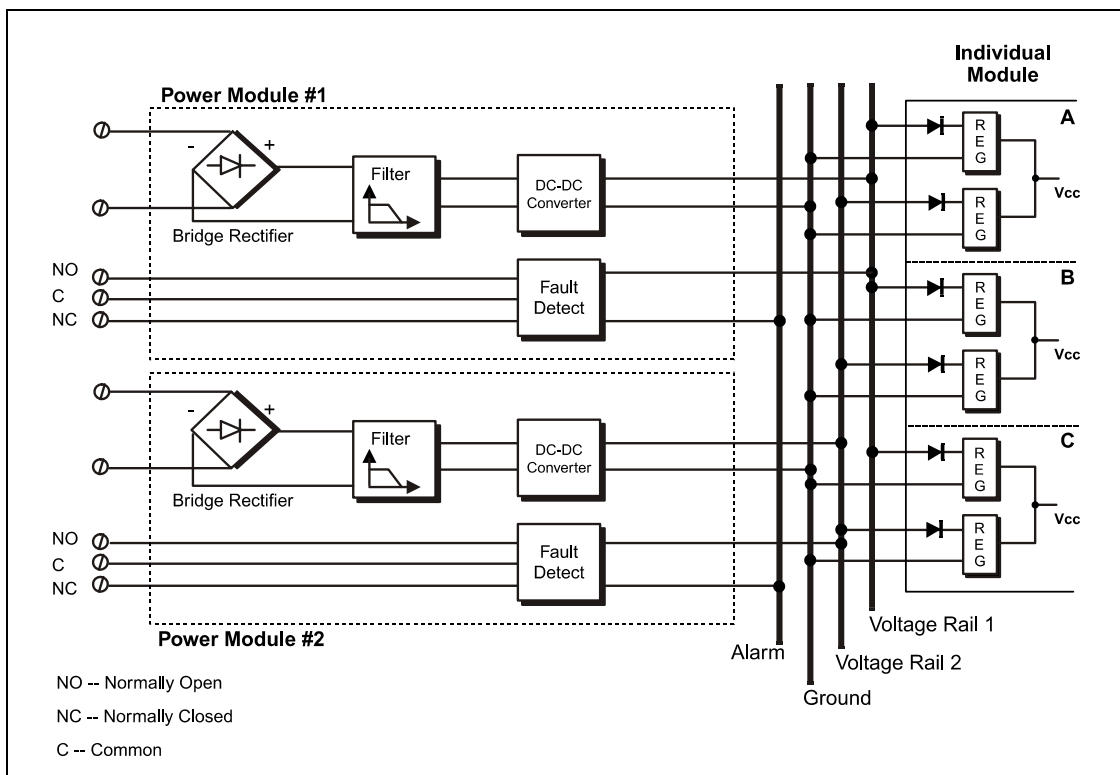

Architecture of Power Module Subsystem



*A Tricon system consists of one Main Chassis and up to fourteen additional chassis.*

## System Configuration

A Tricon system is composed of a Main Chassis and up to 14 Expansion or Remote Expansion (RXM) Chassis. The maximum system size is 15 chassis supporting a total of 118 I/O modules (maximum including spares), interface modules, and communication modules that interface with OPC clients, Modbus devices, other Tricon controllers, and external host applications on Ethernet (802.3) networks, as well as Foxboro and Honeywell distributed control systems (DCS).

The following sections provide guidelines for chassis layout and system configuration.

### Chassis Layout

Two power supplies reside on the left side of all chassis, one above the other. In the Main Chassis, the three Main Processors are immediately to the right. The remainder of the chassis is divided into six logical slots for I/O and communication modules and one COM slot with no hot-spare position. Each logical slot provides two physical spaces for modules, one for the active module and the other for its optional hot-spare module.

The layout of an Expansion Chassis is similar to that of the Main Chassis, except that Expansion Chassis provide eight logical slots for I/O modules. (The spaces used by the Main Processors and the COM slot in the Main Chassis are now available for other purposes.)

The Main and Expansion Chassis are interconnected by means of triplicated

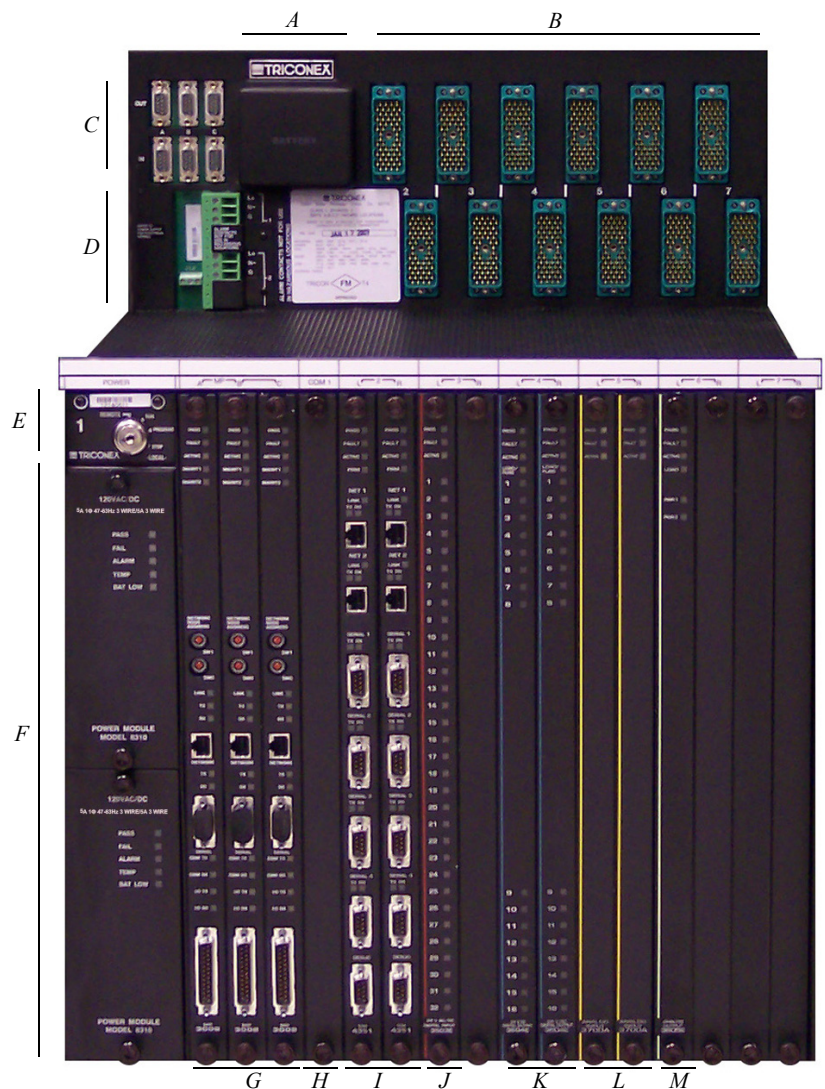

- |                                |                            |                             |
|--------------------------------|----------------------------|-----------------------------|
| A. Memory backup battery       | F. Redundant Power Modules | K. DO module with hot-spare |
| B. Connectors for terminations | G. Three Main Processors   | L. AI module with hot-spare |
| C. I/O expansion ports         | H. COM slot (empty)        | M. AO module without spare  |
| D. Power terminals             | I. Two TCMs                |                             |
| E. Keyswitch                   | J. DI module without spare |                             |

**Sample Layout of a Tricon Chassis**

# System Configuration

I/O bus cables. The maximum I/O bus cable length between the Main Chassis and the last Expansion Chassis is 100 feet (30 meters), but in restricted applications the length can be greater. (Please contact the Invensys Global Customer Support (GCS) center for assistance when configuring a system that exceeds 100 feet (30 meters) of I/O bus cable length.)

RXM Chassis are used for systems in which the total cable distance between the first chassis and the last chassis exceeds the distance which can be supported by copper. Each RXM Chassis houses a set of three RXM Modules in the same position as the Main Processors in the Main Chassis. Six remaining logical slots are available in an RXM Chassis and one blank (unused) slot.

## Online Module Repair

The logical slot arrangement of a Tricon chassis provides two approaches to the online repair of faulting modules: the *hot-spare* method and *online module replacement*.

With the hot-spare method, a logical slot contains two identical I/O modules. While one module is active, the other module is powered but inactive. The Tricon system cycles control between the two healthy I/O modules approximately every hour, so that each undergoes complete diagnostics on a regular basis. If a fault is detected on one module, the Tricon system automatically switches control to the other module, allowing the system to maintain three healthy channels continuously. The faulty module can then be removed and replaced.

Alternatively, a module can be replaced online even when only one I/O module is normally installed in a logical slot. If a fault occurs, the Fault indicator turns on, but the module remains active on two channels. A replacement module is then inserted into the unused space in the slot. The Tricon system will grant control to this second I/O module after it passes a diagnostic test. Once the replacement I/O module becomes active, the faulty module can be removed. This repair method demonstrates the Tricon controller's ability to

automatically transition from triplicated to dual control and back again without process interruption.

A Tricon system should include at least one hot-spare module in place for each type of I/O module in the system. With this arrangement, hot-spare modules are tested regularly and can be used for online module replacement anywhere in the system.

## I/O Bus Connections

The I/O Bus Ports figure shows the three sets of RS-485 I/O bus ports (IN and OUT) on each chassis. Additional chassis may branch out from the Main Chassis by means of the I/O bus ports, up to a maximum of 14. There are six ports—two sets of three for triplicated serial communication — located on a panel in the upper left corner of the backplane. One set of three I/O bus cables is required for each Expansion Chassis, and for each RXM Chassis that houses a primary RXM Module set. (Remote RXM Chassis are connected to the primary RXM Chassis with fiber-optic cables.) Communication across the I/O bus cables (and the RXM fiber-optic cables) is at 375 kilobits per second, the same rate as the internal I/O bus on the backplane of each chassis.

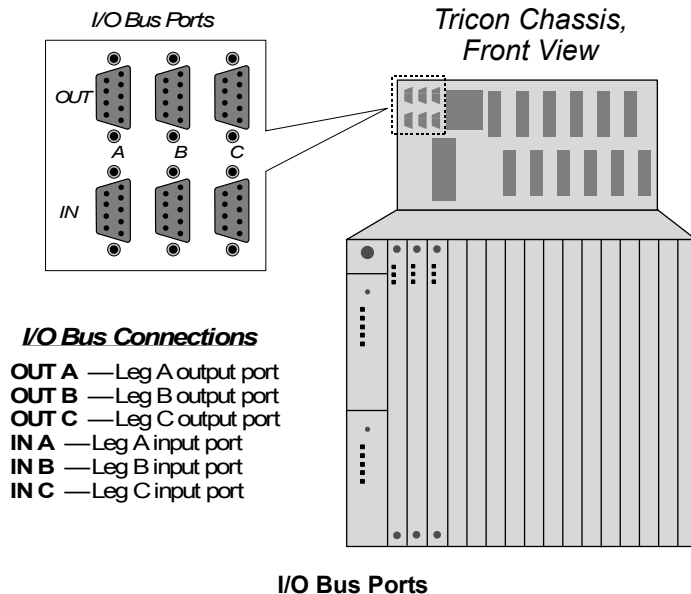

## System Configuration Guidelines

A Tricon system must have a Main Chassis, and may have up to 14 Expansion or Remote Expansion (RXM) Chassis. The following configuration guidelines apply.

### Main Chassis Configuration Guidelines

- There is one Main Chassis with a chassis address of 1.
- The Main Chassis must contain three Model 3008 Main Processors for Tricon v10 and later systems.
- The Main Chassis must house two Power Modules.
- The Main Chassis provides six logical slots for user-selected modules and one COM slot.
- A v10 low-density configuration includes a v5–v8 chassis with v10 Main Processors, communication, and I/O modules.

### Expansion Chassis Configuration Guidelines

- Expansion Chassis are used when the total I/O bus cable length for the system is less than 100 feet (30 meters) for each channel.
- Each Expansion Chassis must have a unique address between 2 and 15. This address must not be used by any other chassis.
- Each Expansion Chassis must house two Power Modules.
- One set of triplicated I/O bus cables is used to interconnect channels A, B, and C between Expansion Chassis.
- Each Expansion Chassis provides eight logical slots.

### RXM Chassis Configuration Guidelines

- RXM Chassis must be used when the total I/O bus cable length for the system is greater than 100 feet (30 meters) for each channel.
- Each RXM Chassis must have a unique address between 2 and 15. This address must not be used by any other chassis.
- One RXM Chassis must be located within 100 feet (30 meters) of the Main Chassis. This RXM Chassis must house the primary RXM Module set. Up to three primary RXM Module sets are normally

supported. Contact Invensys regarding other configurations.

- Each primary RXM Module set can support up to three remote sites, each up to 7.5 miles (12 kilometers) away.
- One RXM Chassis must be located at each remote site. This RXM Chassis must house a remote RXM Module set.
- A primary RXM Module set and a remote RXM Module set are connected by six fiber-optic cables which transmit and receive signals for channels A, B, and C.

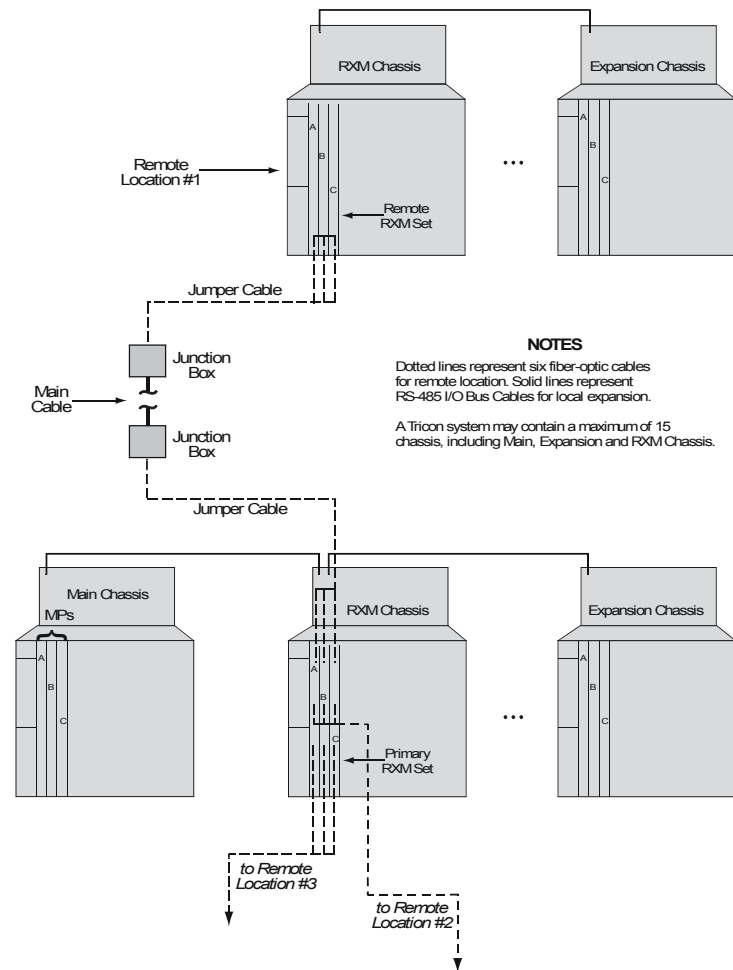

System Configuration with Three Remote Locations

## System Configuration

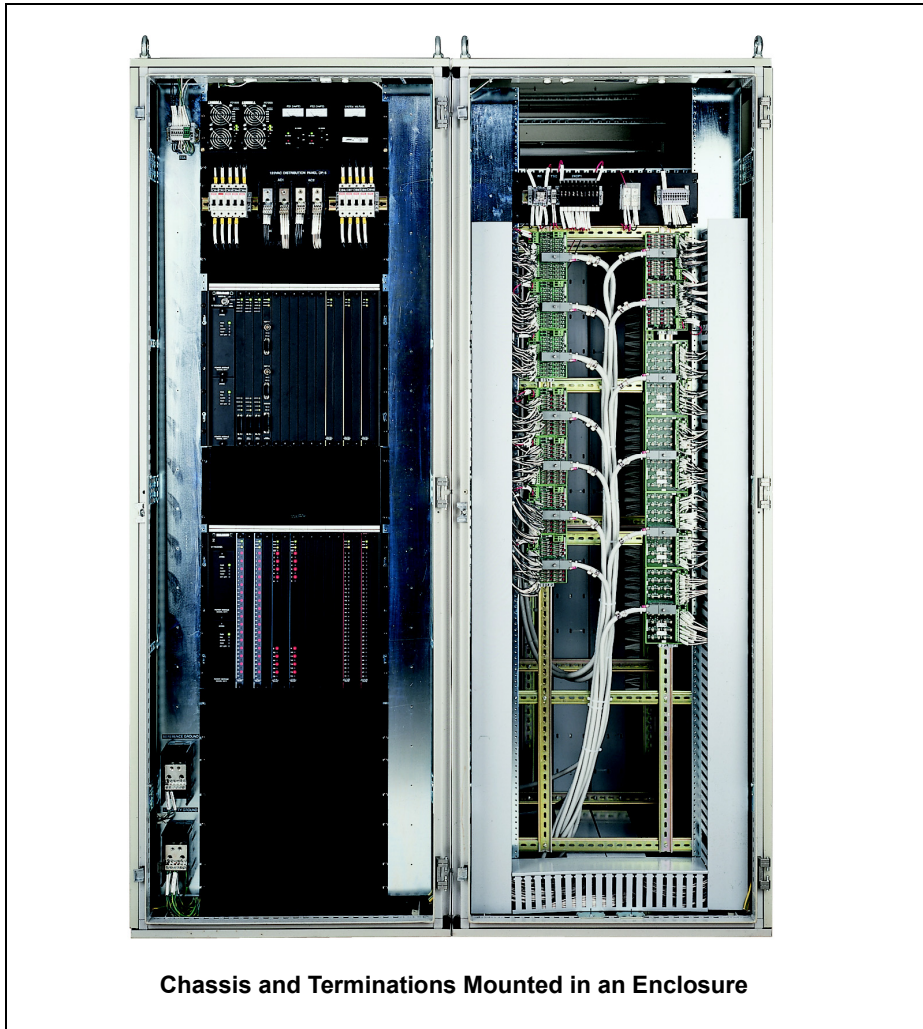

**Chassis and Terminations Mounted in an Enclosure**

- RXM Chassis can be connected to local Expansion Chassis using I/O bus cables.
- Each RXM Chassis must contain two Power Modules.
- Each RXM Chassis provides six logical slots for I/O modules and one blank (unused) slot.

### Communication Module Configuration Guidelines

The following rules apply to the TCM, EICM, NCM, HIM, SMM, and ACM in a Tricon system:

- A TriStation 1131 PC communicates with a Tricon controller through a TCM, EICM, NCM or ACM, so at least one of these modules must be installed in the Main Chassis or Chassis 2.
- One logical slot is available for EICMs or ACMs, respectively. Matched pairs of these modules can be installed in both the left and right positions of one logical slot.
- Up to two logical slots can be configured for NCMs. Matched pairs of NCMs can be installed in the left and right positions of each logical slot. If only one logical slot is used, the slot can be in the Main Chassis or Chassis 2. If two logical slots are used, they must be Slot 6 and 7 in the Main Chassis, and Peer-to-Peer cannot be used.
- Up to two logical slots can be configured for TCMs. Matched pairs of TCMs can be installed in the left and right positions of each logical slot, and they can be located in the Main Chassis or Chassis 2.

- Up to three logical slots can be configured for SMMs. A matched pair of SMMs can be installed in the left and right positions of each logical slot. All three slots must be in the Main Chassis or Chassis 2.
- Up to two logical slots can be configured for HIMs. Both slots must be in the Main Chassis.
- The COM slot can be configured only for the EICM, TCM, or NCM.
- You cannot install an NCM and a TCM in the same Tricon system. You also cannot install an EICM and a TCM in the same system.
- Model 4351A, 4351B, 4352A, and 4352B TCMs cannot be installed into a system with Model 4351 or 4352 TCMs, even if they are installed in different chassis.
- If communication modules are housed in Chassis 2, this chassis must be connected directly to the Main Chassis using I/O COMM cables (Model 9001) rather than standard I/O bus cables.
- Chassis 2 can be an I/O Expansion Chassis or a primary RXM Chassis.

**Chassis Power Limitations**

To maintain the safety and reliability of the Tricon controller, each system must be configured for operation under a worst-case scenario. These circumstances include operation with only one functional power supply at 140° F (60° C), ambient. (See “Power Modules” on page 32 for detailed specifications). Under these conditions, the power supply is rated to deliver 175 watts. The table to the right lists the logic power consumption per module in watts.

| Module Type                        | Watts Consumed |
|------------------------------------|----------------|
| ACM                                | 15             |
| Analog Input                       | 10             |
| Analog Input, Models 3720 and 3721 | 12             |
| Analog Input, Isolated             | 15             |
| Analog Input, High-Density         | 10             |
| Analog Output                      | 15             |
| Analog Output, Bipolar             | 20             |
| Digital Input, High-Density        | 10             |
| Digital Input, Single              | 10             |
| Digital Input, TMR                 | 10             |
| Digital Output, AC                 | 10             |
| Digital Output, DC                 | 10             |
| Digital Output, Dual               | 10             |
| Digital Output, Supervised         | 15             |
| EICM                               | 10             |
| HART Analog Input Interface        | 5              |
| HART Analog Output Interface       | 5              |
| HIM                                | 10             |
| Main Processor, Model 3008         | 10             |
| NCM                                | 20             |
| Power Module                       | n/a            |
| SMM                                | 20             |
| TCM                                | 7              |
| Thermocouple Input, Isolated       | 15             |
| Thermocouple Input, Non-Isolated   | 10             |
| Pulse Input                        | 20             |
| Pulse Totalizer                    | 10             |
| RXM                                | 5              |
| Relay Output                       | 15             |



*The Tricon controller supports a comprehensive range of modules to meet customers' needs.*

## Product Specifications

The Triconex product family includes a comprehensive range of modules. This section includes: a summary of the system components and their uses, a table that lists standard products and their model numbers, and a summary of specifications for each standard product in the Tricon controller family.

See the *Planning and Installation Guide for Tricon v9-v10 Systems* for complete information.

### Summary of Tricon System Components

#### Chassis

- *Main Chassis*—houses Main Processors, memory back-up batteries, communication modules and I/O modules.
- *Expansion Chassis*—for additional I/O modules with up to 100 feet (30 meters) total cable length between the Main Chassis and the last Expansion Chassis.
- *RXM Chassis*—for I/O modules up to 7.5 miles (12 kilometers) away from the Main Chassis.
- *Mechanical Keying*—Each slot in the Tricon controller is mechanically keyed to correspond with a specific type of module. This prevents the installation of modules into improper slots.

For chassis mounting and enclosure specifications, see page 31.

#### Power Supply Modules

- Provide logic power to modules in the Main, Expansion or RXM Chassis. Available in 24 VDC, 115 VAC and 230 VAC versions. The power rating of each power supply is 175 watts at 140° F (60° C).

#### Main Processors

The Main Processors execute the system diagnostics and the user-written control program.

#### Communication Modules

- *Tricon Communication Modules (TCM)* support a number of Triconex protocols and applications and user-written applications on Ethernet (802.3) networks, including TriStation, Modbus TCP, and OPC. It also supports RS-232 and RS-485 serial communication with Modbus devices, TriStation 1131, and GPS for time synchronization.
- *Enhanced Intelligent Communication Modules (EICM)* support RS-232, RS-422 and RS-485 serial communication with Modbus devices and TriStation 1131 applications.
- *Network Communication Modules (NCM)* support a number of Triconex protocols and applications and user-written applications on Ethernet (802.3) networks, including the TriStation 1131 software.
- *Safety Manager Modules (SMM)* act as an interface between a Tricon controller and a Honeywell Universal Control Network (UCN), one of three principal networks of the TDC-3000 DCS.
- *Hiway Interface Modules (HIM)* act as an interface between a Tricon controller and a Honeywell TDC-3000 Hiway Gateway and Local Control Network (LCN).
- *Advanced Communication Modules (ACM)* allow a Tricon controller to interface with a Foxboro Industrial

Automation (I/A) Series DCS and a TriStation 1131 application.

#### Fiber-Optic Remote Extender Modules (RXM)

For operation of Expansion Chassis up to 7.5 miles (12 kilometers) away from the Main Chassis, with exceptional immunity against electro-static and electro-magnetic interference.

#### Interface Modules

- *HART Analog Input Interface Modules* act as an interface between 4-20 mA analog input points from HART smart devices in the field and HART Host software running on a PC.
- *HART Analog Output Interface Modules* act as an interface between 4-20 mA analog output points from HART smart devices in the field and HART Host software running on a PC.

#### I/O Modules

- *Digital Input Modules* receive discrete signals of these nominal voltages: 115 VAC/VDC, 48 VAC/VDC, and 24 VAC/VDC. All voltages are available in TMR modules. Non-TMR modules are available in 24 VDC and 48 VDC only. Speed input and totalization modules are also available.
- *Supervised Digital Output Modules* produce discrete output signals of these nominal voltages, with diagnostic coverage of the field circuit and load device: 115 VAC, 120 VDC, 48 VDC, and 24 VDC.
- *Digital Output Modules* produce discrete output signals of these nominal voltages: 115 VAC, 120

## Product Specifications

---

VDC, 24 VDC, and 48 VDC. Dual output modules are also available.

- *Analog Input Modules* receive analog signals of these types: 0-5 VDC, -5 to +5 VDC, 0-10 VDC, and Thermocouple types J, K, T and E. Available in both isolated and DC-coupled versions.
- *Analog Output Modules* are available in these versions: eight output points at 4-20 mA; six output points at 4-20 mA and two at 20-320 mA; and four output points at -60 to 60 mA.

### Conformal Coating

Most of the Tricon hardware models in the *Planning and Installation Guide for Tricon v9-v10 Systems* and the *Field Terminations Guide for Tricon v9-v10 Systems* can be ordered with conformal coating by adding the letter “C” to the end of the standard model number.

The following equipment *cannot* be ordered with conformal coating:

- Equipment certified for use in nuclear 1E applications
- All types of cables; including interface cables, I/O bus cables, and fanned-out cables

- Blank slot covers

Neoprene dust covers are provided with external termination panels and chassis that are conformal coated. You can install the dust covers on unused external termination panel connectors and unused backplane connectors, at your discretion.

*Some* of the Tricon hardware with conformal coating has been certified for use in marine environments. For more information, see “Tricon Equipment Certified for Use in Marine Environments” on page 21.

## Standard Tricon System Products

| Description   | Model No.                                   | See              |
|---|---|------------------|
| <b>Chassis Assemblies</b>   |   |                  |
| Main Chassis, High-Density Configuration, includes the Tricon printed manuals             | 8110  | page 13, page 29 |
| Expansion Chassis, High-Density Configuration   | 8111  | page 13, page 29 |
| Expansion Chassis, Enhanced Low-Density Configuration                                     | 8121  | page 13, page 29 |
| Remote Expansion Chassis, High-Density Configuration                                      | 8112  | page 13, page 29 |
| I/O Bus Expansion Cables (Set of 3)   | 9000 <sup>a</sup>                           | page 12          |
| I/O-COMM Bus Expansion Cables (Set of 3)  | 9001  | page 12, page 29 |
| Blank I/O Slot Panel  | 8105  | page 30          |
| <b>Power Modules</b>  |   |                  |
| 120 VAC/VDC – 175-Watt Power Module   | 8310  | page 32          |
| 24 VDC – 175-Watt Power Module  | 8311  | page 32          |
| 230 VAC – 175-Watt Power Module   | 8312  | page 32          |
| <b>Main Processor Modules</b>   |   |                  |
| 3008 Main Processor, 16 megabytes DRAM  | 3008  | page 33          |
| <b>Communication Hardware and Software</b>  |   |                  |
| Tricon Communication Module (TCM), Ethernet (802.3) and serial (RS-232/RS-485) ports      | 4351A, 4352A,<br>4351B, 4352B<br>4353, 4354 | page 34          |
| Enhanced Intelligent Communication Module (EICM), serial (RS-232/RS-422/RS-485) ports     | 4119, 4119A                                 | page 35          |
| Safety Manager Module (SMM), Honeywell UCN Interface                                      | 4409  | page 36          |
| Network Communication Module (NCM), Ethernet (802.3) ports                                | 4329, 4329G                                 | page 37          |
| Advanced Communication Module (ACM), Foxboro I/A Series Nodebus Interface                 | 4609  | page 38          |
| Hiway Interface Module (HIM), Honeywell Data Hiway Interface                              | 4509  | page 39          |
| Triconex DDE Server Software  | Contact Invensys                            | page 69          |
| Network Accessory Kit (Ethernet thin cable, connectors and terminators)                   | 7600-3                                      | n/a              |
| <b>Remote Extender Modules</b>  |   |                  |
| Primary RXM, Multi-Mode Fiber Optics, Set of 3 Modules                                    | 4200-3                                      | page 40          |
| Remote RXM, Multi-Mode Fiber Optics, Set of 3 Modules                                     | 4201-3                                      | page 40          |
| Primary SRXM, Single-Mode Fiber Optics, Set of 3 Modules                                  | 4210-3                                      | page 40          |
| Remote SRXM, Single-Mode Fiber Optics, Set of 3 Modules                                   | 4211-3                                      | page 40          |
| <b>Interface Modules</b>  |   |                  |
| HART Analog Input Interface Module with 2071H HART Multiplexer                            | 2770H                                       | page 54          |
| HART Analog Input Interface Module with 2071H HART Multiplexer and Amp-Elco Adapter Cable | 2750-2H                                     | page 54          |
| HART Analog Output Interface Module with 2071H HART Multiplexer                           | 2870H                                       | page 54          |
| HART Multiplexer  | 2071H                                       | page 54          |
| <b>TriStation 1131 and Diagnostic Software</b>  |   |                  |
| TriStation 1131 v4.x Software License with printed manuals                                | Contact Invensys                            | page 71          |
| Enhanced Diagnostic Monitor v2.x  | Contact Invensys                            | page 72          |

## Product Specifications

| Description  | Model No.        | See |
|--|------------------|-----|
| <b>Documentation Sets</b>  |                  |     |
| Tricon <i>Planning and Installation</i> , <i>Field Terminations</i> , and <i>Communication</i> printed manuals | Contact Invensys |     |
| Triconex User Documentation, includes all manuals in PDF format (CD-ROM)                                       | Contact Invensys |     |

a. I/O Bus Expansion Cables are available in custom lengths. Please contact Invensys for more information.

### Tricon I/O Modules

| Voltage                       | Description  | Type            | Model No.             | Points | For Details, See |
|-------------------------------|--|-----------------|-----------------------|--------|------------------|
| <b>Digital Input Modules</b>  |  |                 |                       |        |                  |
| 115 VAC/VDC                   | Opto-Isolated, Non-Commoned                            | TMR             | 3501E/3501T           | 32     | page 41          |
| 48 VAC/VDC                    | Commoned in Groups of 8, Self-Test                     | TMR             | 3502E                 | 32     | page 41          |
| 24 VAC/VDC                    | Commoned in Groups of 8, Self-Test                     | TMR             | 3503E                 | 32     | page 41          |
| 24/48 VDC                     | High-Density, DC Coupled                               | TMR             | 3504E                 | 64     | page 42          |
| 24 VDC                        | Low Threshold with Self-test, Commoned                 | TMR             | 3505E                 | 32     | page 41          |
| 24 VDC                        | Single, Opto-Isolated, Commoned                        | Single          | 3564                  | 64     | page 42          |
| Pulse Input                   | Differential, AC Coupled                               | TMR             | 3511                  | 8      | page 43          |
| Pulse Totalizer               | Opto-isolated, Non-commoned                            | TMR             | 3515                  | 32     | page 44          |
| <b>Digital Output Modules</b> |  |                 |                       |        |                  |
| 115 VAC                       | Opto-Isolated, Non-commoned                            | TMR             | 3601E/3601T           | 16     | page 45          |
| 120 VDC                       | Opto-Isolated, Non-commoned<br>Opto-Isolated, Commoned | TMR             | 3603B,<br>3603E/3603T | 16     | page 45          |
| 24 VDC                        | Opto-Isolated, Non-commoned                            | TMR             | 3604E                 | 16     | page 45          |
| 48 VDC                        | Opto-Isolated, Non-commoned                            | TMR             | 3607E                 | 16     | page 45          |
| 115 VAC                       | Galvanically Isolated, Commoned., Supv.                | TMR             | 3611E                 | 8      | page 47          |
| 48 VDC                        | Galvanically Isolated, Commoned, Supv.                 | TMR             | 3617E                 | 8      | page 47          |
| 120 VDC                       | Opto-Isolated, Commoned, Supervised                    | TMR             | 3623/3623T            | 16     | page 46          |
| 24 VDC                        | Opto-Isolated, Commoned, Supervised                    | TMR             | 3624                  | 16     | page 46          |
| 24 VDC                        | Supervised/Non-Supervised, Commoned                    | TMR             | 3625/3625A            | 32     | page 46          |
| 24 VDC                        | Opto-Isolated, Commoned                                | Dual            | 3664                  | 32     | page 48          |
| 24 VDC                        | Opto-Isolated, Commoned                                | Dual            | 3674                  | 32     | page 48          |
| Relay Output                  | Non-triplicated, Normally Open                         | Non-triplicated | 3636R/3636T           | 32     | page 43          |
| <b>Analog Input Modules</b>   |  |                 |                       |        |                  |
| 0-5 VDC                       | Differential, DC Coupled                               | TMR             | 3700A                 | 32     | page 49          |
| 0-10 VDC                      | Differential, DC Coupled                               | TMR             | 3701                  | 32     | page 49          |
| 0-5, 0-10 VDC                 | Differential, Isolated                                 | TMR             | 3703E                 | 16     | page 49          |
| 0-5, 0-10 VDC                 | High-Density, Differential, DC Coupled                 | TMR             | 3704E                 | 64     | page 49          |
| Thermocouple                  | Differential, DC Coupled                               | TMR             | 3706A                 | 32     | page 52          |
| Thermocouple                  | Differential, Isolated                                 | TMR             | 3708E                 | 16     | page 52          |

| Voltage                      | Description                          | Type | Model No.   | Points  | For Details, See |
|------------------------------|--------------------------------------|------|-------------|---------|------------------|
| 0–5 VDC                      | Single-Ended                         | TMR  | 3720        | 64      | page 49          |
| 0 to 5 or –5 to +5 VDC       | Differential, DC Coupled             | TMR  | 3721        | 32      | page 49          |
| <b>Analog Output Modules</b> |                                      |      |             |         |                  |
| 4-20 mA                      | Current Loop, DC Coupled             | TMR  | 3805E/3805H | 8       | page 50          |
| 4-20 mA and 20-320 mA        | Current Loop, DC Coupled             | TMR  | 3806E       | 6 and 2 | page 50          |
| –60 to 60 mA                 | Bipolar, Commoned Return, DC Coupled | TMR  | 3807        | 4       | page 50          |

## Tricon Equipment Certified for Use in Marine Environments

Bureau Veritas (BV) has certified specific Tricon products as being in full compliance with the following internationally recognized standard and qualified for use in marine environments:

BV NR467:2011, Part C, Ch 2-3 Rules for the Classification of Steel Ships; Part C - Machinery, Electricity, Automation and Fire Protection; Chapters 2-3

Bureau Veritas Environmental Category, EC Code: 31C

The following table lists the model numbers of Tricon equipment certified for use in marine environments and identifies the standard model to see for information about the equipment. All of the information (specifications, simplified schematics, installation guidelines, and so on) for standard equipment also applies to marine equipment. Additionally, refer to the *Planning and Installation Guide for Tricon v9–v10 Systems* for application-specific installation instructions.

| Model Number                           | Description   | See This Standard Model |
|--|---|-------------------------|
| <b>Modules and Chassis<sup>a</sup></b> |   |                         |
| 8110C                                  | Main Chassis  | 8110                    |
| 8111C                                  | Expansion Chassis   | 8111                    |
| 8112C                                  | Remote Expansion Chassis  | 8112                    |
| 8310C                                  | High-Density Power Module, 120 V                                    | 8310                    |
| 8311C                                  | High-Density Power Module, 24 VDC                                   | 8311                    |
| 8312C                                  | High-Density Power Module, 230 VAC                                  | 8312                    |
| 3008C                                  | Enhanced Main Processor III, 16 Mb                                  | 3008                    |
| 4200C                                  | Remote Extender Module  | 4200                    |
| 4200-3C                                | Remote Extender Module (Set)  | 4200-3                  |
| 4201C                                  | Remote Extender Module  | 4201                    |
| 4201-3C                                | Remote Extender Module (Set)  | 4201-3                  |
| 4351BC                                 | Tricon Communication Module (TCM), copper                           | 4351B                   |
| 4352BC                                 | Tricon Communication Module (TCM), fiber-optic                      | 4352B                   |
| 4353C                                  | Tricon Communication Module (TCM), Embedded OPC Server, copper      | 4353                    |
| 4354C                                  | Tricon Communication Module (TCM), Embedded OPC Server, fiber-optic | 4354                    |
| 3703EC                                 | AI, 0–5 VDC or 0–10 VDC, differential, isolated, TMR, 16 pts.       | 3703E                   |
| 3721C                                  | AI, 0–5 VDC or –5 to +5 VDC, differential, DC-coupled, TMR, 32 pts. | 3721                    |
| 3700AC                                 | AI, 0–5 VDC, non-commoned, differential, DC-coupled, TMR, 32 pts.   | 3700A                   |
| 3720C                                  | AI, 0–5 VDC, single-ended, 64 pts.                                  | 3720                    |

## Product Specifications

| Model Number  | Description   | See This Standard Model |
|---|---|-------------------------|
| 3805HC  | AO, 4–20 mA, current loop, DC-coupled, TMR, 8 pts.                        | 3805H                   |
| 3505EC  | DI, 24 VDC, low threshold, 32 pts.  | 3505E                   |
| 3503EC  | DI, 24 VAC/VDC, commoned in groups of 8, self-test, TMR, 32 pts.          | 3503E                   |
| 3564C   | DI, 0–5 VDC, single-ended, high-density, TMR, 64 pts.                     | 3564                    |
| 3664C   | DO, 24 VDC, commoned, opto-isolated, self-protected, dual, 32 pts.        | 3664                    |
| 3625C   | DO, 24 VDC, supervised/non-supervised, commoned, TMR, 32 pts.             | 3625                    |
| 3625AC  | DO, 24 VDC, supervised/non-supervised, commoned, TMR, 32 pts.             | 3625A                   |
| 3511C   | Pulse Input, differential, AC-coupled, TMR, 8 pts.                        | 3511                    |
| 3636TC  | Relay Output, normally open, non-triplicated, 32 pts.                     | 3636T                   |
| <b>External Termination Panels and FT4 Interface Cables<sup>b</sup></b> |   |                         |
| 9563-810FC  | Term panel with cable 4000187-310; for use with 3503EC and 3505EC         | 9563-810F               |
| 9566-710FC  | Term panel with cable 4000187-310; for use with 3564C                     | 9566-710F               |
| 9662-610FC  | Term panel with cable 4000188-310; for use with 3625C, 3625AC, and 3664C  | 9662-610F               |
| 9668-110FC  | Term panel with cable 4000188-110 <sup>c</sup> ; for use with 3636TC      | 9668-110F               |
| 9753-110FC  | Term panel with cable 4000189-510; for use with 3511C                     | 9753-110F               |
| 9765-210FC  | Term panel with cable 4000206-510; for use with 3720C                     | 9765-210F               |
| 9771-210FC  | Term panel with cable 4000189-510; for use with 3700AC, 3703EC, and 3721C | 9771-210F               |
| 9853-610FC  | Term panel with cable 4000190-510; for use with 3805HC                    | 9853-610F               |

a. For information about modules and chassis, see the *Planning and Installation Guide for Tricon v9–v10 Systems*.

b. For information about external termination panels and interface cables, see the *Field Terminations Guide for Tricon v9–v10 Systems*.

c. A low smoke zero halogen (LSZH) cable is also certified for use with the external termination assembly (ETA) that is included with model 9668-110FC. If you need the LSZH cable, order ETA 3000590-110C and LSZH cable 4000141-110, separately.

## Tricon v10.x Equipment Certified for Use in Nuclear 1E Applications

Invensys has qualified specific Tricon version 10 products for use in 1E (safety-related) applications in nuclear power plants in accordance with EPRI Report TR-107330, “Generic Requirements Specification for Qualifying Commercially Available PLC for Safety-Related Applications in Nuclear Power Plants.” EMC testing was performed in accordance with USNRC Regulatory Guide 1.180, Revision 1, “Guidelines for Evaluating Electromagnetic and Radio-Frequency Interference in Safety-Related Instrumentation and Control Systems.”

All of the information (specifications, simplified schematics, installation guidelines, and so on) for standard equipment also applies to nuclear equipment. The following table lists the model numbers of Tricon v10.x equipment certified for use in Nuclear 1E applications and identifies the standard model to see for information about the equipment.

| Model Number               | Description  | See This Standard Model |
|----------------------------|--|-------------------------|
| <b>Modules<sup>a</sup></b> |  |                         |
| 8110N2                     | Main Chassis   | 8110                    |
| 8111N                      | Expansion Chassis                                      | 8111                    |
| 8112N                      | Remote Expansion Chassis                               | 8112                    |
| 8310N2                     | High-Density Power Module, 120 V                       | 8310                    |
| 8311N2                     | High-Density Power Module, 24 VDC                      | 8331                    |
| 8312N2                     | High-Density Power Module, 230 VAC                     | 8312                    |
| 3008N                      | Enhanced Main Processor III, 16 Mb                     | 3008                    |
| 4200N                      | Remote Extender Module                                 | 4200                    |
| 4200-3N                    | Remote Extender Module (Set)                           | 4200-3                  |
| 4201N                      | Remote Extender Module                                 | 4201                    |
| 4201-3N                    | Remote Extender Module (Set)                           | 4201-3                  |
| 4352AN                     | Tricon Communication Module (TCM)                      | 4352A                   |
| 4352BN                     | Tricon Communication Module (TCM)                      | 4352B                   |
| 3701N2                     | 0–10 VDC, Differential DC Coupled, TMR                 | 3701                    |
| 3703EN                     | 0–5 VDC or 0–10 VDC, Differential, Isolated, TMR       | 3703E                   |
| 3721N                      | 0–5 VDC or –5 to +5 VDC, Differential, DC Coupled, TMR | 3721                    |
| 3805HN                     | 4–20 mA, Current Loop, DC Coupled, TMR                 | 3805H                   |
| 3501TN2                    | 115 VAC, Opto-isolated, Non-commoned, TMR              | 3501T                   |
| 3502EN2                    | 48 VAC/VDC, Commoned in Groups of 8, Self-Test, TMR    | 3502E                   |
| 3503EN2                    | 24 VAC/VDC, Commoned in Groups of 8, Self-Test, TMR    | 3503E                   |
| 3601TN                     | 115 VAC, Opto-isolated, Non-commoned, TMR              | 3601T                   |
| 3603TN                     | 120 VDC, Opto-isolated, Commoned, TMR                  | 3603T                   |
| 3607EN                     | 48 VDC, Opto-isolated, Non-commoned, TMR               | 3607                    |
| 3623TN                     | 120 VDC, Opto-isolated, Commoned, Supervised, TMR      | 3623T                   |
| 3625N                      | 24 VDC, Supervised/Non-supervised, Commoned, TMR       | 3625                    |
| 3511N                      | Pulse Input, Differential, AC Coupled, TMR             | 3511                    |
| 3708EN                     | Thermocouple, Differential, Isolated, TMR              | 3708                    |
| 3636TN                     | Relay Output, Normally Open, Non-triplicated           | 3636T                   |
| 8105N                      | Blank Module Panel                                     | 8105                    |

## Product Specifications

| Model Number   | Description   | See This Standard Model |
|--|---|-------------------------|
| <b>External Termination Panels with XLPE I/F Cables<sup>b</sup></b>  |   |                         |
| 9561-110N  | Term Panel (3501TN2) with XLPE Cable                                    | 9561-110F               |
| 9561-810N  | Term Panel (3501TN2) with XLPE Cable                                    | 9561-810F               |
| 9562-810N  | Term Panel (3502EN2) with XLPE Cable                                    | 9562-810F               |
| 9563-810N  | Term Panel (3503EN2) with XLPE Cable                                    | 9563-810F               |
| 9662-610N  | Term Panel (3625N) with XLPE Cable                                      | 9662-610F               |
| 9662-810N  | Term Panel (3625N) with XLPE Cable                                      | 9662-810F               |
| 9663-610N  | Term Panel (3601TN) with XLPE Cable                                     | 9663-610F               |
| 9664-810N  | Term Panel (3603TN, 3623TN) with XLPE Cable                             | 9664-810F               |
| 9667-810N  | Term Panel (3607EN) with XLPE Cable                                     | 9667-810F               |
| 9668-110N  | Term Panel (3636TN) with XLPE Cable                                     | 9668-110F               |
| 9764-310N  | Term Panel (3721N) with XLPE Cable                                      | 9764-310F               |
| 9782-110N  | Term Panel (3708EN) with XLPE Cable                                     | 9782-110F               |
| 9783-110N  | Term Panel (3721N, 3703EN, 3701N2) with XLPE Cable                      | 9783-110F               |
| 9790-610N  | Term Panel (3721N, 3703EN) with XLPE Cable                              | 9790-610F               |
| 9792-610N  | Term Panel (16–56 V Analog Input, 4–20 mA Nuclear EMC) with XLPE Cable  | 9792-610F               |
| 9794-110N  | Term Panel (3511N) with XLPE Cable                                      | 9794-110F               |
| 9795-610N  | Term Panel (3701N2) with XLPE Cable                                     | 9795-610F               |
| 9860-610N  | Term Panel (3805HN) with XLPE Cable                                     | 9860-610F               |
| <b>External Termination Panels with XLPEJ I/F Cables<sup>b</sup></b> |   |                         |
| 9561-110NJ   | Term Panel (3501TN2) with XLPEJ Cable                                   | 9561-110F               |
| 9561-810NJ   | Term Panel (3501TN2) with XLPEJ Cable                                   | 9561-810F               |
| 9562-810NJ   | Term Panel (3502EN2) with XLPEJ Cable                                   | 9562-810F               |
| 9563-810NJ   | Term Panel (3503EN2) with XLPEJ Cable                                   | 9563-810F               |
| 9662-610NJ   | Term Panel (3625N) with XLPEJ Cable                                     | 9662-610F               |
| 9662-810NJ   | Term Panel (3625N) with XLPEJ Cable                                     | 9662-810F               |
| 9663-610NJ   | Term Panel (3601TN) with XLPEJ Cable                                    | 9663-610F               |
| 9664-810NJ   | Term Panel (3603TN, 3623TN) with XLPEJ Cable                            | 9664-810F               |
| 9667-810NJ   | Term Panel (3607EN) with XLPEJ Cable                                    | 9667-810F               |
| 9668-110NJ   | Term Panel (3636TN) with XLPEJ Cable                                    | 9668-110F               |
| 9764-310NJ   | Term Panel (3721N) with XLPEJ Cable                                     | 9764-310F               |
| 9782-110NJ   | Term Panel (3708EN) with XLPEJ Cable                                    | 9782-110F               |
| 9783-110NJ   | Term Panel (3721N, 3703EN, 3701N2) with XLPEJ Cable                     | 9783-110F               |
| 9790-610NJ   | Term Panel (3721N, 3703EN) with XLPEJ Cable                             | 9790-610F               |
| 9792-610NJ   | Term Panel (16–56 V Analog Input, 4–20 mA Nuclear EMC) with XLPEJ Cable | 9792-610F               |
| 9794-110NJ   | Term Panel (3511N) with XLPEJ Cable                                     | 9794-110F               |
| 9795-610NJ   | Term Panel (3701N2) with XLPEJ Cable                                    | 9795-610F               |
| 9860-610NJ   | Term Panel (3805HN) with XLPEJ Cable                                    | 9860-610F               |

| Model Number   | Description   | See This Standard Model |
|--|---|-------------------------|
| <b>External Termination Panels with PVC I/F Cables<sup>b</sup></b> |   |                         |
| 9561-110N-P  | Term Panel (3501TN2) with PVC Cable                                   | 9561-110F               |
| 9561-810N-P  | Term Panel (3501TN2) with PVC Cable                                   | 9561-810F               |
| 9562-810N-P  | Term Panel (3502EN2) with PVC Cable                                   | 9562-810F               |
| 9563-810N-P  | Term Panel (3503EN2) with PVC Cable                                   | 9563-810F               |
| 9662-610N-P  | Term Panel (3625N) with PVC Cable                                     | 9662-610F               |
| 9662-810N-P  | Term Panel (3625N) with PVC Cable                                     | 9662-810F               |
| 9663-610N-P  | Term Panel (3601TN) with PVC Cable                                    | 9663-610F               |
| 9664-810N-P  | Term Panel (3603TN, 3623TN) with PVC Cable                            | 9664-810F               |
| 9667-810N-P  | Term Panel (3607EN) with PVC Cable                                    | 9667-810F               |
| 9668-110N-P  | Term Panel (3636TN) with PVC Cable                                    | 9668-110F               |
| 9764-310N-P  | Term Panel (3721N) with PVC Cable                                     | 9764-310F               |
| 9782-110N-P  | Term Panel (3708EN) with PVC Cable                                    | 9782-110F               |
| 9783-110N-P  | Term Panel (3721N, 3703N, 3701N) with PVC Cable                       | 9783-110F               |
| 9790-610N-P  | Term Panel (3721N, 3703N)   | 9790-610F               |
| 9792-610N-P  | Term Panel (16–56 V Analog Input, 4–20 mA Nuclear EMC) with PVC Cable | 9792-610F               |
| 9794-110N-P  | Term Panel (3511N) with PVC Cable                                     | 9794-110F               |
| 9795-610N-P  | Term Panel (3701N2) with PVC Cable                                    | 9795-610F               |
| 9860-610N-P  | Term Panel (3805HN) with PVC Cable                                    | 9860-610F               |
| <b>Tricon I/O Cable Sets<sup>c</sup></b>                           |   |                         |
| 9000N  | I/O Bus Cable Set with XLPE Cable                                     | 9000                    |
| 9001N  | I/O and Comm Bus Cable Set with XLPE Cable                            | 9001                    |
| 9000NJ   | I/O Bus Cable Set with XLPEJ Cable                                    | 9000                    |
| 9001NJ   | I/O and Comm Bus Cable Set with XLPEJ Cable                           | 9001                    |
| 9000N-P  | I/O Bus Cable Set with PVC Cable                                      | 9000                    |
| 9001N-P  | I/O and Comm Bus Cable Set with PVC Cable                             | 9001                    |
| <b>Signal Conditioners<sup>d</sup></b>                             |   |                         |
| 1600024-010N   | Signal Conditioner (-100° C to 100° C) Pt                             | 1600024-010             |
| 1600024-020N   | Signal Conditioner (0° C to 100° C) Pt                                | 1600024-020             |
| 1600024-030N   | Signal Conditioner (0° C to +200° C) Pt                               | 1600021-030             |
| 1600024-040N   | Signal Conditioner (0° C to +600°) Pt                                 | 1600024-040             |
| 1600081-001N   | Signal Conditioner (0° C to 120° C) Cu                                | 1600081-001             |
| 1600082-001N   | Signal Conditioner (0 to 100 mV) Pt                                   | 1600082-001             |
| 1600083-200N   | Signal Conditioner (0° C to 200° C) Pt                                | Contact Invensys        |
| 1600083-600N   | Signal Conditioner (0° C to 600° C) Pt                                | Contact Invensys        |

## Product Specifications

| Model Number  | Description  | See This Standard Model |
|---|--|-------------------------|
| <b>External Termination Assembly (ETA) Mounting Plates (Blank Panels)</b> |  |                         |
| 9420017-010N  | ETA Blank Panel 1.75 inches  | Contact Invensys        |
| 9420017-030N  | ETA Blank Panel 3.5 inches   | Contact Invensys        |
| 9420017-050N  | ETA Blank Panel 5.25 inches  | Contact Invensys        |
| 9420017-070N  | ETA Blank Panel 7 inches   | Contact Invensys        |
| <b>Chassis Mounting Bracket Kits</b>                                      |  |                         |
| 8405N   | Auxiliary Chassis Mounting Bracket Assembly Kit (Auxiliary/Rear Bracket) | 8405                    |

- a. For information about modules, see the *Planning and Installation Guide for Tricon v9–v10 Systems*.
- b. For information about external termination panels, see the *Field Terminations Guide for Tricon v9–v10 Systems*.
- c. The maximum length for cable models 9001N, 9001NJ, and 9001N-P is 6 feet.
- d. For information about signal conditioners, see the *Field Terminations Guide for Tricon v9–v10 Systems*.

## General Environmental and EMC Specifications

Other than the optional conformal coating of all PCB assemblies, the Tricon controller is not explicitly protected against dust or falling debris. Atmospheric and airborne-particle protection must be provided by housing the Tricon controller in an appropriate NEMA-rated enclosure.

|                                      |   |
|--------------------------------------|---|
| Operating Temperature                | 32° to 140° F (0° to 60° C), ambient, as measured at the bottom of the chassis, per IEC 60068-2-1 Test Nb   |
| Storage Temperature                  | -40° to 167° F (-40° to 75° C), per IEC 60068-2-14, Test Na   |
| Relative Humidity                    | 5% to 95%, non-condensing, per IEC 60068-2-2, Test Bb, and IEC 60068-2-3 test Db  |
| Corrosive Environment                | Class G3 Level as defined in ISA Standard S71.04, based on exposure testing according to EIA Standard 364-65A, Class IIIA   |
| Sinusoidal Vibrations per Axis       | 2 G @ 10 to 150 Hz, per IEC 60068-2-6, Test Fc  |
| Shock                                | 15 G for 6-11 ms in each axis, per IEC 60068-2-27   |
| Electrostatic Discharge              | IEC 61000-4-2, 8 kV air, 4 kV contact   |
| Conducted Susceptibility             | IEC 61000-4-4, Fast Transient/Burst, 2 kV power, 1 kV signal lines and<br>IEC 61000-4-5, Surge Withstand, 2 kV CM AC power lines, etc.<br>IEC 61000-4-6, RFI, 0.15-80 MHz, 10V  |
| Radiated Susceptibility              | IEC 61000-4-3, 26-1000 MHz, 10 V/m and IEC 61000-4-8, 50-60 Hz, 30 A/m  |
| Conducted Emissions                  | CISPR 16, Class A, 0.15-30 MHz, 73-79 db when installed per the guidelines of the <i>P&amp;I Guide</i>  |
| Radiated Emissions                   | CISPR 11, Class A, 30-1000 MHz @ 10 m, 4-47 db when installed per the guidelines of the <i>P&amp;I Guide</i>  |
| Cable Flame Test Rating <sup>a</sup> | <p><b>Interface cables</b><br/>(connect external termination panels to I/O modules):<br/>FT4 Vertical Flame Test-Cables in Cable Trays per C.S.A. C22.2 No. 0.3-92 Para 4.11.4<sup>b</sup></p> <p><b>I/O bus cables</b><br/>(connect chassis):<br/>FT6 Horizontal Flame &amp; Smoke Test-per C.S.A. C22.2 No. 0.3-92 Appendix B<sup>c</sup></p> |

a. Applies to cables shipped after April 1, 2009.

b. Cables will be marked with FT4 or CMG rating, but they all actually meet the more stringent FT4 rating.

c. Cables will be marked with FT6 or CMR rating, but they all actually meet the more stringent FT6 rating.

# Product Specifications

---

## International Approvals

The Tricon controller has been certified as complying with multiple internationally recognized standards by the following internationally recognized certification agencies, these certifications have qualified the Tricon for use around the world in safety critical applications. Test reports from the various certification agencies are available upon request.

**TÜV Rheinland** — TÜV has certified that the Tricon v9 and v10 controllers are in full compliance with the internationally recognized standards listed below, and thus are qualified for use in the following applications and jurisdictions.

- Emergency safety shut-down or other critical control applications requiring SIL 1-3 certification per the functional safety requirements of IEC 61508 9 (only Tricon v9.6 or later systems)
- Emergency safety shut-down or other critical control applications requiring AK 1-AK6 certification per the functional safety requirements of DIN V 19250 and DIN V VDE 0801 (only Tricon v9.x systems)
- Fire and gas detection applications requiring certification per the requirements of EN 54
- Fire and gas detection applications requiring certification per the requirements of NFPA 72 (only Tricon v9.6 or later systems)
- Burner management applications requiring certification per the requirements of DIN VDE 0116
- Burner management applications requiring certification per the requirements of NFPA 8501 or NFPA 8502 (only Tricon v9.6 or later systems)
- All applications in the European Union or other jurisdictions requiring compliance with the EMC Directive No. 89/336/EEC and Low Voltage Equipment Directive No. 72/23/EEC
- All applications in the European Union or other jurisdictions requiring compliance with the ATEX Directive No. 94/9/EC for Zone 2, Group IIB hazardous locations
- Environmental, health, and safety applications in semiconductor manufacturing facilities per the requirements of SEMI S2

For hazardous location applications, see the *Planning and Installation Guide for Tricon v9-v10 Systems* for application-specific installation instructions.

**Canadian Standards Association (CSA)** — CSA has certified that the Tricon v10 controller is in full compliance with the internationally recognized electrical safety standards and is qualified for general use in North American and other jurisdictions requiring compliance with these standards.

**Factory Mutual Research (FM)** — Factory Mutual has certified that the Tricon v10 controller is in full compliance with the internationally recognized standards and is qualified for use in Class I, Division 2 Temperature T4, Groups A, B, C, and D hazardous indoor (or outdoor in a NEMA 4 cabinet) locations. For hazardous location applications, see the *Planning and Installation Guide for Tricon v9-v10 Systems* for application-specific installation instructions.

**Bureau Veritas (BV)** — BV has certified specific Tricon products as being in full compliance with the internationally recognized standard and qualified for use in marine environments. For more information, see “Tricon Equipment Certified for Use in Marine Environments” on page 21. Also, for application-specific installation instructions, see the *Planning and Installation Guide for Tricon v9-v10 Systems*.

**European Union CE Mark** — Based upon the independent TÜV evaluation and test results, Triconex has certified the Tricon controller is suitable to use in the European Union and all other jurisdictions requiring compliance with the European Union EMC Directive No. 89/336/EEC and Low Voltage Equipment Directive No. 72/23/EEC, see Certificate of Compliance for details. For hazardous location applications, see the *Planning and Installation Guide for Tricon v9-v10 Systems* for application-specific installation instructions.

**U.S. Nuclear Regulatory Commission (NRC)** — The NRC has certified that the Tricon controller is suitable for use in nuclear 1E applications within the limitations and guidelines referenced in the NRC Safety Evaluation Report (SER) ML013470433, *Review of Triconex Corporation Topical Reports 7286-545, “Qualification Summary Report” and 7286-546, “Amendment 1 To Qualification Summary Report,” Revision 1*. This report is available from the NRC via the Agency Document Access and Management System (ADAMS) website. This qualification was based upon EPRI TR-107330, *Generic Requirements Specification for Qualifying a Commercially Available PLC for Safety-Related Applications in Nuclear Power Plants*. For details on models and revisions qualified for 1E applications, please contact Invensys Nuclear by calling toll-free 866-703-6300, toll 949-885-0885, or visit the Invensys Nuclear website at <http://www.invensysnuclear.com>.

### Chassis Options

A Tricon system is made up of one or more chassis assemblies which contain I/O and communication modules. The first chassis of a system is called the Main Chassis (Model 8110). To enlarge a system, Expansion Chassis (Model 8111 or 8121) and/or RXM Chassis (Model 8112) can be added. (See “System Configuration” on page 11 for details.)

### I/O Expansion Bus

Each chassis has six RS-485 I/O expansion bus ports at the top left corner of the backplane. There are two sets of ports for channels A, B, and C, providing for two triplicated serial communications paths between chassis. One set of cables is required for each Expansion Chassis and for the RXM Chassis which houses the primary RXM Module set. The standard length of a cable set (Model 9000) is 6 feet—longer cables are available if needed.

The triplicated I/O bus transfers data between the I/O modules and the Main Processors at 375 kilobits per second. The communication bus runs between the Main Processors and the communication modules at 2 megabits per second.

### Mechanical Specifications

These specifications apply to Main, Expansion, and RXM Chassis; Power Supply Modules; and other modules where indicated.

|                            |   |
|----------------------------|---|
| Overall Dimensions         | 19 in wide by 22.75 in high by 17.75 in deep<br>(48.3 cm by 57.8 cm by 45.1 cm) |
| Chassis Fabrication        | Black zinc-plated and welded cold-rolled steel                                  |
| Approximate Weights        |   |
| Main or Expansion Chassis  | 54.0 lbs. (24.5 kg.)  |
| Power Module               | 7.2 lbs. (3.3 kg.)  |
| Main Processor             | 4.7 lbs. (2.1 kg.)  |
| I/O Module                 | 4.7 to 6.0 lbs. (2.1 kg. to 2.7 kg.)  |
| HART Interface Module      | 4.8 lbs. (2.2 kg.)  |
| Communication Module       | 5.0 lbs. (2.3 kg.)  |
| 16-point Termination Panel | .09 lbs. (.04 kg.)  |
| 32-point Termination Panel | 2.1 lbs. (.95 kg.)  |

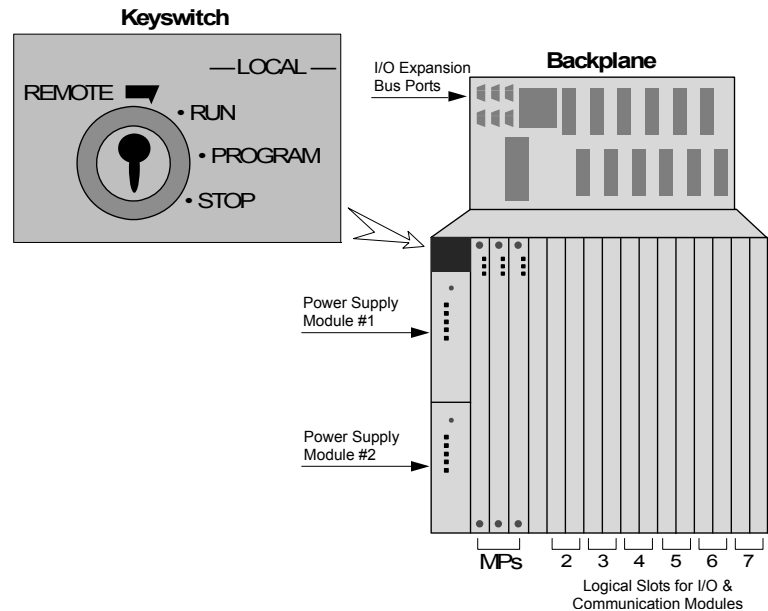

### Keyswitch for System Control

The Main Chassis has a four-position keyswitch which controls all the chassis in the system. The keyswitch setting is readable by Tricon controllers, TriStation 1131 software, and the control programs. Switch settings are:

**RUN**—Normal operation with read-only capability. The Main Processors execute the previously-loaded control

program. Attempts to modify program variables by a TriStation 1131 application, Modbus masters, or external hosts are rejected. However, a control program may call gated access functions to enable external host writes during a designated window of time.

**PROGRAM**—For program loading and checkout. Allows control of the Tricon system from the TriStation 1131 platform, including Download All and Download Changes. Also allows writes to program variables by external hosts.

**STOP**—Stops reading inputs, forces non-retentive digital and analog outputs to 0, and halts the control program. (Retentive outputs retain the value they had before the keyswitch was turned to Stop.) The Stop setting can be used for installation and service of process-related equipment, *but is not required for service of the Tricon controller.*

**REMOTE**—Allows writes to program variables by TriStation 1131 application and external hosts. (Download All and Download Changes by the TriStation 1131 software are not allowed.) Modification of program logic is not allowed.

# Product Specifications

## Chassis and Mounting Specifications

The Tricon system can be rack-mounted or panel-mounted in an industry-standard NEMA enclosure as described on the next page. Cabinets can optionally be equipped with base and casters. Multiple cabinets can be bolted together on the sides, but sufficient clearance must be allowed to fully open their front and rear doors.

## Slot Covers

All unused slots in a chassis should be filled with Blank I/O Slot Panels (Model 8105) to maintain proper air flow.

## Heat Management

When mounting Tricon chassis into vented or non-vented enclosures, the

integration engineer must make provisions for sufficient heat management.

You can manage the temperature of the enclosure by using either convection cooling or fans.

All enclosure installations must meet these two requirements:

- The temperature rise through each chassis must not exceed 27° F (15° C), as measured at the screened area at the top of the chassis at all points.
- The inlet temperature into the screened area at the bottom of each chassis must not exceed 140° F (60° C) at all points.

For temperatures above 86° F, Invensys recommends installing baffles (Triconex part number 2000361-001), as shown on page 25. For higher temperatures, other heat management components should be implemented:

- Louvers and pagoda top
- Lower-density filters
- Redundant fans (running all the time)
- Failure detection circuitry

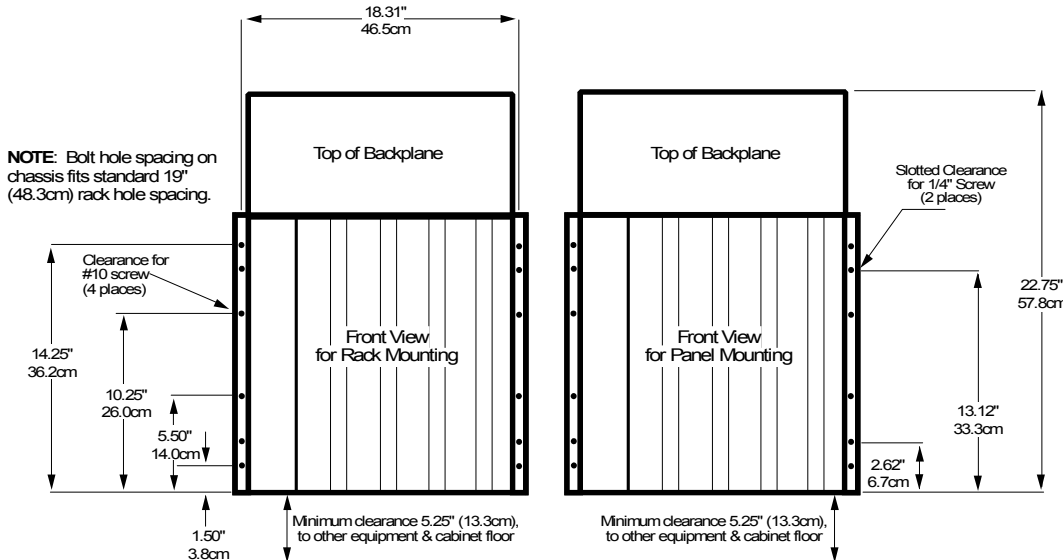
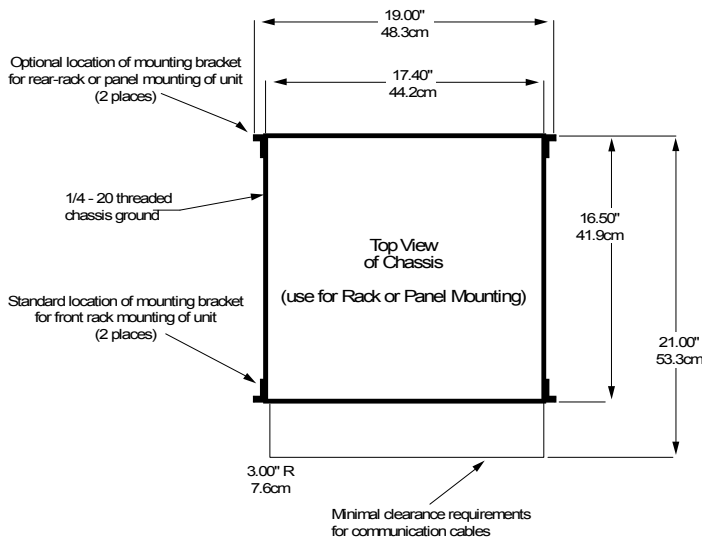

Dimensions and Clearances for Rack and Panel Mounting

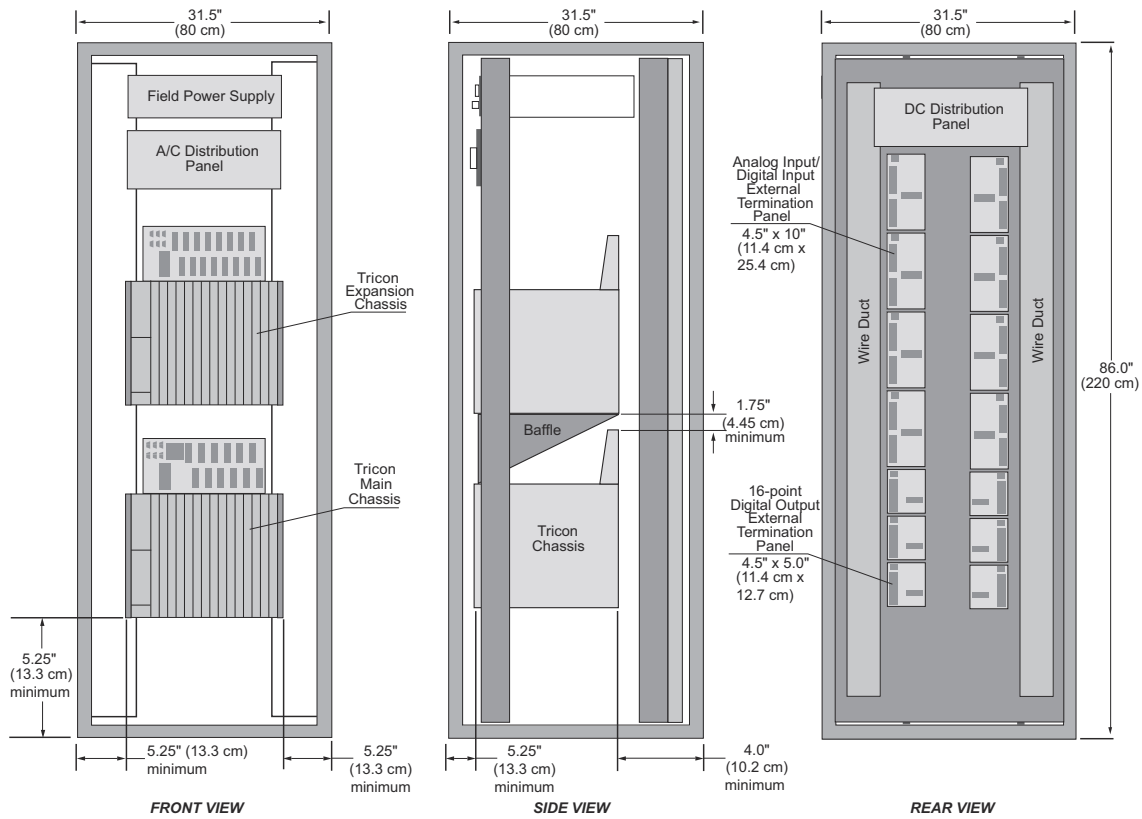

**Typical Dimensions and Clearances for Chassis Installation with External Terminations**

**NOTE**

*This drawing shows a typical set-up for external termination panels—other set-ups are possible. Please contact the Invensys Global Customer Support (GCS) center for details.*

**Clearances**

Invensys recommends that you leave a minimum of 5.25 inches (13.3 centimeters) of space between the enclosure panels and the bottom screen, sides, and front of each chassis, and a minimum of 5.25 inches (13.3 centimeters) of space between the top screen of each chassis and any obstructions to airflow.

**Mounting Tricon Chassis in Enclosures**

Invensys will mount Tricon chassis in any of the industry-standard enclosures listed below. (Please contact Invensys regarding other enclosures, available for additional engineering and documentation charges.) See page 14 for a photograph of Tricon chassis and terminations mounted in a sample enclosure.

**Enclosures Typically Supported by Invensys\***

| Type           | Width                | Depth                | Height                 |
|----------------|----------------------|----------------------|------------------------|
| Rittal NEMA 12 | 31.5 inches (800 mm) | 31.5 inches (800 mm) | 86.0 inches (2,200 mm) |
|                | 31.5 inches (800 mm) | 31.5 inches (800 mm) | 78.0 inches (2,000 mm) |
| MarkHon NEMA 1 | 31.5 inches (800 mm) | 31.5 inches (800 mm) | 85.0 inches (2,160 mm) |

\* Other sizes are available. Please contact Invensys for more information.

# Product Specifications

## Power Modules

Each Tricon chassis is equipped with two Power Modules—either one is fully capable of running the Tricon controller at full load and rated temperature. Each Power Module can be replaced online. The Power Modules, located on the left side of the chassis, convert line power to DC power appropriate for all Tricon modules. Terminal strips for system grounding, incoming power and hard-wired alarms are located on the lower left corner of the backplane. Incoming power should be rated for a minimum of 240 watts per power supply.

The Power Module alarm contacts are actuated when:

- A module is missing from the system
- The hardware configuration conflicts with the control program’s logical configuration
- A module fails
- A Main Processor detects a system fault
- Primary power to a Power Module fails
- A Power Module has a “Low Battery” or “Over Temperature” warning

**WARNING:** Do not use the Model 8312 Power Module in Tricon systems that are located in hazardous locations and must meet ATEX requirements. If you have 230 V line voltage and your system must meet ATEX requirements,

use the Model 8311 24 VDC Power Module along with the ATEX-certified 24 VDC power supply from Phoenix Contact (part number: QUINT-PS-100-240AC/24DC/10/EX).

**Front Panel of Power Module:**  
(located on lower left side of chassis)

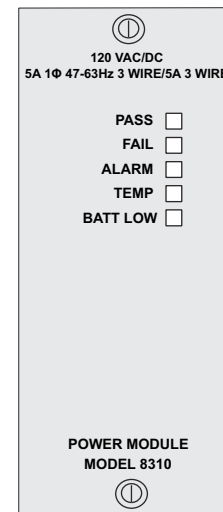

## Power Module Specifications

|                      |  |
|----------------------|--|
| Isolation            | >1,000 VAC or 1,500 VDC, Input to Output   |
| Input Terminations   | Protected by safety cover<br>Accepts three 12-gauge wires (3.310mm <sup>2</sup> ): neutral, hot, and protective earth (chassis ground)                           |
| Over-Temp. Sensor    | Temperature warning monitor—trips when internal temp. is greater than 181° F (83° C); this typically occurs at ambient temperature 140° F (60° C) or higher      |
| Alarm Contacts       | Normally open, normally closed and common<br>Each contact supports 120 VAC @ 1 amp<br>Accepts 12-gauge (3.310mm <sup>2</sup> ) wire<br>Protected by safety cover |
| Input Power Required | 240 watts minimum per Power Module   |
| Output Power         | 175 watts at 140° F (60° C)  |
| Output Voltage       | 6.5 VDC, ±1% under all operating conditions  |
| Output Current       | 27 amps maximum at 140° F (60° C) ambient  |

**Terminal Strip for Power Module:**  
(located on backplane above the Power Module)

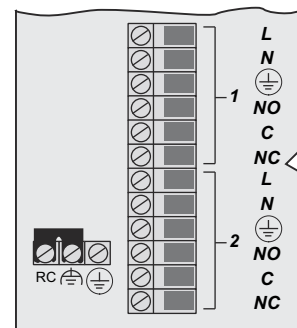

| Power Module Model                    | 8310                              | 8311                              | 8312                              |
|---------------------------------------|-----------------------------------|-----------------------------------|-----------------------------------|
| Chassis Type                          | Main/Expansion/RXM                | Main/Expansion/RXM                | Main/Expansion/RXM                |
| Nominal Voltage                       | 120 VAC/VDC                       | 24 VDC                            | 230 VAC                           |
| Input VAC @ 47-63 Hz                  | 85–140                            | n/a                               | 185–285                           |
| Input VDC                             | 95–180                            | 20.4–28.8                         | n/a                               |
| Fuse Rating and Type                  | 5 amps, time-delay                | 15 amps, time-delay               | 2.5 amps, time-delay              |
| Output Hold Time (nominal to 0 volts) | 20 ms minimum                     | 2.8 ms minimum                    | 20 ms minimum                     |
| Diagnostic Indicators                 | PASS, FAULT, ALARM, TEMP, BAT LOW | PASS, FAULT, ALARM, TEMP, BAT LOW | PASS, FAULT, ALARM, TEMP, BAT LOW |

### Main Processor Modules

Model 3008 Main Processors (MP) are available for Tricon v9.6 and later systems. For detailed specifications, see the *Planning and Installation Guide for Tricon Systems*.

Three MPs must be installed in the Main Chassis of every Tricon system. Each MP independently communicates with its I/O subsystem and executes the user-written control program.

### Sequence of Events (SOE) and Time Synchronization

During each scan, the MPs inspect designated discrete variables for state changes known as *events*. When an event occurs, the MPs save the current variable state and time stamp in the buffer of an SOE block.

If multiple Tricon systems are connected by means of NCMs, the time synchronization capability ensures a consistent time base for effective SOE time-stamping. See page 78 for more information.

### Diagnostics

Extensive diagnostics validate the health of each MP, I/O module and communication channel. Transient faults are recorded and masked by the hardware majority-voting circuit. Persistent faults are diagnosed and the errant module is hot-replaced.

MP diagnostics perform these tasks:

- Verify fixed-program memory and static RAM

- Test all basic processor and floating-point instructions and operating modes
- Validate user memory by means of the TriBus hardware-voting circuitry
- Verify the shared memory interface with each I/O communication processor and channel
- Verify handshake and interrupt signals between the CPU, each I/O communication processor and channel
- Check each I/O communication processor and channel microprocessor, ROM, shared memory access and loopback of RS-485 transceivers
- Verify the TriClock and TriBus interfaces

### Physical Description of Model 3008 Main Processors

| Feature                                  | Description  |
|--|--|
| Microprocessor                           | Motorola MPC860, 32 bit, 50 MHz  |
| Memory                                   | <ul style="list-style-type: none"> <li>• 16 MB DRAM (non-battery backed-up)</li> <li>• 32 KB SRAM, battery backed-up</li> <li>• 6 MB Flash PROM</li> </ul> |
| Tribus Communication Rate                | <ul style="list-style-type: none"> <li>• 25 megabits per second</li> <li>• 32-bit CRC protected</li> <li>• 32-bit DMA, fully isolated</li> </ul>           |
| I/O Bus and Communication Bus Processors | <ul style="list-style-type: none"> <li>• Motorola MPC860</li> <li>• 32 bit</li> <li>• 50 MHz</li> </ul>  |

### Indicators on Main Processors

|        |  |
|--------|--|
| PASS   | Module has passed self-diagnostic tests              |
| FAULT  | Module has a fault and should be replaced            |
| ACTIVE | Module is executing the user-written control program |
| MAINT1 | Maintenance indicator 1                              |
| MAINT2 | Maintenance indicator 2                              |
| COM TX | Transmitting data across COMM bus                    |
| COM RX | Receiving data from COMM bus                         |
| I/O TX | Transmitting data across I/O bus                     |
| I/O RX | Receiving data from I/O bus                          |

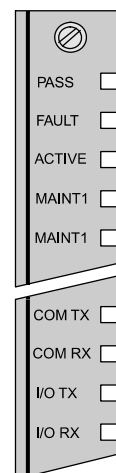

### Tricon Communication Module

The Tricon Communication Module (TCM), which is compatible with only Tricon v10.0 and later systems, allows the Tricon controller to communicate with the TriStation 1131 software, other Tricon, Trident™, or Tri-GP controllers, Modbus master and slave devices, and external hosts over Ethernet networks.

Each TCM contains four serial ports, two network ports, and one debug port (for Invensys use).

Each serial port is uniquely addressed and can be configured as a Modbus master or slave. Serial Port #1 supports either the Modbus or the Trimble GPS interface. Serial Port #4 supports either the Modbus or the TriStation interface. Each TCM supports an aggregate data rate of 460.8 kilobits per second, for all four serial ports.

Any standard Modbus device can communicate with the Tricon controller through the TCM, provided that aliases are assigned to the Tricon variables.

# Product Specifications

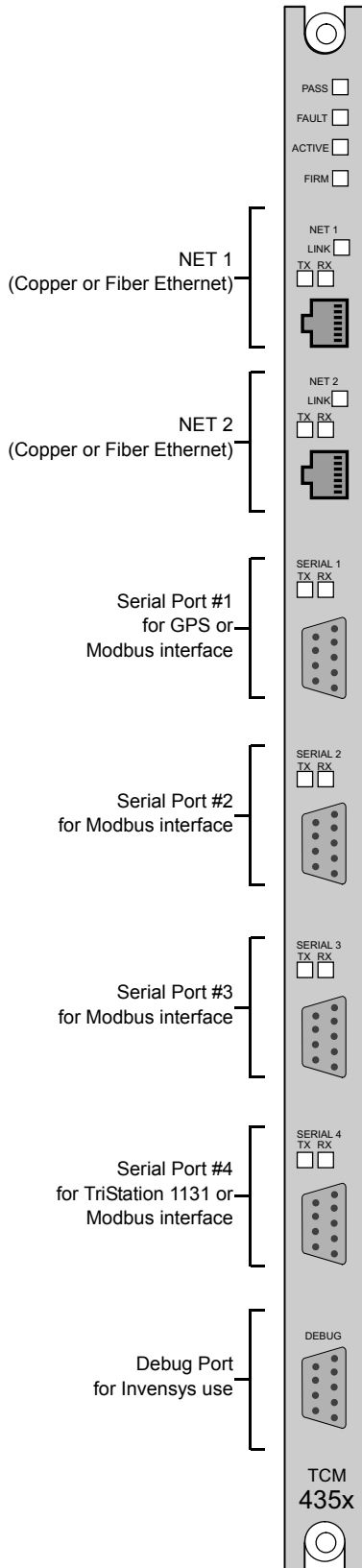

Alias numbers must also be used when host computers access the Tricon controller through other communication modules. See “Communication Capabilities” on page 67 for more information.

TCM Models 4353 and 4354 have an embedded OPC server on NET 2, which allows up to 10 OPC clients to subscribe to data collected by the OPC Server. The embedded OPC Server supports the Data Access 2.05 standard and the Alarms and Events 1.10 standard.

Each TCM contains two network ports—NET 1 and NET 2. Models 4351A, 4351B, and 4353 have two copper Ethernet (802.3) ports and Models 4352A, 4352B, and 4354 have two fiber-optic Ethernet ports.

On TCM Models 4351A, 4351B, 4352A, and 4352B, NET 1 and NET 2 support the TCP/IP, Modbus TCP/IP Slave/Master, TSAA, TriStation, SNTP, and Jet Direct (for network printing) protocols. NET 1 also

supports the Peer-to-Peer (UDP/IP) and Peer-to-Peer Time Synchronization protocols.

On TCM Models 4353 and 4354, NET 2 supports only the embedded OPC server, TriStation, and SNTP protocols, while NET 1 supports all of the listed protocols except the embedded OPC server.

A single Tricon system supports a maximum of four TCMs, which must reside in two logical slots. Different TCM Models cannot be mixed in one logical slot. Each Tricon system supports a total of 32 Modbus masters or slaves—this total includes network and serial ports. The hot-spare feature is not available for the TCM, though you *can* replace a faulty TCM while the controller is online.

## TCM Specifications

| Model Number               | 4351A, 4351B, 4352A, 4352B, 4353, 4354   |  |
|----------------------------|--|--|
| Serial ports               | 4, RS-232/RS-485 ports, DB-9 connectors  |  |
| Network ports              | 2, 10/100BaseT Ethernet ports, RJ-45 connectors (Models 4351A, 4351B, 4353)<br>2, fiber-optic mode Ethernet ports, MT-RJ connectors with 62.5/125 um fiber cables (Models 4352A, 4352B, 4354)                                  |  |
| Port isolation             | 500 VDC  |  |
| Protocols                  | TriStation, Modbus, TCP/IP, ICMP, SNTP, TSAA (with support for IP Multicast), Trimble GPS, Embedded OPC Server (Models 4353 and 4354), Peer-to-Peer (UDP/IP), Peer-to-Peer Time Synchronization, Jet Direct (network printing) |  |
| Modbus functions supported | 01 — Read Coil Status<br>02 — Read Input Status<br>03 — Read Holding Registers<br>04 — Read Input Registers<br>05 — Modify Coil Status   | 06 — Modify Register Content<br>07 — Read Exception Status<br>08 — Loopback Diagnostic Test<br>15 — Force Multiple Coils<br>16 — Preset Multiple Registers |
| Communication speed        | Copper Ethernet ports: 10/100 Mbps (Model 4353 supports only 100 Mbps)<br>Fiber Ethernet ports: 100 Mbps<br>Serial ports: up to 115.2 Kbps per port  |  |
| Status Indicators          | PASS, FAULT, ACTIVE, FIRM<br>LINK— 1 per network port, TX (Transmit) — 1 per port, RX (Receive) — 1 per port   |  |

### Enhanced Intelligent Communication Module

The Model 4119A Enhanced Intelligent Communication Module (EICM) allows the Tricon controller to communicate with Modbus masters and slaves, the TriStation 1131 software, and printers.

For Modbus connections, the EICM user can select the RS-232 point-to-point interface for one master and one slave, or the RS-485 interface for one master and up to 32 slaves. The RS-485 network trunk can be one or two twisted-pair wires up to a maximum of 4,000 feet (1,200 meters).

Each EICM contains four serial ports and one parallel port which can operate concurrently. Each serial port can be configured as a Modbus master with up to seven Modbus masters per Tricon chassis. A single Tricon system supports a maximum of two EICMs, which must reside in one logical slot. (The hot-spare feature is not available for the EICM, though you can replace a faulty EICM while the controller is online.) Each serial port is uniquely addressed and supports either the

Modbus or TriStation interface. Modbus communication can be performed in either RTU or ASCII mode. The parallel port provides a Centronics interface to a printer.

Each EICM supports an aggregate data rate of 57.6 kilobits per second (for all four serial ports).

Programs for the Tricon controller use variable names as identifiers but Modbus devices use numeric addresses called *aliases*. Therefore an alias must be assigned to each Tricon variable name that will be read by or written to a Modbus device. An alias is a five-digit number which represents the Modbus message type and the address of the variable in the Tricon controller. An alias number is assigned in the TriStation 1131 software.

Any standard Modbus device can communicate with the Tricon controller through the EICM, provided that aliases are assigned to the Tricon variables. Alias numbers must also be used when host computers access the Tricon controller through other communication modules, such as the NCM. See “Communication Capabilities” on page 67 for more information.

### EICM Specifications

| Model Number               | 4119A, Isolated  |
|----------------------------|--|
| Serial ports               | 4 ports RS-232, RS-422 or RS-485   |
| Parallel ports             | 1, Centronics, isolated  |
| Port isolation             | 500 VDC  |
| Protocol                   | TriStation, Modbus   |
| Modbus functions supported | 01 — Read Coil Status<br>02 — Read Input Status<br>03 — Read Holding Registers<br>04 — Read Input Registers<br>05 — Modify Coil Status<br>06 — Modify Register Content<br>07 — Read Exception Status<br>08 — Loopback Diagnostic Test<br>15 — Force Multiple Coils<br>16 — Preset Multiple Registers |
| Communication speed        | 1200, 2400, 9600, or 19,200 Baud   |
| Diagnostic Indicators      | Pass, FaULT, Active<br>TX (Transmit) — 1 per port<br>RX (Receive) — 1 per port   |

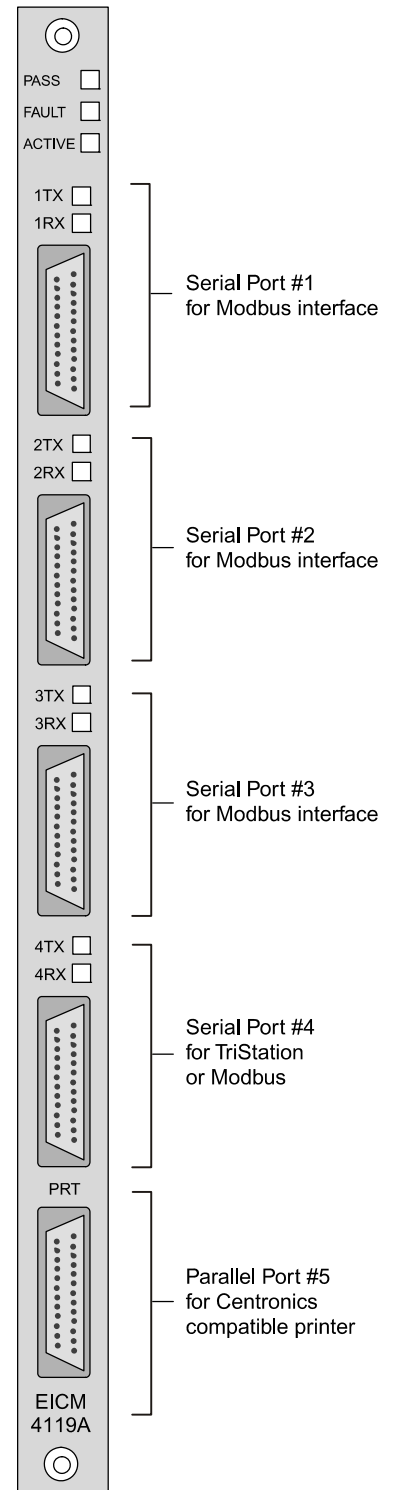

# Product Specifications

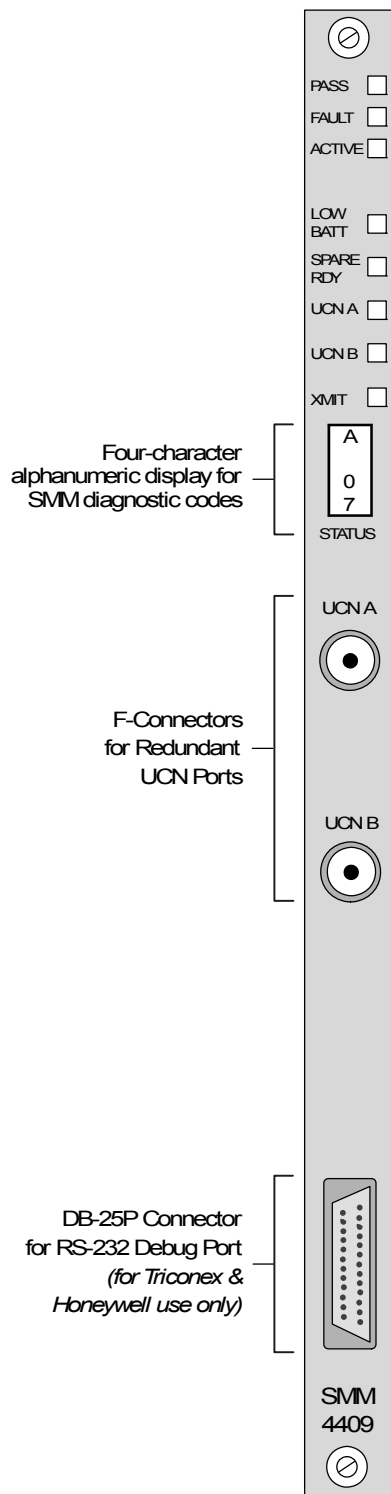

## Safety Manager Module

The Model 4409 Safety Manager Module (SMM) acts as an interface between a Tricon controller and a Honeywell Universal Control Network (UCN), one of three principal networks of the TDC-3000 Distributed Control System. Appearing to the Honeywell system as a safety node on the UCN, the SMM communicates process information at full network data rates for use anywhere on the TDC-3000. The SMM transmits Tricon aliased data (including system variables) and diagnostic information to operator workstations in display formats that are familiar to Honeywell operators.

The SMM makes the following functions available to the TDC-3000:

- Handles critical I/O points and passes results to the DCS
- Processes Tricon controller alarms and propagates them to user-defined DCS destinations (consoles, printers, etc.)
- Reads/writes aliased data to satisfy DCS requests

- Reads Tricon controller diagnostics for display by the DCS
- Write protection to lock out changes to the Tricon controller from all TDC-3000 sources
- *Time synchronization* from the DCS master clock
- *Peer-to-Peer communication* for plants with many Tricon controllers, each containing an SMM—the DCS can use shared data to alert downstream Tricon controllers of significant process changes
- *Sequence of Events*—transmits Tricon controller event data to Universal Stations for display or History Modules for recording, to help determine the cause of plant trips and increase process up-time
- Hot-spare capability for uninterrupted communication with Honeywell networks

## SMM Specifications

|                     |  |
|---------------------|--|
| <b>Model Number</b> | <b>4409</b>  |
| UCN ports           | 2 isolated (AC coupled)  |
| UCN data rate       | 5 MBytes per second  |
| Status indicators   | PASS (Module Status)<br>FAULT (Module Status)<br>ACTIVE (Module Status)<br>LOW BATT (Low Battery)<br>SPARE RDY (Hot Spare Ready)<br>UCN A (UCN Port A Active)<br>UCN B (UCN Port B Active)<br>XMIT (SMM Transmitting)<br>STATUS (Module Node and Diagnostic Info.) |
| Power Module load   | < 20 watts   |
| Isolation           | 500 VDC  |

## Network Communication Module

With a Model 4329 Network Communication Module (NCM) installed, the Tricon controller can communicate with other Tricon controllers and with external hosts over Ethernet (802.3) networks. The NCM supports a number of Triconex proprietary protocols and applications as well as user-written applications, including those that use the TSAA protocol.

The NCMG module has the same functionality as the NCM, as well as the ability to synchronize time based on a GPS system. For more information, see the *Communication Guide for Tricon Systems*.

The NCM provides two BNC connectors as ports: NET 1 supports Peer-to-Peer and Time Synchronization protocols for safety networks comprised of Tricon controllers only. NET 2 supports open networking to external systems using Triconex applications such as the TriStation 1131

software, SOE, OPC Server, and DDE Server or user-written applications. See “Communication Capabilities” on page 67 for more information about Triconex protocols and applications.

Two NCMs can reside in one logical slot of the Tricon chassis, but they function independently, not as hot-spare modules. External hosts can read or write data only to Tricon variables to which Alias numbers have been assigned. (See “Enhanced Intelligent Communication Module” on page 35 for more information about Aliases.)

The NCM is compatible with Ethernet (IEEE 802.3 electrical interface) and operates at 10 megabits per second. The NCM connects with external host computers by means of coaxial cable (RG58) at typical distances up to 607 feet (185 meters). Distances up to 2.5 miles (4,000 meters) are possible using repeaters and standard (thick-net or fiber-optic) cabling.

The Main Processors typically refresh data on the NCM once per scan.

## NCM Specifications

|                            |   |
|----------------------------|---|
| <b>Model Number</b>        | <b>4329, 4329G</b>  |
| Ethernet (802.3) ports     | 2, BNC connectors, RG58 50-ohm thin cable   |
| External Transceiver Ports | 2, 15-pin D-connectors  |
| Serial port                | 1, RS-232 compatible  |
| Port Isolation             | 500 VDC   |
| Protocol                   | TSAA<br>(TCP(UDP)/IP/802.3)   |
| Functions supported        | TRICON_DATA (Frame Type 1)<br>TRICON_DATA_REQ (Frame Type 2)<br>WRITE_TRICON_DATA (Frame Type 3)<br>WRITE_TRICON_DATA_RSP (Frame Type 4)<br>READ_TRICON_CLOCK (Frame Type 5)<br>READ_TRICON_CLOCK_RSP (Frame Type 6)<br>SET_TRICON_CLOCK (Frame Type 7)<br>SET_TRICON_CLOCK_RSP (Frame Type 8)<br>READ_TRICON_DATA (Frame Type 11)<br>READ_TRICON_RSP (Frame Type 12) |
| Communication speed        | 10 megabits per second (for Ethernet ports)   |
| Status indicators          | PASS, FAULT, ACTIVE<br>TX (Transmit) — 1 per port<br>RX (Receive) — 1 per port  |

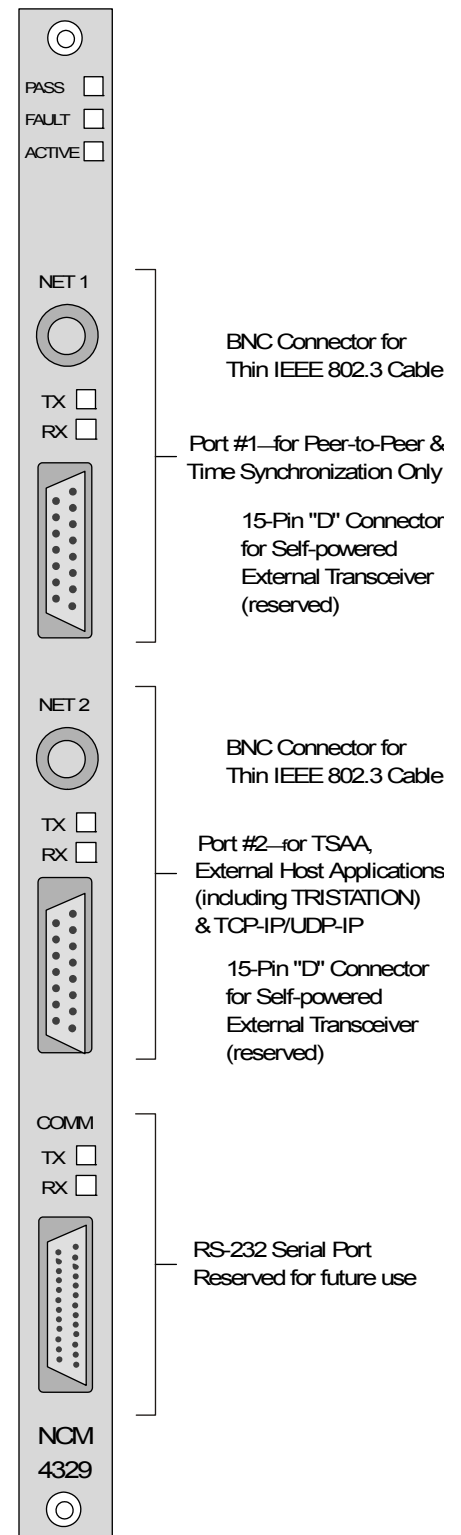

# Product Specifications

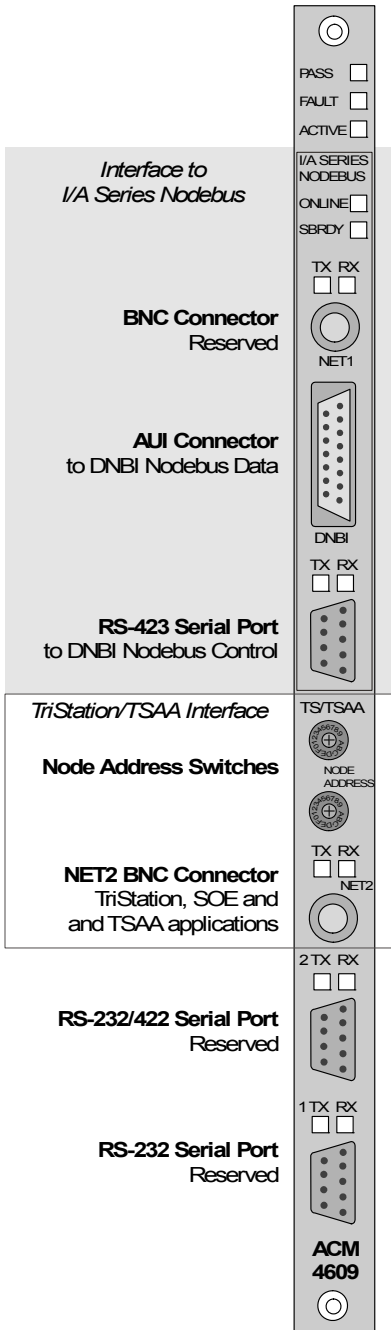

## Advanced Communication Module (ACM)

The Model 4609 Advanced Communication Module (ACM) acts as an interface between a Tricon controller and a Foxboro Intelligent Automation (I/A) Series system, appearing to the Foxboro system as a safety node on the I/A Series Nodebus. The ACM communicates process information at full network data rates for use anywhere on the I/A Series system, transmitting all Tricon aliased data (including system variables and system aliases) and diagnostic information to operator workstations in display formats that are familiar to Foxboro operators. The ACM makes the following functions available to the I/A Series:

- Handles critical I/O points and passes results to the I/A Series using the Object Management Database (OMDB)
- Processes Tricon controller alarms and propagates them to user-defined I/A Series destinations (consoles, printers, and so on)

- Propagates Tricon controller alarms as I/A Series system messages
- Reads/writes aliased data to satisfy I/A Series requests
- Time synchronization from the I/A Series environment
- Reads Tricon controller diagnostics for display by the I/A Series workstation
- Write protection to lock out changes to the Tricon controller from all I/A Series sources
- Hot-spare capability for uninterrupted communication with the I/A Series Nodebus

The ACM also supports the following Triconex protocols and applications on external host PCs connected to a separate BNC port (labeled NET 2):

- TriStation protocol for the TriStation 1131 software
- TSAA protocol for Triconex applications
- TSAA/TCP (UDP/IP) for user-written applications on external hosts

## ACM Specifications

| Model Number                | 4609   |
|-----------------------------|--|
| <b>Nodebus Ports</b>        |  |
| BNC connector               | 1 for RG58 50-ohm thin cable (reserved)                        |
| 15-pin D connector          | 1 for AUI cable to DNBI  |
| 9-pin RS-423 connector      | 1 for Control Bus to DNBI                                      |
| NET 2 port <sup>a</sup>     | 1 BNC connector for RG58 50-ohm Thin cable to Ethernet network |
| 9-pin serial ports          | RS-232/RS-485 protocol (reserved)                              |
| Port isolation              | 500 VDC (Ethernet and RS-232 ports)                            |
| <b>Communication speeds</b> |  |
| BNC and 15-pin D connectors | 10 megabits per second   |
| 9-pin Nodebus connector     | 2400 baud  |
| <b>Status indicators</b>    |  |
| Module status               | PASS, FAULT, ACTIVE  |
| Nodebus/standby activity    | ONLINE and SBRDY   |
| Port activity               | TX and RX—1 each per port                                      |
| Power Module load           | 20 watts   |

a. The address for this port is set by the TS/TSAA Node Addresses switches.

### Hiway Interface Module

The Model 4509 Hiway Interface Module (HIM) acts as an interface between a Tricon controller and a Honeywell TDC-3000 control system by means of the Hiway Gateway and Local Control Network (LCN). The HIM can also interface with Honeywell's older TDC 2000 control system by means of the Data Hiway.

The HIM enables higher-order devices on the LCN or Data Hiway, such as computers and operator workstations,

to communicate with the Tricon controller.

The HIM allows redundant BNC connections directly to the Data Hiway and has the same functional capacity as four extended Data Hiway Port (DHP) addresses.

The HIM provides eight Hiway addresses, implements the same slot structure as the DHP, and typically refreshes all data in less than 0.5 seconds. The hot-spare capability allows online replacement of a faulty module.

### HIM Specifications

|                        |  |
|------------------------|--|
| <b>Model Number</b>    | <b>4509</b>  |
| Data Hiway channels    | 2 isolated (AC coupled)  |
| Poll response switches | 2 per channel  |
| Baud rate              | 250 kilobits per second  |
| Status indicators      | PASS (Module Status)<br>FAULT (Module Status)<br>ACTIVE (Module Status)<br>ON LN (HIM Online)<br>H I/F (Hiway Interface)<br>CAL UP (Call-up Received)<br>CH A (Channel A Active)<br>CH B (Channel B Active)<br>XMIT (HIM Transmitting)<br>STD BY IN (Standby Module Inserted)<br>STD BY READY (Standby Module Ready) |
| Power Module load      | < 10 watts   |
| Isolation              | 500 VDC  |

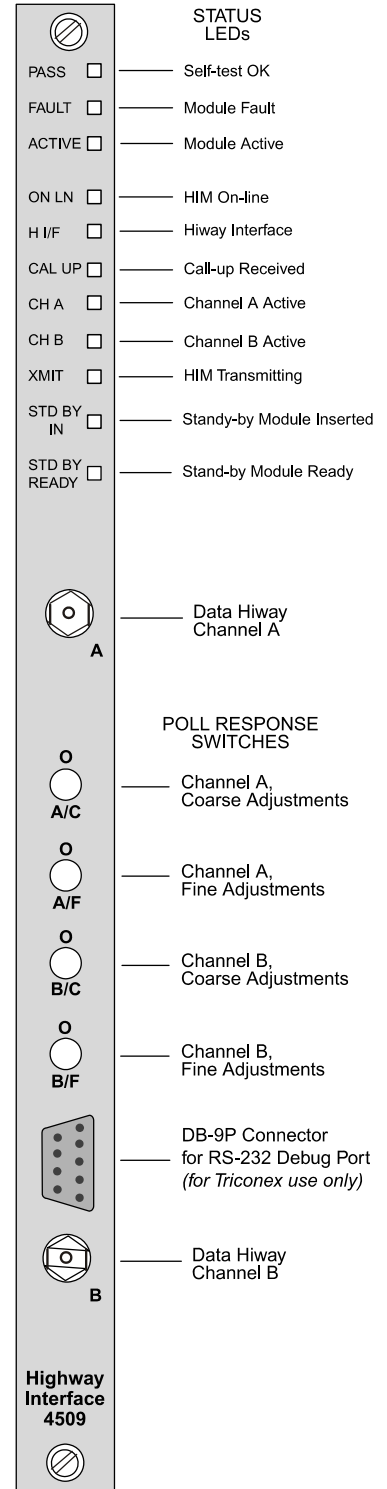

# Product Specifications

## Remote Extender Module (RXM)

RXMs and chassis allow I/O modules to be located several kilometers from the Main Chassis. RXM sets, consisting of three identical modules, serve as repeaters and extenders of the Tricon I/O bus and provide ground loop isolation. A primary RXM set supports three remote locations by connecting to three remote RXM sets housed in a remote chassis. See “System Configuration” on page 11 regarding configurations that use RXMs.

RXM sets are available for fiber-optic cables with a communication rate of 375 kilobits per second. These sets provide maximum immunity against electro-static and electro-magnetic interference, and support configurations with optical modems and fiber-optic point-to-point cabling. Remote sites can be located as far as 7.5 miles (12 kilometers) from the primary site.

The figure at right shows uni-directional cabling for three channels of a remote location. For each channel, one cable carries data transmitted from the primary RXM to the remote RXM, and the other cable carries data received by the primary RXM from the remote RXM. A pair of modules must be wired for each of the three channels, amounting to a total of six cables for each remote location.

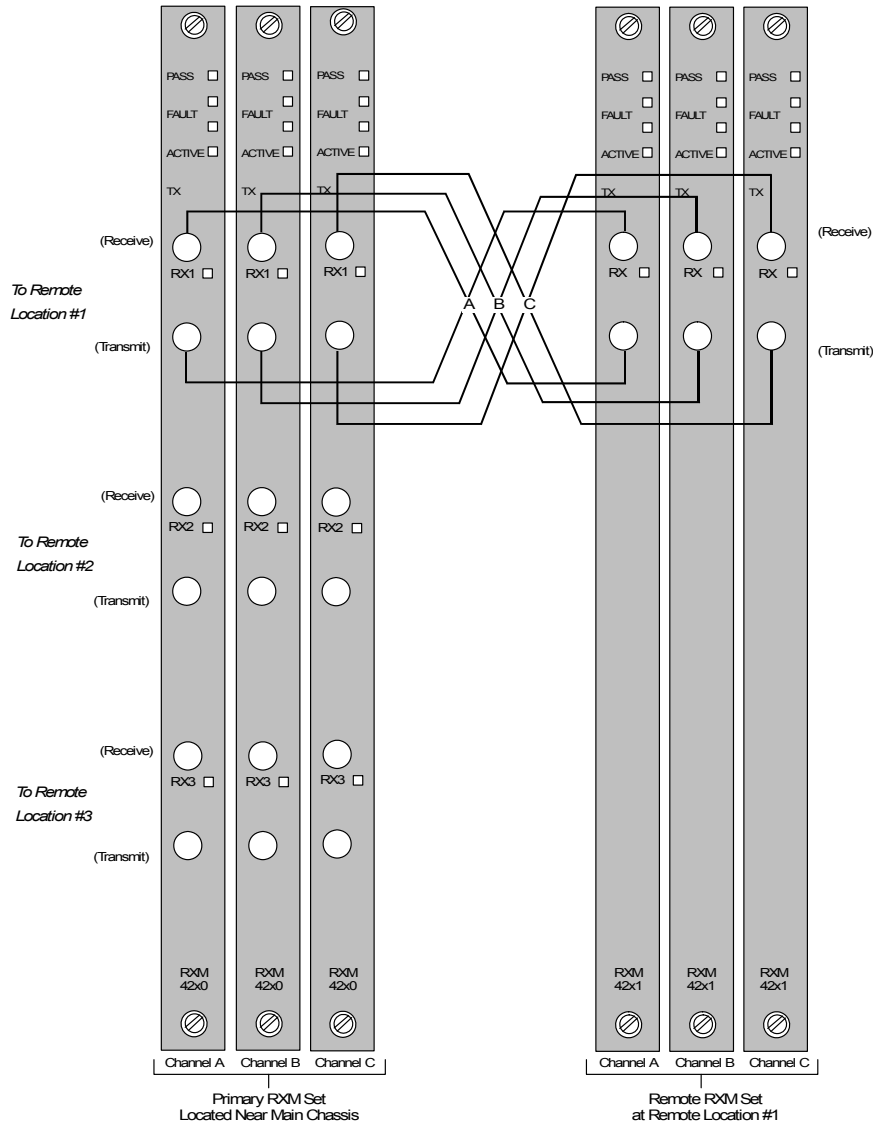

Sample Wiring for One Remote Location

**NOTE:** The selection and installation of fiber-optic cabling requires specialized knowledge, training and tools. Invensys recommends hiring a fiber-optic specialist to handle these tasks.

## RXM Specifications

| RXM Model              | 4200-3                                | 4201-3                                | 4210-3                                | 4211-3                                |
|------------------------|---------------------------------------|---------------------------------------|---------------------------------------|---------------------------------------|
| RXM Chassis Location   | Primary                               | Remote                                | Primary                               | Remote                                |
| Cable Type             | Multi-mode                            | Multi-mode                            | Single-mode                           | Single-mode                           |
| Cable Length Limit     | 1.2 miles (2 kilometers)              | 1.2 miles (2 kilometers)              | 7.5 miles (12 kilometers)             | 7.5 miles (12 kilometers)             |
| Connectors             | 6/remote site                         | 6                                     | 6/remote site                         | 6                                     |
| Remote Sites Supported | 3                                     | n/a                                   | 3                                     | n/a                                   |
| Modem Ports            | Fiber Optic with ST connectors        | Fiber Optic with ST connectors        | Fiber Optic with ST connectors        | Fiber Optic with ST connectors        |
| Diagnostic Indicators  | PASS, FAIL, ACTIVE, TX, RX1, RX2, RX3 | PASS, FAIL, ACTIVE, TX, RX1, RX2, RX3 | PASS, FAIL, ACTIVE, TX, RX1, RX2, RX3 | PASS, FAIL, ACTIVE, TX, RX1, RX2, RX3 |

## TMR Digital Input Modules

Each TMR Digital Input (DI) module has three isolated input channels which independently process all data input to the module. A microprocessor on each channel scans each input point, compiles data, and transmits it to the Main Processors upon demand. Then input data is voted at the Main Processors just prior to processing to ensure the highest integrity. All critical signal paths are 100 percent triplicated for guaranteed safety and maximum availability. Each channel conditions signals independently and provides optical isolation between the field and the Tricon controller.

All TMR Digital Input Modules sustain complete, ongoing diagnostics for each channel. Failure of any diagnostic on any channel activates the module Fault indicator, which in turn activates the chassis alarm signal. The module Fault indicator points to a channel fault, *not* a module failure. The module is guaranteed to operate properly in the presence of a single fault and may continue to operate properly with certain kinds of multiple faults.

Models 3502E, 3503E, and 3505E can self-test to detect stuck-On conditions where the circuitry cannot tell whether a point has gone to the Off state. Since most safety systems are set up with a

de-energize-to-trip capability, the ability to detect Off points is an important feature. To test for stuck-On inputs, a switch within the input circuitry is closed to allow a zero input (Off) to be read by the optical isolation circuitry. The last data reading is frozen in the I/O communication processor while the test is running.

All TMR Digital Input Modules support hot-spare capability, and require a separate external termination panel (ETP) with a cable interface to the Tricon controller backplane. Each module is mechanically keyed to prevent improper installation in a configured chassis.

## 32-Point Digital Input Module Specifications

| Model Number             | 3501E/3501T                      | 3502E                       | 3503E                       | 3505E                       |
|--------------------------|----------------------------------|-----------------------------|-----------------------------|-----------------------------|
| Type                     | TMR                              | TMR with Self-Test          | TMR with Self-Test          | TMR, Low Threshold          |
| Voltage                  | 115 VAC/VDC                      | 48 VAC/VDC                  | 24 VAC/VDC                  | 24 VDC                      |
| Points                   | 32, non-commoned, isolated       | 32, commoned in groups of 8 | 32, commoned in groups of 8 | 32, commoned in groups of 8 |
| AC Range/DC Range        | 90-155 VAC/VDC                   | 35-95 VAC/VDC               | 20-42.5 VAC/VDC             | 20-42.5 VDC                 |
| Frequency Range          | DC or 47-63 Hz                   | DC or 47-63 Hz              | DC or 47-63 Hz              | n/a                         |
| Maximum Voltage          | 155 VAC/VDC                      | 95 VAC/VDC                  | 42.5 VAC/VDC                | 42.5 VDC                    |
| Switching Level          |                                  |                             |                             |                             |
| Off to On <sup>a</sup>   | < 86 VAC/VDC                     | < 32 VAC/VDC                | < 18 VAC/VDC                | < 12 VDC                    |
| On to Off <sup>b</sup>   | > 28 VAC/VDC                     | > 11 VAC/VDC                | > 6 VAC/VDC                 | > 4 VDC                     |
| Nominal Turn-On          | 6-9 mA                           | 6-9 mA                      | 6-9 mA                      | 3 mA to 5 mA                |
| Typical Hysteresis       | 32 VAC/VDC                       | 7 VAC/VDC                   | 4 VAC/VDC                   | 2 VDC                       |
| Input Delay              |                                  |                             |                             |                             |
| OFF to ON/ON to OFF      | < 8 ms/< 15 ms                   | < 8 ms/< 15 ms              | < 8 ms/< 15 ms              | < 8 ms/< 15 ms              |
| Point Isolation          | 1,500 VDC/ 2500 VDC <sup>c</sup> | 1,500 VDC                   | 1,500 VDC                   | 1,500 VDC                   |
| Nominal Input Impedance  | > 8.5 K $\Omega$                 | > 2.9 K $\Omega$            | > 1.25 K $\Omega$           | > 1.25 K $\Omega$           |
| Nominal Field Power Load |                                  |                             |                             |                             |
| Per On point             | 1.5 watts                        | 1.0 watts                   | 0.5 watts                   | 0.5 watts                   |
| @ max. field voltage     | 2.9 watts                        | 3.2 watts                   | 1.5 watts                   | 1.5 watts                   |
| Diagnostic Indicators    |                                  |                             |                             |                             |
| Input Status             | 1 per point                      | 1 per point                 | 1 per point                 | 1 per point                 |
| Module Status            | PASS, FAULT, ACTIVE              | PASS, FAULT, ACTIVE         | PASS, FAULT, ACTIVE         | PASS, FAULT, ACTIVE         |
| Stuck Test               | n/a                              | On                          | On                          | On                          |
| Color Code               | Red                              | Dark Red                    | Dark Red                    | Dark Red                    |

a. Off to On transition is guaranteed at or above this level but it might occur at a lower voltage, depending on the module's hysteresis.

b. On to Off transition is guaranteed at or below this level but it might occur at a higher voltage, depending on the module's hysteresis.

c. For 3501T.

## Product Specifications

### 64-Point Digital Input Modules

Each 64-point Digital Input (DI) module has three isolated channels which independently process all data input to the module. A microprocessor on each channel scans each input point, compiles data and transmits it to the Main Processors on demand. Then input data is voted at the Main Processors just prior to processing to ensure the highest integrity.

All Digital Input Modules sustain complete, ongoing diagnostics for each channel. A failure on any channel activates the Fault indicator which in turn activates the chassis alarm. A TMR module is guaranteed to operate properly in the presence of a single fault and

may operate properly with certain kinds of multiple faults.

All Digital Input Modules support hot-spare modules and require a separate external termination panel (ETP) with a cable interface to the Tricon controller backplane. Each module is mechanically keyed to prevent improper installation in a chassis.

The Model 3504E High-Density Digital Input Module continuously verifies the ability of the Tricon controller to detect transitions to the opposite state. On this TMR module, all critical signal paths are 100 percent triplicated for guaranteed safety and maximum availability. Each channel conditions signals independently between the field and the Tricon controller.

The Model 3564 Single Digital Input Module is optimized for safety-critical applications where low cost is more important than maximum availability. On single modules, only those portions of the signal path which are required to ensure safe operation are triplicated. Special self-test circuitry detects all stuck-On and stuck-Off fault conditions in less than half a second. If a single module detects an input fault, it reports that point as Off, which may cause a glitch during switch-over to a hot-spare module.

### 64-Point Digital Input Module Specifications

| Model Number             | 3564                | 3504E                     |
|--------------------------|---------------------|---------------------------|
| Type                     | Single, DI          | TMR, DI                   |
| Voltage                  | 24 VDC              | 24 or 48 VDC <sup>a</sup> |
| Points                   | 64, commoned        | 64, commoned, DC coupled  |
| DC Range                 | 15-30 VDC           | 20-72 VDC                 |
| Maximum Voltage          | 36 VDC              | 72 VDC                    |
| Switching Level          |                     | <u>24 V</u> <u>48 V</u>   |
| OFF to ON <sup>b</sup>   | > 15 VDC            | >18 VDC    >32 VDC        |
| ON to OFF <sup>c</sup>   | < 6 VDC             | < 6 VDC    <11 VDC        |
| Nominal Turn-On          | 2-3 mA              | negligible                |
| Typical Hysteresis       | 4 VDC               | 4 VDC/7 VDC               |
| Input Delay              |                     |                           |
| Off to On/On to Off      | < 2 ms/< 2 ms       | < 10 ms/< 10 ms           |
| Minimum Point Isolation  | 1,500 VDC           | n/a                       |
| Nominal Input Impedance  | > 3.0 KΩ            | > 30 KΩ                   |
| Nominal Field Power Load |                     |                           |
| Per On point             | 0.2 watts           | negligible                |
| @ maximum field voltage  | 0.5 watts           | negligible                |
| Diagnostic Indicators    |                     |                           |
| Input Status             | 1 per point         | 1 per point               |
| Module Status            | PASS, FAULT, ACTIVE | PASS, FAULT, ACTIVE       |
| Stuck Test               | On and Off          | On and Off                |
| Color Code               | Dark Red            | Dark Red                  |

a. The voltage is selected using the TriStation 1131 software.

b. Off to On transition is guaranteed at or above this level but it might occur at a lower voltage, depending on the module's hysteresis.

c. On to Off transition is guaranteed at or below this level but it might occur at a higher voltage, depending on the module's hysteresis.

## Pulse Input Module

The Model 3511 Pulse Input (PI) Module provides eight very sensitive, high-frequency inputs. It is optimized for use with non-amplified magnetic speed sensors common on rotating equipment such as turbines or compressors. The module senses voltage transitions from magnetic transducer input devices, accumulating them during a selected window of time (rate measurement). The resulting count is used to generate a frequency or RPM which is transmitted to the Main Processors. The pulse count is measured to 1 micro-second resolution.

The PI module includes three isolated input channels. Each input channel independently processes all data input to the module and passes the data to the Main Processors, which vote on the data to ensure the highest integrity.

Each module provides complete ongoing diagnostics on each channel. Failure of any diagnostic on any channel activates the Fault indicator, which in turn activates the chassis alarm signal. The Fault indicator merely indicates a channel fault, not a module failure. The module is guaranteed to operate properly in the presence of a single fault and may continue to operate properly with certain kinds of multiple faults. The Pulse Input Module supports hot-spare modules.

**WARNING:** *The PI module does not provide a totalization capability—it is optimized for measuring the speed of rotation equipment. For pulse totalization, see Model 3515 on page 44.*

## Relay Output Module

The Model 3636R and 3636T Relay Output (RO) Modules are non-tripli-

cated modules for use on non-critical points which are not compatible with “high-side” solid-state output switches. An example is interfacing with annunciator panels. The Relay Output module receives output signals from the Main Processors on each of three channels. The three sets of signals are then voted, and the voted data is used to drive the 32 individual relays.

Each output has a loopback circuit which verifies the operation of each relay switch independently of the presence of a load, while ongoing diagnostics test the operational status of the module. Failure of any diagnostic activates the Fault indicator, which in turn activates the chassis alarm.

The Relay Output module comes with normally open (NO) contacts. It supports hot-spare modules and requires a separate external termination panel (ETP) with a cable interface to the Tricon controller backplane.

## Pulse Input Module Specifications

| Model Number  | 3511                              |
|---|-----------------------------------|
| Type  | TMR, PI                           |
| Input Signals   | 8, non-commoned                   |
| Resolution  | 16 bits                           |
| Accuracy  | 1,000 Hz to 20,000 Hz, ± 0.01%    |
| Input Characteristics (AC coupled, balanced differential) |                                   |
| Update Rate   | 25 ms, typical                    |
| Impedance (load)  | > 8 KW, 20 KW typical             |
| Common Mode Range   | -100 VDC to +100 VDC peak-to-peak |
| Normal Mode Range   | 1.5 V to 200 V peak-to-peak       |
| Overrange Protection                                      | ±150 VDC, continuous              |
| Hysteresis  | 150 millivolts, typical           |
| Wave Shape  | Sine, square, pulse, etc.         |
| Duty Cycle  | 10% to 90%                        |
| Frequency   | 20 Hz to 20,000 Hz                |
| Current Range   | 0-20 mA (250-ohm shunt)           |
| Diagnostic Indicators (ON=true)                           |                                   |
| Input Status  | 1 per point                       |
| Module Status   | PASS, FAULT, ACTIVE               |
| Color   | Light Purple                      |

## RO Module Specifications

| Model Number               | 3636R/T                             |
|----------------------------|-------------------------------------|
| Type                       | Non-triplicated, RO                 |
| Points                     | 32, non-commoned                    |
| Voltage Range              | 125 VAC/VDC, maximum                |
| Current Load               | 2A, maximum                         |
| Minimum Permissible Load   | 10 mA, 5 VDC                        |
| Switching Power, Resistive | 2,000 V A, 150 watts maximum        |
| Point Isolation            | 1,500 VDC<br>1,900 VDC <sup>a</sup> |
| Fuses                      | 1 per output (2.5A fast-acting)     |
| Diagnostic Indicators      |                                     |
| Output Status              | 1 per point                         |
| Module Status              | PASS, FAULT, ACTIVE                 |
| Output Contact             | Normally Open                       |
| Color Code                 | Silver Blue                         |

a. For 3636T.

# Product Specifications

## Pulse Totalizer Input Module

The Model 3515 Pulse Totalizer Input (PTI) Module provides 32 individual 31-bit counters that operate independently. The counters are used with active-flow sensors or per-unit sensors to measure a quantity (count) which is transmitted to the Main Processors. At the time specified by the control program, the Main Processors clear a single counter or all counters.

The PTI module has three isolated input channels. Each input channel independently processes all input data and passes it to the Main Processors, where it is voted before processing to ensure the highest integrity.

Each PTI module provides complete ongoing diagnostics on each channel, including channel-to-channel count comparison. Failure of any diagnostic on any channel activates the Fault indicator, which in turn activates the

chassis alarm. The Fault indicator points to a channel fault, not a module failure. The PTI module is guaranteed to operate properly in the presence of a single fault, and may continue to operate with certain kinds of multiple faults.

The PTI module can operate with or without a hot-spare module. If you use a hot-spare module, it re-educates all counter values from the active module.

## Pulse Totalizer Input Module Specifications

|  |   |
|--|---|
| <b>Model Number</b>  | <b>3515</b>   |
| Type   | TMR, Pulse Totalizer  |
| Number of Input Signals  | 32, non-commoned  |
| Input Frequency Range  | 0 Hz to 1 KHz   |
| Minimum Input Pulse Width                                      | 300 microseconds  |
| Accuracy   |   |
| Active Module  | ± 2 counts  |
| Hot-spare module (maximum error counts during hot replacement) | 1-10 >= 100 Hz<br>0-1 <= 100 Hz                             |
| Maximum Count  | 2,147,483,647 (2 <sup>31</sup> - 1)                         |
| Counter Overflow (worst case @ 1 KHz)                          | 596 Hours (24 days)   |
| Count Overflow Indication                                      | Count goes to negative integer                              |
| Count Resets   | Individual reset per counter                                |
| Recommended Input Voltage Range                                | 42.5 VDC absolute maximum                                   |
| Count Up Switching Level                                       | Rising edge (Off to On)                                     |
| Switching Voltages   |   |
| Off to On  | 15 VDC typical, 18 VDC worst case                           |
| On to Off  | 8 VDC typical, 6 VDC worst case                             |
| Typical Hysteresis   | 4 VDC   |
| Normal Turn-on Current   | 6mA to 9mA  |
| Count Input Delay  | < 15 ms   |
| Point Isolation (opto-isolated)                                | 1,500 VDC minimum   |
| Diagnostic Indicators  |   |
| On or Off State  | 1 per point   |
| Module Status  | PASS, FAULT, ACTIVE   |
| Logic Power  | < 10 watts  |
| Nominal Field Power Load                                       | 0.5 watts per On point<br>1.5 watts @ maximum field voltage |
| Color Code   | Purple  |

### TMR Digital Output Modules

Each TMR Digital Output (DO) module receives output signals from the Main Processors on each of three channels. Each set of three signals is then voted by special quadruplicated output circuitry on the module. The circuitry produces one voted output signal and passes it to the field termination. The quadruplicated voter circuitry provides multiple redundancy for all critical signal paths, guaranteeing safety and maximum availability.

Each TMR Digital Output Module has a voltage-loopback circuit which verifies the operation of each output switch independently of the presence of a load and determines whether latent faults

exist. Failure of the detected field voltage to match the commanded state of the output point activates the LOAD/FUSE alarm indicator.

In addition, ongoing diagnostics are performed on each channel and circuit of a TMR Digital Output Module. Failure of any diagnostic on any channel activates the Fault indicator, which in turn activates the chassis alarm signal. The Fault indicator merely indicates a channel fault, *not* a module failure. The module is guaranteed to operate properly in the presence of a single fault and may continue to operate properly with certain kinds of multiple faults.

All TMR Digital Output Modules support hot-spare capability, and require a separate external termination panel (ETP) with a cable interface to the Tricon controller backplane. Each module is mechanically keyed to prevent improper installation in a configured chassis.

Digital outputs are designed to source the current to field devices, so field power must be wired to each output point on the field termination.

### 16-Point Digital Output Module Specifications

| Model Number                 | 3601E/3601T                      | 3603B/3603E/3603T                                  | 3607E                              | 3604E                             |
|------------------------------|----------------------------------|--|------------------------------------|-----------------------------------|
| Nominal Voltage              | 115 VAC                          | 120 VDC  | 48 VDC                             | 24 VDC                            |
| Type                         | TMR, DO                          | TMR, DO  | TMR, DO                            | TMR, DO                           |
| Output Signals               | 16, non-commoned                 | 16, commoned (3603E/T)<br>16, non-commoned (3603B) | 16, non-commoned                   | 16, non-commoned                  |
| Voltage Range                | 80-155 VAC                       | 90-150 VDC   | 44-80 VDC                          | 22-45 VDC                         |
| Voltage Drop <sup>a</sup>    | < 3V, typical                    | < 1.5V, typical                                    | < 3V, typical                      | < 4V, typical                     |
| Frequency Range              | 47-63 Hz                         | n/a  | n/a                                | n/a                               |
| Current Ratings, Maximum     | 2A per point<br>12A surge/cycle  | 0.8A per point<br>4A surge/10 ms                   | 1A per point<br>5A surge/10 ms     | 2A per point<br>10A surge/10 ms   |
| Load Leakage                 | 2 mA maximum @ 60 Hz             | 2 mA maximum                                       | 2 mA maximum                       | 2 mA maximum                      |
| Chassis Leakage              | 4 mA maximum @ 60 Hz             | n/a  | n/a                                | n/a                               |
| Fuses (on Field Termination) | 1 per output,<br>3A fast-acting  | 1 per output,<br>1.0A fast-acting                  | 1 per output,<br>1.25A fast-acting | 1 per output,<br>2.5A fast-acting |
| Point Isolation              | 1,500 VDC/ 2500 VDC <sup>b</sup> | 1,500 VDC/ 2500 VDC <sup>c</sup>                   | 1,500 VDC                          | 1,500 VDC                         |
| Diagnostic Indicators        |                                  |  |                                    |                                   |
| On or Off state              | 1 per point                      | 1 per point  | 1 per point                        | 1 per point                       |
| Module Status                | PASS, FAULT, ACTIVE              | PASS, FAULT, ACTIVE                                | PASS, FAULT, ACTIVE                | PASS, FAULT, ACTIVE               |
| Field Alarm                  | LOAD/FUSE                        | LOAD/FUSE  | LOAD/FUSE                          | LOAD/FUSE                         |
| Color Code                   | Green                            | Blue   | Light blue                         | Dark blue                         |

a. **WARNING:** The voltage drop may be significantly higher in some applications.

b. For 3601T.

c. For 3603T.

# Product Specifications

## 16-Point Supervised and 32-Point Supervised/Non-Supervised Digital Output Modules

Designed for the most critical control programs, Supervised Digital Output (SDO) modules meet the needs of systems whose outputs remain in a single state for extended periods of time (in some applications, for years). An SDO module receives output signals from the Main Processors on each of three channels. Each set of three signals is then voted upon by a fully fault-tolerant quadruplicated output switch whose elements are power transistors,

so that one voted output signal is passed to the field termination.

Each SDO module has voltage and current loopback circuitry coupled with sophisticated online diagnostics that verify the operation of each output switch, the field circuit and the presence of a load. This design provides complete fault coverage without the need to influence the output signal.

The modules are called “supervised” because fault coverage is extended to include potential field problems. In other words, the field circuit is *supervised* by the SDO module so that the following field faults can be detected:

- Loss of power or blown fuse
- Open or missing load
- A field short resulting in the load being energized in error
- A shorted load in the de-energized state

Failure to detect field voltage on any output point energizes the power alarm indicator. Failure to detect the presence of a load energizes the load alarm indicator.

All SDO modules support hot-spare modules and require a separate external termination panel (ETP) with a cable interface to the Tricon controller back-plane.

## 16-Point and 32-Point Supervised Digital Output Module Specifications

| Model Number                 | 3623/3623T <sup>a</sup>              | 3624                                   | 3625/3625A <sup>b</sup>              |
|------------------------------|--------------------------------------|--|--------------------------------------|
| Nominal Voltage              | 120 VDC                              | 24 VDC                                 | 24 VDC                               |
| Type                         | TMR, Supervised DO                   | TMR, Supervised DO                     | TMR, Supervised/Non-Supervised DO    |
| Output Signals               | 16, commoned                         | 16, commoned                           | 32, commoned                         |
| Voltage Range                | 90-150 VDC                           | 16-30 VDC                              | 16-32 VDC                            |
| Maximum Voltage              | 160 VDC                              | 36 VDC                                 | 36 VDC                               |
| Voltage Drop                 | < 1.5 VDC, typical                   | < 1.5 VDC, typical                     | < 2.8 VDC @ 1.7A, typical            |
| Power Module Load            | < 10 watts                           | < 10 watts                             | < 13 watts                           |
| Current Ratings, Maximum     | 0.8A per point<br>4A surge per 10 ms | 0.7A per point<br>4.8A surge per 10 ms | 1.7A per point<br>7A surge per 10 ms |
| Minimum Required Load        | 30 mA                                | 30 mA                                  | 10 mA                                |
| Load Leakage                 | 4 mA maximum                         | 4 mA maximum                           | 4 mA maximum                         |
| Fuses (on Field Termination) | 1A fast-acting                       | n/a—self-protecting                    | n/a—self-protecting                  |
| Point Isolation              | 1,500 VDC/ 2500 VDC <sup>c</sup>     | 1,500 VDC                              | 1,500 VDC                            |
| Diagnostic Indicators        |                                      |  |                                      |
| On or Off State              | 1 per point                          | 1 per point                            | 1 per point                          |
| Module Status                | PASS, FAULT, ACTIVE                  | PASS, FAULT, ACTIVE                    | PASS, FAULT, LOAD, ACTIVE            |
| Field Alarm                  | POWER, LOAD (1 per point)            | POWER, LOAD (1 per point)              | LOAD (1 per point)                   |
| Color Code                   | Steel blue                           | Turquoise green                        | Dark blue                            |

a. CAUTION: Invensys highly recommends that you perform compatibility testing before selecting the Model 3623T module for use in applications that have field wiring lengths over 328 feet (100 meters), cable that is not twisted pair, or atypical loads such as smart devices, strobe lights, or klaxons.

b. CAUTION: Invensys highly recommends using a single set of redundant field power supplies for the 3625/3625A termination panels. For the 3625A module, if field power is supplied to the termination panels using four independent power sources, the voltage from all power sources must be maintained within 5% of the highest voltage supplied.

c. For 3623T.

### 8-Point Supervised Digital Output Modules

Designed for the most critical applications, Supervised Digital Output (SDO) modules meet the needs of systems whose outputs remain in a single state for extended periods of time (in some applications, for years). An SDO module receives output signals from the Main Processors on each of three channels. Each set of three signals is then voted upon by a fully fault-tolerant quadruplicated output switch whose elements are mechanical power relays, so that one voted output signal is passed to the field termination.

Each SDO module has voltage and current loopback circuitry coupled with

sophisticated online diagnostics that verify the operation of each output switch, the field circuit and the presence of a load. This design provides complete fault coverage without the need to influence the output signal.

The modules are called “supervised” because fault coverage is extended to include potential field problems. In other words, the field circuit is *supervised* by the SDO module so that the following field faults can be detected:

- Loss of power or blown fuse
- Open or missing load
- A field short resulting in the load being energized in error

- A shorted load in the de-energized state

Failure to detect field voltage on any output point energizes the power alarm indicator. Failure to detect the presence of a load energizes the load alarm indicator. When an optional secondary power supply is used, shorted loads in the Off state can be detected. (This feature is not provided on Model 3611E, an AC module.)

All SDO modules support hot-spare capability, and they require separate external termination panels (ETP) with a cable interface to the Tricon controller backplane.

### 8-Point Supervised Digital Output Module Specifications

| Model Number                            | 3611E                           | 3617E                            |
|---|---------------------------------|----------------------------------|
| Nominal Voltage                         | 115 VAC                         | 48 VDC                           |
| Type                                    | TMR, Supervised DO              | TMR, Supervised DO               |
| Points                                  | 8, commoned                     | 8, commoned                      |
| Voltage Range                           | 90-155 VAC                      | 36-72 VDC                        |
| Frequency Range                         | 47-63 Hz                        | n/a                              |
| Maximum Switching Power                 | 2,000 VA (resistive)            | 150 W (resistive)                |
| On State Voltage Drop <sup>a</sup>      | < 2V, typical                   | < 2V, typical                    |
| Current Ratings, Maximum                | 2A per point<br>10A/AC cycle    | 1A per point<br>5A/10 ms         |
| Minimum Required Load                   | 50 mA                           | 100 mA                           |
| Voltage Range of Secondary Power Supply | n/a                             | 5.00 VDC<br>±.25 VDC             |
| Chassis Leakage                         | 1mA max. @ 60 Hz                | n/a                              |
| Load Leakage                            | 4 mA max.                       | 4 mA max.                        |
| Fuses (on Field Termination)            | 1 per output (2.5A fast-acting) | 1 per output (1.25A fast-acting) |
| Point Isolation                         | 1,500 VDC, min.                 | 1,500 VDC, min.                  |
| Diagnostic Indicators                   |                                 |                                  |
| Output Status                           | POINT, PWR, LOAD,               | POINT, PWR, LOAD,                |
| Module Status                           | PASS, FAULT, ACTIVE             | PASS, FAULT, ACTIVE              |
| Color Code                              | Deep green                      | Mint green                       |

a. **WARNING:** The voltage drop may be significantly higher in some applications.

## Product Specifications

### Dual Digital Output Module

Dual Digital Output (DDO) modules receive output signals from the Main Processors along a single parallel or series path, and applies a 2-out-of-3 voting process individually to each switch. The switches produce one output signal which is then passed to the field termination. While the quadruplicated output circuitry on TMR modules provides multiple redundancy for all critical signal paths, dual circuitry provides just enough redundancy to ensure safe operation. DDO modules are optimized for those safety-critical control programs where low cost is more important than maximum availability.

DDO modules have a voltage-loopback circuit which verifies the operation of

each output switch independently of the presence of a load and determines whether latent faults exist. Failure of the detected field voltage to match the commanded state of the output point activates the LOAD/FUSE alarm indicator.

In addition, ongoing diagnostics are performed on each channel and circuit of a DDO module. Failure of any diagnostic on any channel activates the Fault indicator, which in turn activates the chassis alarm signal. A dual module operates properly in the presence of most single faults and may operate properly with some kinds of multiple faults, but stuck-Off faults are an exception. If one of the output switches has a stuck-Off fault, the output goes to the Off state and a glitch may occur

during switch-over to a hot-spare module.

DDO modules support hot-spare capability, which allows online replacement of a faulty module. Each module is mechanically keyed to prevent improper installation in a configured chassis.

DDO modules require a separate external termination panel (ETP) with a cable interface to the Tricon controller backplane. Digital outputs are designed to source the current to field devices, so field power must be wired to each output point on the field termination.

### Dual Digital Output Module Specifications

| Model Number                 | 3664/3674   |
|------------------------------|---|
| Nominal Voltage              | 24 VDC  |
| Type                         | Dual DO, serial (recommended for de-energize-to-trip control programs)  |
| Output Signals               | 32, commoned  |
| Voltage Range                | 16-30 VDC   |
| Maximum Voltage              | 36 VDC  |
| Voltage Drop                 | < 1.5 VDC, typical  |
| Power Module Load            | < 10 watts  |
| Current Ratings, Maximum     | 2A per point<br>10A surge per 10 ms   |
| Load Leakage                 | 2 mA maximum  |
| Fuses (on Field Termination) | n/a—self-protecting   |
| Point Isolation              | 1,500 VDC minimum   |
| Diagnostic Indicators        |   |
| On or Off State              | 1 per point   |
| Module Status                | PASS, FAULT, ACTIVE   |
| Field Alarm                  | LOAD/FUSE   |
| Load Alarm, output stuck-On  | 3664 — Stuck-On point, all others commanded state - On or Off<br>3674 — Stuck-On point, all others commanded Off (de-energized) |
| Load Alarm, output stuck-Off | 3664 and 3674 — Stuck-Off point, all others commanded state — On or Off   |
| Color Code                   | Dark blue   |

### Analog Input Modules

Analog Input (AI) Modules includes three independent input channels. Each input channel receives variable voltage signals from each point, converts them to digital values, and transmits the values to the three Main Processor modules on demand. In TMR mode, one value is then selected using a mid-value selection algorithm to ensure correct data for every scan.

Sensing of each input point is performed in a manner that prevents a single failure on one channel from

affecting another channel. Each Analog Input Module sustains complete, ongoing diagnostics for each channel. Failure of any diagnostic on any channel activates the Fault indicator for the module, which in turn activates the chassis alarm signal. The module's Fault indicator merely reports a channel fault, *not* a module failure—the module can operate properly with as many as two faulty channels.

Analog Input Modules support hot-spare capability, which allows online replacement of a faulty module.

Analog Input Modules require a separate external termination panel (ETP) with a cable interface to the Tricon controller backplane. Each module is mechanically keyed for proper installation in a Tricon chassis.

### Analog Input Module Specifications

| Model Number               | 3700/3700A                      | 3701                            | 3703E   |
|----------------------------|---------------------------------|---------------------------------|---|
| Voltage                    | 0-5V, + 6% (only 3700A)         | 0-10V                           | 0-5V or 0-10V <sup>a</sup> , + 6%                     |
| Type                       | TMR, AI                         | TMR, AI                         | TMR, AI   |
| No. of Input Points        | 32, diff, DC coupled            | 32, diff, DC coupled            | 16, diff, isolated                                    |
| Isolated Points            | No                              | No                              | Yes   |
| Input Update Rate          | 55 ms                           | 55 ms                           | 50 ms   |
| Resolution                 | 12 bits                         | 12 bits                         | 12 bits   |
| Accuracy                   | < .15% of FSR, from 0° to 60° C | < .15% of FSR, from 0° to 60° C | < .15% of FSR, from 0° to 60° C                       |
| Input Resistance (load)    | 30 MΩ (DC), min.                | 30 MΩ (DC), min.                | 30 MΩ (DC), min.                                      |
| Power-Off Resistance       | 30 KΩ (DC), typical             | 30 KΩ (DC), typical             | 30 MΩ (DC), min.                                      |
| Common Mode Rejection      | -80 dB (DC-100Hz), typical      | -80 dB (DC-100Hz), typical      | -90 dB @ 60Hz, min.<br>-100 dB @ DC, min.             |
| Common Mode Range          | -12V to +12V peak               | -12V to +12V peak               | ±200V peak  |
| Leg-to-Leg Isolation       | 200 KΩ, typical                 | 200 KΩ, typical                 | 20 KΩ, typical  |
| Normal Mode Rejection      |                                 |                                 |   |
| @ 8Hz                      | -3 dB                           | -3 dB                           | -3 dB   |
| @ 60Hz                     | -17 dB                          | -17 dB                          | -17 dB  |
| @ 120Hz                    | -23 dB                          | -23 dB                          | -23 dB  |
| Input Overrange Protection | 150 VDC/115 VAC continuous      | 150 VDC/115 VAC continuous      | 150 VDC/115 VAC continuous                            |
| Current Range              | 0-20 mA,<br>250 Ω shunt         | 0-20 mA,<br>500 Ω shunt         | 0-20 mA,<br>250 Ω shunt for 5V<br>500 Ω shunt for 10V |
| Diagnostic Indicators      |                                 |                                 |   |
| Module Status              | Pass, Fault, Active             | Pass, Fault, Active             | Pass, Fault, Active                                   |
| Color Code                 | Yellow                          | Light yellow                    | Mustard yellow  |

a. The voltage is selected using the TriStation 1131 software.

# Product Specifications

## Analog Input Module Specifications

| Model Number               | 3704E   | 3720  | 3721  |
|----------------------------|---|---|---|
| Voltage                    | 0-5V or 0-10V <sup>a</sup> , + 6%                     | 0-5VDC, + 6%  | 0 to 5 VDC or -5 to +5 VDC <sup>a</sup> , + 6%    |
| Type                       | TMR, AI   | TMR, AI   | TMR, AI   |
| No. of Input Points        | 64, commoned  | 64, single-ended  | 32 differential, DC-coupled                       |
| Isolated Points            | No  | Yes   | Yes   |
| Input Update Rate          | 75 ms   | 10 ms   | 10 ms   |
| Resolution                 | 12 bits   | 12 bits or 14 bits programmable                           | 12 bits or 14 bits programmable                   |
| Accuracy                   | < 0.25% of FSR from 0° to 60° C                       | < 0.15% of FSR from 0° to 60° C                           | < 0.15% of FSR from 0° to 60° C                   |
| Input Resistance (load)    | 30 MΩ (DC), min.                                      | 10 MΩ (DC), min.  | 10 MΩ (DC), min.                                  |
| Power-Off Resistance       | 30 kΩ (DC), typical                                   | 140 kΩ (DC), typical                                      | 140 kΩ (DC), typical                              |
| Common Mode Rejection      | n/a   | n/a   | -85 dB (DC - 100 Hz)                              |
| Common Mode Range          | n/a   | n/a   | -12V to +12V peak                                 |
| Leg-to-Leg Isolation       | 200 kΩ, typical                                       | 420 kΩ, typical   | 420 kΩ, typical                                   |
| Normal Mode Rejection      | -1 dB @ 8Hz<br>-12 dB @ 60Hz<br>-18 dB @ 120Hz        | -3 dB @ 8Hz<br>-17 dB @ 60Hz<br>-23 dB @ 120Hz            | -3 dB @ 23 Hz<br>-8 dB @ 60 Hz<br>-14 dB @ 120 Hz |
| Input Overrange Protection | 150 VDC/115 VAC continuous                            | 150 VDC/115 VAC continuous                                | 150 VDC/115 VAC continuous                        |
| Current Range              | 0-20 mA,<br>250 Ω shunt for 5V<br>500 Ω shunt for 10V | 0-20 mA (plus 6% over-range) with<br>250 Ω shunt resistor | 0-20 mA with 250 Ω shunt resistor                 |
| Diagnostic Indicators      |   |   |   |
| Module Status              | PASS, FAULT, ACTIVE                                   | PASS, FAULT, ACTIVE, FIELD                                | PASS, FAULT, ACTIVE, FIELD                        |
| Color Code                 | Copper  | Yellow  | Yellow  |

a. The voltage is selected using the TriStation 1131 software.

## Analog Output Modules

Analog Output (AO) modules receive output signals from the Main Processor module on each of three channels. Each set of data is then voted and a healthy channel is selected to drive the outputs. Each module monitors its own current outputs (as input voltages) and maintains an internal voltage reference to provide self-calibration and module health information.

Each channel on a module has a current loopback circuit which verifies the accuracy and presence of analog signals independently of load presence or channel selection. The module's design prevents a non-selected channel from driving an analog signal to the

field. In addition, ongoing diagnostics are performed on each channel and circuit of the module. Failure of any diagnostic test deactivates the faulty channel and activates the Fault indicator and the chassis alarm. The module Fault indicator merely indicates a channel fault, not a module failure. The module continues to operate properly with as many as two channels failed. Open loop detection is provided by a LOAD indicator which activates if the module is unable to drive current to one or more outputs.

The module provides for redundant loop power sources with individual power and fuse indicators called PWR1 and PWR2. External loop power

supplies for analog outputs must be provided by the user. A LOAD indicator activates if an open loop is detected on one or more output points. PWR1 and PWR2 are on if loop power is present.

AO modules support hot- spare capability, which allows online replacement of a faulty module.

AO modules require a separate external termination panel (ETP) with a cable interface to the Tricon controller backplane. Each module is mechanically keyed to prevent improper installation in a configured chassis.

The Model 3805H module has been modified to support increased inductive loads. It is fully compatible for use in all applications of the 3805E module.

The Model 3806E and Model 3807 modules are optimized for turbomachinery control.

The Model 3806E High Current AO Module has two 20 to 320 mA outputs to drive servo actuators.

The Model 3807 Bipolar AO Module has four -60 to +60 mA outputs to drive servo coils in servo-control applications. The termination panel for the

Model 3807 contains four hard-wired coil diagnostic inputs. The Model 3807 is designed for control applications only, and should not be used in safety applications.

### Analog Output Module Specifications

| Model Number                                    | 3805E/3805H   | 3806E  | 3807   |   |
|---|---|--|--|---|
| Type  | TMR, AO   | TMR, AO  | TMR, AO  |   |
| Output current range                            | 4-20 mA output (+6% overrange)  | 4-20 mA and 20-320 mA  | -60 to 60 mA   |   |
| Number of points                                | 8 output  | 6 (4-20 mA) output; 2 (20-320 mA) output   | 4 bipolar output   |   |
| Isolated points                                 | No, commoned return, DC coupled   | No, commoned return, DC coupled  | No, commoned return, DC coupled  |   |
| Resolution                                      | 12 bits   | 12 bits  | 13 bits  |   |
| Output Accuracy                                 | <0.25% (in range of 4-20 mA) of FSR (0-21.2 mA), from 32° to 140° F (0° to 60° C) | <0.25% (in range of 4-20 mA) of FSR (0-21.2 mA and 0-339.2 mA), from 32° to 140° F (0° to 60° C) | <0.25% (in range of -60 to 60 mA) of Full Scale Range (FSR), from 0° to 60° C. FSR = 120 mA. |   |
| External loop power (reverse voltage protected) | +42.5 VDC, maximum<br>+24 VDC, nominal  | +42.5 VDC, maximum<br>+24 VDC, nominal   | 24 VDC -15%/+20%, +5% ripple   |   |
| Output loop power requirements                  |   | <u>Max. load vs. external loop voltage</u>   |  |   |
| <u>Load (Ohms)</u>                              | <u>Loop power required</u>  | <u>4-20 mA</u>   | <u>16-320 mA</u>   | Compliance voltage is ± 9V and is independent of variations in external loop power supply voltage<br>150 ohm @ ± 60 mA<br>1 kohm @ ± 9 mA<br>9 kohm @ ± 1 mA. |
| 250   | > 20 VDC (1 amp minimum)  | 20 VDC ≤ 275   | ≤ 15   |   |
| 500   | > 25 VDC (1 amp minimum)  | 24 VDC ≤ 475   | ≤ 25   |   |
| 750   | > 30 VDC (1 amp minimum)  | 28 VDC ≤ 650   | ≤ 40   |   |
| 1000  | > 35 VDC (1 amp minimum)  | 32 VDC ≤ 825   | ≤ 50   |   |
| Over-range protection                           | +42.5 VDC, continuous   | < +42.5 VDC  | +36 VDC, continuous  |   |
| Switch time on leg failure                      | < 10 ms, typical  | < 10 ms, typical   | < 10 ms, typical   |   |
| Diagnostic Indicators                           |   |  |  |   |
| Module status (one each per module)             | PASS, FAULT, ACTIVE, LOAD, PWR1, PWR2   | PASS, FAULT, ACTIVE, LOAD, PWR1, PWR2  | PASS, FAULT, ACTIVE, LOAD, PWR1, PWR2  |   |
| Color code                                      | Pea green   | Light green  | Light green  |   |

# Product Specifications

## Thermocouple Input Modules

Thermocouple Input (TC) modules include three independent input channels. Each input channel receives variable voltage signals from each point, performs thermocouple linearization and cold-junction compensation, and converts the result to degrees Celsius or Fahrenheit. Each channel then transmits 16-bit signed integers representing 0.125 degrees per count to the three Main Processors on demand. In TMR mode, a value is then selected using a mid-value selection algorithm to ensure correct data for every scan.

Each Thermocouple Input Module is programmable to support one thermocouple type, selected from J, K and T for standard Thermocouple Input Modules and from J, K, T, and E for

isolated Thermocouple Input Modules. The isolated module allows users to select upscale or downscale burnout detection with the TriStation 1131 software. For non-isolated modules, upscale or downscale burnout detection depends on the field termination selected.

Triplicated temperature transducers residing on the field termination panel support cold-junction compensation. Each channel of a Thermocouple Input Module performs auto-calibration using internal precision voltage references. On the isolated module, a faulting cold-junction transducer is annunciated by a cold-junction indicator on the front panel.

Each module performs complete ongoing diagnostics on each channel.

Failure of any diagnostic on any channel activates the Fault indicator, which in turn activates the chassis alarm signal. The module Fault indicator merely reports a channel fault, not a module failure. The module continues to operate properly with as many as two faulty channels.

Thermocouple Input Modules support hot-spare capability, which allows online replacement of a faulty module. Thermocouple Input Modules require a separate external termination panel (ETP) with a cable interface to the Tricon controller backplane.

Each module is mechanically keyed to prevent improper installation in a configured chassis.

## Thermocouple Input Module Specifications

| Model Number                              | 3706A  | 3708E   |
|---|--|---|
| Type                                      | TMR, thermocouple                                      | TMR, thermocouple                                       |
| Number of input signals                   | 32 differential, DC coupled                            | 16 differential, isolated                               |
| Isolated points                           | No   | Yes   |
| Input update rate                         | 50 ms, maximum <sup>a</sup>                            | 50 ms   |
| Thermocouple types supported <sup>b</sup> | J, K, T  | J, K, T, E  |
| Accuracy/temp range                       | See Table A  | See Table B   |
| Input resistance (load)                   | 22 MΩ (DC), typical                                    | 30 MΩ (DC), minimum                                     |
| Noise rejection                           |  |   |
| Common mode                               | -85 dB @ 0-60 Hz, minimum<br>-95 dB @ DC, typical      | -90 dB @ 0-60 Hz, minimum<br>-100 dB @ DC, minimum      |
| Normal mode                               | -17 dB @ 60 Hz   | -3 dB @ 8 Hz, typical<br>-17 dB @ 60 Hz, typical        |
| Common mode range                         | ±10 VDC max. (channel-to-channel or channel-to-ground) | ±200 VDC, max (channel-to-channel or channel-to-ground) |
| Leg-to-leg isolation                      | 200 KΩ, typical  | 20 KΩ, typical  |
| Input point protection                    | 110 VAC, continuous                                    | 110 VAC, continuous                                     |
| Reference junction compensation range     | 32°-140° F (0°-60° C)                                  | 32°-140° F (0°-60° C)                                   |
| Diagnostic indicators                     | PASS, FAULT, ACTIVE                                    | PASS, FAULT, ACTIVE, CJ FAULT                           |
| Color code                                | Tan  | Deep yellow   |

a. Inputs frozen for one second upon insertion of spare module.

b. Selected using the TriStation 1131 software.

**Accuracy of Thermocouple Types for Model 3706A**

| TC Type | Temperature Range             | Accuracy <sup>a</sup><br>(TC Termination Module @ 32-140° F [0-60° C]) |   |
|---------|-------------------------------|--|---|
|         |                               | T <sub>a</sub> = 77° F (25° C)<br>(Typical)                            | T <sub>a</sub> = 32-140° F (0-60° C)<br>(Maximum) |
| J       | -250 to 32° F (-157 to 0° C)  | ± 5.0° F (2.8° C)  | ± 7.0° F (3.9° C)                                 |
|         | >32 to 2000° F (0 to 1093° C) | ± 4.0° F (2.3° C)  | ± 5.0° F (2.8° C)                                 |
| K       | -250 to 32° F (-157 to 0° C)  | ± 6.0° F (3.4° C)  | ± 9.0° F (5.0° C)                                 |
|         | >32 to 2500° F (0 to 1371° C) | ± 4.0° F (2.3° C)  | ± 6.0° F (3.4° C)                                 |
| T       | -250 to 32° F (-157 to 0° C)  | ± 5.0° F (2.8° C)  | ± 9.0° F (5.0° C)                                 |
|         | >32 to 752° F (0 to 400° C)   | ± 3.0° F (1.7° C)  | ± 5.0° F (2.8° C)                                 |

**Accuracy of Thermocouple Types for Model 3708E**

| TC Type | Temperature Range             | Accuracy <sup>a</sup><br>(TC Termination Module @ 32-140° F [0-60° C]) |   |
|---------|-------------------------------|--|---|
|         |                               | T <sub>a</sub> = 77° F (25° C)<br>(Typical)                            | T <sub>a</sub> = 32-140° F (0-60° C)<br>(Maximum) |
| J       | -238 to 32° F (-150 to 0° C)  | ± 3.0° F (1.7° C)  | ± 9.0° F (5.0° C)                                 |
|         | >32 to 1400° F (0 to 760° C)  |  | ± 5.5° F (3.1° C)                                 |
| K       | -238 to 32° F (-150 to 0° C)  | ± 4.0° F (2.3° C)  | ± 8.0° F (4.5° C)                                 |
|         | >32 to 2284° F (0 to 1370° C) |  | ± 7.0° F (3.9° C)                                 |
| T       | -250 to 32° F (-161 to 0° C)  | ± 3.0° F (1.7° C)  | ± 8.5° F (4.8° C)                                 |
|         | >32 to 752° F (0 to 400° C)   |  | ± 4.5° F (2.5° C)                                 |
| E       | -328 to 32° F (-200 to 0° C)  | ± 3.0° F (1.7° C)  | ± 8.0° F (4.5° C)                                 |
|         | >32 to 1830° F (0 to 999° C)  |  | ± 5.0° F (2.8° C)                                 |

a. Accuracy specifications account for errors related to reference-junction compensation, but do not account for errors caused by temperature gradients between the temperature transducers and the TC terminations. The user is responsible for maintaining a uniform temperature across the TC Termination Module.

# Product Specifications

## HART Interface Modules

Highway Addressable Remote Transducer (HART) is an industry standard field bus protocol that superimposes a Frequency Key Shifted (FSK) signal onto the 4-20 mA loop. The Tricon Model 2071H HART Multiplexer Module that is incorporated into each of the HART Interface Modules capacitively couples the HART signal to the AI or AO signals. The HART signals are approximately ±0.5 mA at 1,200

and 2,200 Hz. These frequencies are high enough that the low-bandwidth loop is unaffected and the HART electronics can impose and extract the HART signals easily.

HART communication through the HART multiplexer is separate from the Tricon system and is certified not to interfere with the 4-20 mA safety signals of the Analog Input and Analog Output Modules.

Only Tricon v10.4.x and later systems can use HART Interface Modules; earlier Tricon systems must upgrade to Tricon v10.4.x. The chassis requirements for using HART Interface Modules in a system upgraded to Tricon v10.4.x differ depending on the original system version, as described in the Tricon Chassis Usage for HART Communication table.

## HART Interface Module Specifications

| Model Number                      | 2770H   | 2870H   |
|-----------------------------------|---|---|
| Type                              | HART Analog Input Interface                         | HART Analog Output Interface                        |
| Compatible Modules                | 3700A, 3721   | 3805E, 3805H  |
| Number of signals                 | 32 input  | 8 output  |
| Input/Output type                 | 4-20 mA, 0-5 VDC input                              | 4-20 mA, 0-5 VDC output                             |
| HART MUX module                   | 2071H (includes the Triconex 4850 HART Multiplexer) | 2071H (includes the Triconex 4850 HART Multiplexer) |
| Status indicator: HART MUX module | PWR, FAULT, HOST, HART                              | PWR, FAULT, HOST, HART                              |
| HART protocol                     | HART Field Communication Protocol, Revision 5.0-7.0 | HART Field Communication Protocol, Revision 5.0-7.0 |
| Logic power                       | < 5 Watts   | < 5 Watts   |

## Tricon Chassis Usage for HART Communication

| If Your Original System Version is...  | Upgrade to...  | Install HART Interface Modules in Chassis...   |
|--|----------------|--|
| Tricon v10.4.x or later (High-Density) | n/a            | <ul style="list-style-type: none"> <li>Model 8121 Enhanced Low-Density Expansion Chassis</li> </ul>  |
| Tricon v10.0.x – 10.3.x (High-Density) | Tricon v10.4.x | <ul style="list-style-type: none"> <li>Model 8121 Enhanced Low-Density Expansion Chassis</li> </ul>  |
| Tricon v9.x (High-Density)             | Tricon v10.4.x | <ul style="list-style-type: none"> <li>Model 8121 Enhanced Low-Density Expansion Chassis</li> </ul>  |
| Tricon v6.x – v10.x (Low-Density)      | Tricon v10.4.x | <ul style="list-style-type: none"> <li>Model 8100-x Main Chassis</li> <li>Model 8101 Low-Density Expansion Chassis</li> <li>Model 8102 Low-Density RXM Chassis</li> <li>Model 8121 Enhanced Low-Density Expansion Chassis</li> </ul> |

*A termination panel and associated cable pass signals to or from the field, permitting replacement of I/O Modules without disturbing field wiring.*

## Field Termination Options

There are two general types of field termination products available from Invensys:

- External termination panels
- Cables

All termination panels and cables are built to withstand harsh industrial environments. The environmental specifications for components used on these products are the same as for a Tricon chassis. (See “General Environmental and EMC Specifications” on page 27 for details.)

### External Termination Panels

An external termination panel (ETP) is an electrically-passive printed circuit board (PCB) to which field wiring is easily attached. A panel connector, terminal blocks and various components are mounted to the PCB and enclosed in a plastic housing. A termination panel and associated cable pass input signals from the field directly to an input module, or pass output signals from an output module directly to field wiring. This arrangement permits the removal or replacement of I/O modules without disturbing field wiring.

External termination panels allow you to marshal field signals in a separate enclosure up to 99 feet (30 meters) from a Tricon chassis.

Standard termination panels are best for remote marshaling of field wiring where maximum flexibility, high density and simple maintenance is desired.

A standard termination panel consists of a PCB with all necessary components—such as two-piece terminal blocks, resistors, fuses and blown-fuse indicators—mounted on a DIN rail-compatible plastic housing. The housing snaps into mounting rails in accordance with DIN 50 022.

Compression terminals on the standard panel are designed for use with 24- to 12-gauge (0.3 mm<sup>2</sup> to 2.1 mm<sup>2</sup>) wiring. Some panels have an optional current-limiting series resistor, others have a fuse with a blown-fuse indicator, to protect the field wiring and field device.

Standard termination panels are pre-configured for specific applications. For instance, the thermocouple input termination panel provides cold-junction temperature sensors and can be ordered with upscale, downscale or programmable burnout detection. A standard termination panel for analog voltage inputs provides commoned signal returns, while the current-mode version has a precision resistor at each input point to convert current to voltage.

Each standard termination panel is packaged with a matched interface

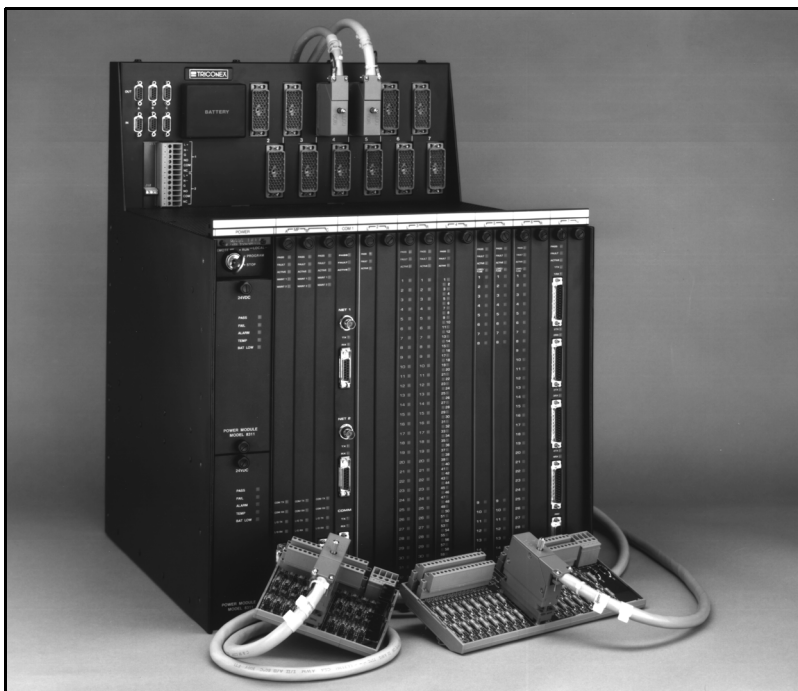

**Tricon Chassis with External Termination Panels and Standard 10' Cables**

## Field Termination Options

cable that connects the panel to the backplane of a Tricon chassis. A female connector at one end of the cable is keyed to match the male connector on the Tricon controller backplane. A male connector on the other end of the cable attaches to the standard termination panel. Two types of cables are available—one that exits the Tricon controller backplane at a ninety-degree angle and one that exits at a zero-degree angle (straight, front-entry).

External termination panel model numbers that end with a “Z” contain zero-degree interface cables. Model numbers for ninety-degree configurations are referenced throughout this guide. It is implied that where a model number is referenced for a ninety-degree configuration, a zero-degree configuration also is available.

Zero-degree cables are designed to be used with G-Series Enclosures for Tricon controllers that have front access. For more information on G-Series Enclosures for Tricon Systems, see the G-Series Enclosures Product Specification Sheet, PSS Number: PSS 21H-2X8 B3, on the Invensys Global

Customer Support (GCS) website at <http://support.ips.invensys.com>.

In addition to standard termination panels, there are other types of termination panels, including:

- Basic termination panels
- Hazardous location (nonincendive) termination panels
- Termination panels with interposing relays
- Bypass panels for digital inputs
- Termination panels with RTD/TC/AI input signal conditioning
- Termination panels for 3603B digital output modules
- Termination panels for 3806E analog output modules

### Basic Termination Panels

Basic termination panels are a low-cost means of connecting field wiring to a Tricon controller. However, basic termination panels do not provide any components other than a 56-pin connector and terminal blocks. These two components are mounted on a DIN rail-compatible plastic housing that

snaps into mounting rails in accordance with DIN 50 022. The user must provide any other components required by his application.

Other features of the basic termination panels are the same as for the standard panels.

### Hazardous Location (Nonincendive) Termination Panels

Hazardous location (nonincendive) termination panels are suitable for use in Zone 2 (ATEX), and Class 1, Division 2 (North America) field circuits. These panels contain extra circuitry designed to limit power available to the field terminals and have been examined and certified by TÜV Rheinland as being nonincendive. This guarantees that if the field wires are accidentally opened, shorted, or grounded, and the Tricon controller is operating normally, the wiring and attached devices will not release sufficient energy to cause ignition in the specified flammable atmosphere.

### Termination Panels with Interposing Relays

Interposing relays are recommended for applications that have load currents greater than 2 amps, or field voltages greater than 115 VAC which require field-circuit conversion or compatibility with motor-starter circuits.

Each interposing relay provides an auxiliary contact that can be connected to a digital input module by means of an optional loopback cable to verify relay activation by the digital output module. Interposing relay panels use compact general-purpose power relays for maximum reliability and can be used with most digital output modules.

### Bypass Panels for Digital Inputs

Bypass termination panels can be used to connect digital inputs using a bank of 32 pre-wired switches. The bypass

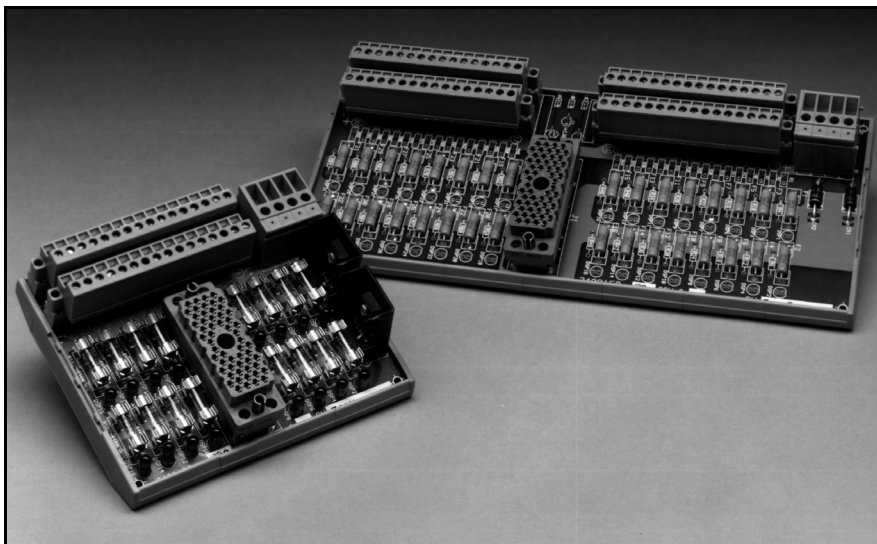

Standard Termination Panels in 16-Point and 32-Point Styles

panel has a master keyswitch and terminals for redundant +24 VDC power sources. Each input point contains an On status indicator and a position for a user-defined label. Each bypass termination panel comes with one or two 10-foot cables for connecting the termination panel to a Tricon controller backplane.

### Termination Panels for Use with Signal Conditioners

Termination panels which use industry-standard analog signal conditioners provide a flexible, user-configurable interface to resistive thermal devices (RTDs), thermocouples, and 4-20 mA transmitters. Each termination panel supports 16 points and each analog module can support up to 2 panels.

These termination panels are compatible with any signal conditioners in the 1 to 5 volt output range. For example, the 7B series of signal conditioners from Analog Devices are known to work well.

These signal conditioners can be purchased from Invensys, or directly from Analog Devices at:

- <http://www.analog.com/IOS>
- 1-800-426-2564 in the USA
- 781-461-3100 from anywhere in the world

### Fanned-Out Cables

Fanned-out cables are a low-cost alternative to using external termination panels. Fanned-out cables allow you to marshal field signals in a separate enclosure up to 99 feet (30 meters) from a Tricon chassis. One end of a fanned-out cable has a female connector that connects to a Tricon chassis backplane. The other end of the cable contains 50 fanned-out leads, each individually labeled with its corresponding connector pin number.

Each fanned-out cable has the following characteristics:

- PVC outer covering
- 56-pin connector at one end
- 50 stranded, stripped, tinned and labeled 22-gauge leads at opposite end

Fanned-out cables should only be used with digital input and digital output modules. They are not certified for use with analog signals. Contact the Invensys Global Customer Support (GCS) center if you need a fanned-out cable for handling analog signals.

Although the normal length of all cables is 10 feet (3 meters), any length cable can be ordered up to 99 feet (30 meters) in 10-foot increments, using the last two digits of the cable model number to specify the length in feet. For example, the model number 9101-050F specifies a 50-foot cable instead of the normal 10-foot cable.

### Termination Configuration Options

Terminations are available in various factory configurations:

- *Non-commoned* Terminations can accommodate individual power supplies for each point.
- *Commoned* Terminations can support one power supply which is shared by multiple points. Points can be commoned in groups of 8 and groups of 16.
- Analog signals can be read as *3-wire transmitter inputs*, *voltage inputs* or *current inputs*.
- Thermocouple terminations provide cold-junction temperature sensors and are available for either *upscale* or *downscale burnout detection*. For Model 3706A, upscale or downscale burnout detection depends on which

termination panel is installed. For Model 3708E, upscale or downscale burnout detection is configured with the TriStation 1131 software.

The “Termination Options” table (on the next two pages) shows the available termination choices for each I/O module and gives the correct model number for each choice.

### Over-Current Protection

Non-basic termination panels offer over-current protection in various ways:

- Fuses for individual points and/or field power sources
- Series resistors
- Self-protection for digital output and analog output modules

If you are using basic termination panels, you must supply your own components for over-current protection.

### Termination Products for Use in 1E (Safety-Related) Applications in Nuclear Power Plants

For a list of Tricon v10 termination products qualified for use in 1E (safety-related) applications in nuclear power plants, see “Tricon v10.x Equipment Certified for Use in Nuclear 1E Applications” on page 23.

Match your I/O module number in the first column with termination options on the right. An I/O module can be wired to a maximum of two termination panels, which may be of two different types—for example, commoned and non-commoned.

| Module Model # | Module Description                       | Commoned Term Panels                             | Non-Common. Term Panels | Basic Term Panels                | Nonincendive Term Panels | RG 1.180 Term Panels | Fanned-out Cables | Bypass Panels      | ERT Loop-Back Cables/Panels |
|----------------|--|--|-------------------------|----------------------------------|--------------------------|----------------------|-------------------|--------------------|-----------------------------|
| 3501E<br>3501T | DI, 115 VAC/VDC, 32 pts.                 | 9561-810F  | 9561-110F               | 9551-110F                        | n/a                      | n/a                  | 9101-010F         | n/a                | 9141-010F                   |
| 3502E          | DI, 48 VAC/VDC, 32 pts.                  | 9562-810F  | n/a                     | 9552-610F                        | n/a                      | n/a                  | 9101-010F         | n/a                | 9142-010F                   |
| 3503E          | DI, 24 VAC/VDC, 32 pts.                  | 9563-810F<br>9563-910F                           | n/a                     | 9553-610F                        | 9572-610F                | n/a                  | 9101-010F         | BP9228-010F        | 9143-010F                   |
| 3504E          | DI, 24/48 VDC, non-isolated, 64 pts.     | 9566-810F, 24V<br>9565-810F, 48V                 | n/a                     | 9750-310F, 24V<br>9750-410F, 48V | 9570-610F, 24V<br>n/a    | n/a                  | n/a               | BP9229-010F<br>n/a | n/a                         |
| 3505E          | DI, 24 VDC, low threshold, 32 pts.       | 9563-810F<br>9563-910F                           | n/a                     | 9553-610F                        | 9572-610F                | n/a                  | 9101-010F         | BP9228-010F        | 9143-010F                   |
| 3510           | PI, 20-20,000 Hz, 8 pts.                 | n/a  | n/a                     | 9753-110F                        | n/a                      | n/a                  | n/a               | n/a                | n/a                         |
| 3511           | PI, 20-20,000 Hz, 8 pts.                 | n/a  | n/a                     | 9753-110F                        | 9793-110F                | 9794-110F            | n/a               | n/a                | n/a                         |
| 3515           | Pulse totalizer, 24 VDC, 32 pts.         | n/a  | n/a                     | 9753-110F                        | 9572-610F                | n/a                  | n/a               | n/a                | n/a                         |
| 3564           | DI, 24 VDC, single, 64 pts.              | 9566-710F  | n/a                     | 9553-610F                        | 9571-610F                | n/a                  | 9101-010F         | n/a                | n/a                         |
| 3601E          | DO, 115 VAC, 16 pts.                     | 9661-610F<br>9663-610F                           | 9661-110F<br>9664-110F  | 9651-110F                        | n/a                      | n/a                  | 9101-010F         | n/a                | 9670-110F<br>9670-610F      |
| 3601T          | DO, 115 VAC, 16 pts.                     | 9663-610F  | 9664-110F               | n/a                              | n/a                      | n/a                  | n/a               | n/a                | n/a                         |
| 3603B          | DO, 120 VDC, 16 pts.                     | n/a  | 9251-210                | n/a                              | n/a                      | n/a                  | n/a               | n/a                | n/a                         |
| 3603E          | DO, 120 VDC, 16 pts.                     | 9661-910F <sup>a</sup><br>9664-810F <sup>a</sup> | n/a                     | 9651-110F                        | n/a                      | n/a                  | 9101-010F         | n/a                | 9673-810F <sup>a</sup>      |
| 3603T          | DO, 120 VDC, 16 pts.                     | 9664-810F <sup>a</sup>                           | n/a                     | n/a                              | n/a                      | n/a                  | n/a               | n/a                | 9673-810F <sup>a</sup>      |
| 3604E          | DO, 24 VDC, 16 pts.                      | 9662-810F  | 9662-110F               | 9653-610F                        | 9671-610F                | n/a                  | 9101-010F         | n/a                | 9671-810F                   |
| 3607E          | DO, 48 VDC, 16 pts.                      | 9667-810F  | 9667-110F               | 9652-610F                        | n/a                      | n/a                  | 9101-010F         | n/a                | 9672-810F                   |
| 3611E          | DO, 115 VAC, 8 pts.                      | 9661-510F  | n/a                     | n/a                              | n/a                      | n/a                  | n/a               | n/a                | n/a                         |
| 3613E          | DO, 120 VDC, 8 pts.                      | 9661-810F  | n/a                     | n/a                              | n/a                      | n/a                  | n/a               | n/a                | n/a                         |
| 3614E          | DO, 24 VDC, 8 pts.                       | 9662-910F  | n/a                     | n/a                              | n/a                      | n/a                  | n/a               | n/a                | n/a                         |
| 3615E          | DO, 24 VDC, low power, 8 pts.            | 9662-710F  | n/a                     | n/a                              | n/a                      | n/a                  | n/a               | n/a                | n/a                         |
| 3617E          | DO, 48 VDC, 8 pts.                       | 9667-910F  | n/a                     | n/a                              | n/a                      | n/a                  | n/a               | n/a                | n/a                         |
| 3623           | DO, 120 VDC, 16 pts.                     | 9661-910F  | n/a                     | 9651-110F                        | n/a                      | n/a                  | 9101-010F         | n/a                | n/a                         |
| 3623T          | DO, 120 VDC, 16 pts.                     | 9664-810F  | n/a                     | n/a                              | n/a                      | n/a                  | n/a               | n/a                | n/a                         |
| 3624           | DO, 24 VDC, self-protected, 16 pts.      | 9662-610F  | n/a                     | 9653-610F                        | 9671-610F                | n/a                  | 9101-010F         | n/a                | n/a                         |
| 3625<br>3625A  | DO, 24 VDC, self-protected, 32 pts.      | 9662-610F  | n/a                     | 9653-610F                        | 9671-610F                | n/a                  | 9101-010F         | n/a                | 9671-810F <sup>b</sup>      |
| 3636R<br>3636T | Relay output (non-triplicated), 32 pts.  | n/a  | 9668-110F               | 9651-110F                        | n/a                      | n/a                  | 9101-010F         | n/a                | n/a                         |
| 3664           | Dual DO, 24 VDC, self-protected, 32 pts. | 9662-610F  | n/a                     | 9653-610F                        | 9671-610F                | n/a                  | 9101-010F         | n/a                | 9671-810F <sup>b</sup>      |

| 3674               | Dual DO, 24 VDC, self-protected, 32 pts.                | 9662-610F            | n/a                     | 9653-610F   | 9671-610F  | n/a   | 9101-010F                                   | n/a                    | 9671-810F <sup>b</sup>      |
|--------------------|---|----------------------|-------------------------|---|--|---|---|------------------------|-----------------------------|
| Module Model #     | Module Description                                      | Commoned Term Panels | Non-Common. Term Panels | Basic Term Panels   | Nonincendive Term Panels                             | RG 1.180 Term Panels  | Fanned-out Cables                           | Bypass Panels          | ERT Loop-Back Cables/Panels |
| 3805E<br>3805H     | AO, 4–20 mA, 8 pts.                                     | n/a                  | n/a                     | 9853-610F   | 9861-610F  | 9860-610F   | n/a   | n/a                    | n/a                         |
| 2870H              | AO HART Interface                                       | n/a                  | n/a                     | 9853-610F   | 9861-610F  | 9860-610F   | n/a   | n/a                    | n/a                         |
| 3806E              | AO, 6 4–20 mA outputs, 2 20–320 mA outputs              | n/a                  | n/a                     | 9863-710F (special panel)                                 | n/a  | n/a   | n/a   | n/a                    | n/a                         |
| 3807               | AO, 4 bipolar -60 to 60 mA outputs                      | 9881-810F            | n/a                     | n/a   | 9871-810F  | n/a   | n/a   | n/a                    | n/a                         |
| Module Model #     | Module Description                                      | Upscale              | Downscale               | Basic Term Panels   | Nonincendive Term Panels                             | RG 1.180 Term Panels  | Fanned-out Cables                           | Bypass Panels          | ERT Loop-Back Cables/Panels |
| 3706A              | Thermocouple input, type J, K, T, differential, 32 pts. | 9766-210F            | 9766-510F               | n/a   | 9784-610F, upscale<br>9785-610F, downscale           | n/a   | n/a   | n/a                    | n/a                         |
| 3708E              | Thermocouple input, type E, J, K, T, isolated, 16 pts.  | 9765-610F            | 9765-610F               | n/a   | 9786-110F  | 9782-110F   | n/a   | n/a                    | n/a                         |
| Module Model #     | Module Description                                      | 3-Wire 4-20 mA       | Voltage                 | 2-Wire 4-20 mA  | Nonincendive Term Panels                             | RG 1.180 Term Panels  | Basic                                       | RTD/TC/AI              |                             |
| 3700<br>3700A      | AI, 0–5 VDC, differential, 32 pts.                      | n/a                  | 9763-810F               | 9761-210F, 0–5 V<br>9771-210F, 0–5 V                      | 9791-610F, current input<br>9787-110F, voltage input | 9790-610F, current input<br>9792-610F, 4-20 mA, 0-5 V,<br>16 VDC-56 VDC field<br>9783-110F, voltage input<br>9764-310F, RTD/TC/AI input <sup>c</sup>                                | 9753-110F, 0–5 V                            | 9764-310F <sup>c</sup> |                             |
| 2770H              | AI HART Interface                                       | n/a                  | n/a                     | 9761-210F, 0–5 V<br>9771-210F, 0–5 V                      | 9791-610F, current input                             | 9790-610F, current input  | n/a   | n/a                    |                             |
| 3701               | AI, 0–10 VDC, differential, 32 pts.                     | n/a                  | 9763-810F               | 9761-410F   | n/a  | n/a   | 9753-110F, 0–10 V                           | n/a                    |                             |
| 3703E <sup>d</sup> | AI, 0–5/0–10 VDC, isolated, 16 pts.                     | n/a                  | 9763-810F               | 9762-210F, 0–5 V<br>9762-410F, 0–10 V<br>9771-210F, 0-5 V | 9791-610F, current input<br>9787-110F, voltage input | 9790-610F, 4–20 mA, 0–5 V<br>9792-610F, 4-20 mA, 0-5 V,<br>16 VDC-56 VDC field<br>9795-610F, 4–20 mA, 0–10 V<br>9783-110F, voltage input  | 9753-110F, 0–5/0–10 V                       | n/a                    |                             |
| 3704E <sup>d</sup> | AI, 0–5/0–10 VDC, non-isolated, 64 pts.                 | 9765-210F, 0–5V      | n/a                     | 9760-210F, 0–5 V<br>9760-410F, 0–10 V                     | 9789-610F, 4–20 mA                                   | n/a   | 9750-210F, 4–20 mA<br>9750-810F, 0–5/0–10 V | n/a                    |                             |
| 3720               | AI, 0–5 VDC, single-ended, 64 pts.                      | 9765-210F, 0–5 V     | n/a                     | 9760-210F, 0–5 V  | 9789-610F, 4–20 mA                                   | n/a   | 9750-210F, 4–20 mA<br>9750-810F, 0–5 V      | n/a                    |                             |
| 3721 <sup>d</sup>  | AI, 0 to 5 VDC or –5 to +5 VDC, differential, 32 pts.   | n/a                  | 9763-810F               | 9761-210F, 0–5 V<br>9761-410F, 0–10 V<br>9771-210F, 0–5 V | 9791-610F, current input<br>9787-110F, voltage input | 9790-610F, 4–20 mA, 0–5 V<br>9792-610F, 4-20 mA, 0-5 V,<br>16 VDC-56 VDC field<br>9795-610F, 4–20 mA, 0–10 V<br>9783-110F, voltage input<br>9764-310F, RTD/TC/AI input <sup>c</sup> | 9753-110F, 0–5 V                            | 9764-310F <sup>c</sup> |                             |

a. Point blown-fuse indicator will not illuminate when point fuse is removed. Each point is commoned.

b. Point blown-fuse indicator will not illuminate when point fuse is removed. Each point is self-protected and commoned.

c. Signal conditioners must be ordered separately. A total of 16 is required for each termination panel.

d. Must be configured using the TriStation 1131 software.

## Field Termination Options

### Dimensions of External Termination Panels

| Panel Model | Width<br>(across DIN rail) | Length<br>(along DIN rail) | Height<br>(out from DIN rail) |
|-------------|----------------------------|----------------------------|-------------------------------|
| 9251-210F   | 7 in (17.78 cm)            | 19 in (48.26 cm)           | 4.75 in (12.065 cm)           |
| 9551-110F   | 3 in (7.62 cm)             | 5 in (12.7 cm)             | 4.25 in (10.795 cm)           |
| 9552-610F   | 3 in (7.62 cm)             | 5 in (12.7 cm)             | 4.25 in (10.795 cm)           |
| 9553-610F   | 3 in (7.62 cm)             | 5 in (12.7 cm)             | 4.25 in (10.795 cm)           |
| 9561-110F   | 4.5 in (11.43 cm)          | 7.75 in (19.685 cm)        | 4.25 in (10.795 cm)           |
| 9561-810F   | 4.5 in (11.43 cm)          | 5 in (12.7 cm)             | 4.25 in (10.795 cm)           |
| 9562-810F   | 4.5 in (11.43 cm)          | 5 in (12.7 cm)             | 4.25 in (10.795 cm)           |
| 9563-810F   | 4.5 in (11.43 cm)          | 5 in (12.7 cm)             | 4.25 in (10.795 cm)           |
| 9563-910F   | 4.5 in (11.43 cm)          | 5 in (12.7 cm)             | 4.25 in (10.795 cm)           |
| 9565-710F   | 4.5 in (11.43 cm)          | 10 in (25.4 cm)            | 4.25 in (10.795 cm)           |
| 9565-810F   | 4.5 in (11.43 cm)          | 10 in (25.4 cm)            | 4.25 in (10.795 cm)           |
| 9566-710F   | 4.5 in (11.43 cm)          | 10 in (25.4 cm)            | 4.25 in (10.795 cm)           |
| 9566-810F   | 4.5 in (11.43 cm)          | 10 in (25.4 cm)            | 4.25 in (10.795 cm)           |
| 9570-610F   | 4.42 in (11.23 cm)         | 9.88 in (25.08 cm)         | 4.25 in (10.795 cm)           |
| 9571-610F   | 4.42 in (11.23 cm)         | 9.88 in (25.08 cm)         | 4.25 in (10.795 cm)           |
| 9572-610F   | 4.42 in (11.23 cm)         | 5.02 in (12.75 cm)         | 4.25 in (10.795 cm)           |
| 9651-110F   | 3 in (7.62 cm)             | 5 in (12.7 cm)             | 4.25 in (10.795 cm)           |
| 9652-610F   | 3 in (7.62 cm)             | 5 in (12.7 cm)             | 4.25 in (10.795 cm)           |
| 9653-610F   | 3 in (7.62 cm)             | 5 in (12.7 cm)             | 4.25 in (10.795 cm)           |
| 9661-110F   | 4.5 in (11.43 cm)          | 7.75 in (19.685 cm)        | 4.25 in (10.795 cm)           |
| 9661-510F   | 4.5 in (11.43 cm)          | 5 in (12.7 cm)             | 4.25 in (10.795 cm)           |
| 9661-610F   | 4.5 in (11.43 cm)          | 5 in (12.7 cm)             | 4.25 in (10.795 cm)           |
| 9661-710F   | 4.5 in (11.43 cm)          | 5 in (12.7 cm)             | 4.25 in (10.795 cm)           |
| 9661-810F   | 4.5 in (11.43 cm)          | 5 in (12.7 cm)             | 4.25 in (10.795 cm)           |
| 9661-910F   | 4.5 in (11.43 cm)          | 5 in (12.7 cm)             | 4.25 in (10.795 cm)           |
| 9662-110F   | 4.5 in (11.43 cm)          | 7.75 in (19.685 cm)        | 4.25 in (10.795 cm)           |
| 9662-610F   | 4.5 in (11.43 cm)          | 5 in (12.7 cm)             | 4.25 in (10.795 cm)           |
| 9662-710F   | 4.5 in (11.43 cm)          | 5 in (12.7 cm)             | 4.25 in (10.795 cm)           |
| 9662-810F   | 4.5 in (11.43 cm)          | 5 in (12.7 cm)             | 4.25 in (10.795 cm)           |
| 9662-910F   | 4.5 in (11.43 cm)          | 5 in (12.7 cm)             | 4.25 in (10.795 cm)           |
| 9663-610F   | 4.5 in (11.43 cm)          | 5 in (12.7 cm)             | 4.25 in (10.795 cm)           |
| 9664-110F   | 4.5 in (11.43 cm)          | 7.75 in (19.685 cm)        | 4.25 in (10.795 cm)           |
| 9664-810F   | 4.5 in (11.43 cm)          | 5 in (12.7 cm)             | 4.25 in (10.795 cm)           |
| 9667-110F   | 4.5 in (11.43 cm)          | 7.75 in (19.685 cm)        | 4.25 in (10.795 cm)           |
| 9667-810F   | 4.5 in (11.43 cm)          | 5 in (12.7 cm)             | 4.25 in (10.795 cm)           |
| 9667-910F   | 4.5 in (11.43 cm)          | 5 in (12.7 cm)             | 4.25 in (10.795 cm)           |
| 9668-110F   | 4.5 in (11.43 cm)          | 7.75 in (19.685 cm)        | 4.25 in (10.795 cm)           |
| 9670-110F   | 7 in (17.78 cm)            | 19 in (48.26 cm)           | 4.75 in (12.065 cm)           |

| Panel Model | Width<br>(across DIN rail) | Length<br>(along DIN rail) | Height<br>(out from DIN rail) |
|-------------|----------------------------|----------------------------|-------------------------------|
| 9670-610F   | 7 in (17.78 cm)            | 19 in (48.26 cm)           | 4.75 in (12.065 cm)           |
| 9671-610F   | 4.42 in (11.23 cm)         | 5.02 in (12.75 cm)         | 4.25 in (10.795 cm)           |
| 9671-810F   | 7 in (17.78 cm)            | 19 in (48.26 cm)           | 4.75 in (12.065 cm)           |
| 9672-810F   | 7 in (17.78 cm)            | 19 in (48.26 cm)           | 4.75 in (12.065 cm)           |
| 9673-810F   | 7 in (17.78 cm)            | 19 in (48.26 cm)           | 4.75 in (12.065 cm)           |
| 9750-210F   | 3 in (7.62 cm)             | 5 in (12.7 cm)             | 4.25 in (10.795 cm)           |
| 9750-310F   | 3 in (7.62 cm)             | 5 in (12.7 cm)             | 4.25 in (10.795 cm)           |
| 9750-410F   | 3 in (7.62 cm)             | 5 in (12.7 cm)             | 4.25 in (10.795 cm)           |
| 9750-810F   | 3 in (7.62 cm)             | 5 in (12.7 cm)             | 4.25 in (10.795 cm)           |
| 9753-110F   | 3 in (7.62 cm)             | 5 in (12.7 cm)             | 4.25 in (10.795 cm)           |
| 9760-210F   | 4.5 in (11.43 cm)          | 10 in (25.4 cm)            | 4.25 in (10.795 cm)           |
| 9760-410F   | 4.5 in (11.43 cm)          | 10 in (25.4 cm)            | 4.25 in (10.795 cm)           |
| 9761-210F   | 4.5 in (11.43 cm)          | 5 in (12.7 cm)             | 4.25 in (10.795 cm)           |
| 9761-410F   | 4.5 in (11.43 cm)          | 5 in (12.7 cm)             | 4.25 in (10.795 cm)           |
| 9762-210F   | 4.5 in (11.43 cm)          | 5 in (12.7 cm)             | 4.25 in (10.795 cm)           |
| 9762-410F   | 4.5 in (11.43 cm)          | 5 in (12.7 cm)             | 4.25 in (10.795 cm)           |
| 9763-810F   | 4.5 in (11.43 cm)          | 5 in (12.7 cm)             | 4.25 in (10.795 cm)           |
| 9764-310F   | 3.5 in (8.89 cm)           | 19 in (48.26 cm)           | 3 in (7.62 cm)                |
| 9765-210F   | 4.5 in (11.43 cm)          | 10 in (25.4 cm)            | 4.25 in (10.795 cm)           |
| 9765-610F   | 4.5 in (11.43 cm)          | 5 in (12.7 cm)             | 4.25 in (10.795 cm)           |
| 9766-210F   | 4.5 in (11.43 cm)          | 5 in (12.7 cm)             | 4.25 in (10.795 cm)           |
| 9766-510F   | 4.5 in (11.43 cm)          | 5 in (12.7 cm)             | 4.25 in (10.795 cm)           |
| 9771-210F   | 4.5 in (11.43 cm)          | 5.729 in (14.552 cm)       | 4.25 in (10.795 cm)           |
| 9782-110F   | 4.42 in (11.23 cm)         | 5.02 in (12.75 cm)         | 4.25 in (10.795 cm)           |
| 9783-110F   | 4.42 in (11.23 cm)         | 5.02 in (12.75 cm)         | 4.25 in (10.795 cm)           |
| 9784-610F   | 4.42 in (11.23 cm)         | 5.02 in (12.75 cm)         | 4.25 in (10.795 cm)           |
| 9785-610F   | 4.42 in (11.23 cm)         | 5.02 in (12.75 cm)         | 4.25 in (10.795 cm)           |
| 9786-110F   | 4.42 in (11.23 cm)         | 5.02 in (12.75 cm)         | 4.25 in (10.795 cm)           |
| 9787-110F   | 4.42 in (11.23 cm)         | 5.02 in (12.75 cm)         | 4.25 in (10.795 cm)           |
| 9789-610F   | 4.42 in (11.23 cm)         | 9.88 in (25.08 cm)         | 4.25 in (10.795 cm)           |
| 9790-610F   | 4.42 in (11.23 cm)         | 5.02 in (12.75 cm)         | 4.25 in (10.795 cm)           |
| 9791-610F   | 4.42 in (11.23 cm)         | 5.02 in (12.75 cm)         | 4.25 in (10.795 cm)           |
| 9792-610F   | 4.42 in (11.23 cm)         | 7.75 in (19.685 cm)        | 4.25 in (10.795 cm)           |
| 9793-110F   | 4.42 in (11.23 cm)         | 5.02 in (12.75 cm)         | 4.25 in (10.795 cm)           |
| 9794-110F   | 4.42 in (11.23 cm)         | 5.02 in (12.75 cm)         | 4.25 in (10.795 cm)           |
| 9795-610F   | 4.42 in (11.23 cm)         | 5.02 in (12.75 cm)         | 4.25 in (10.795 cm)           |
| 9853-610F   | 3 in (7.62 cm)             | 5 in (12.7 cm)             | 4.25 in (10.795 cm)           |
| 9860-610F   | 4.42 in (11.23 cm)         | 5.02 in (12.75 cm)         | 4.25 in (10.795 cm)           |
| 9861-610F   | 4.42 in (11.23 cm)         | 5.02 in (12.75 cm)         | 4.25 in (10.795 cm)           |
| 9863-710F   | 3 in (7.62 cm)             | 6.66 in (16.9164 cm)       | 4.25 in (10.795 cm)           |
| 9871-810F   | 3 in (7.62 cm)             | 5 in (12.7 cm)             | 4.25 in (10.795 cm)           |

# Field Termination Options

| Panel Model | Width (across DIN rail) | Length (along DIN rail) | Height (out from DIN rail) |
|-------------|-------------------------|-------------------------|----------------------------|
| 9881-810F   | 3 in (7.62 cm)          | 5 in (12.7 cm)          | 4.25 in (10.795 cm)        |
| BP9228-010F | 3.5 in (8.89 cm)        | 19 in (48.26 cm)        | 8 in (20.32 cm)            |
| BP9229-010F | 3.5 in (8.89 cm)        | 19 in (48.26 cm)        | 8 in (20.32 cm)            |

## Sample Drawings of External Termination Panels

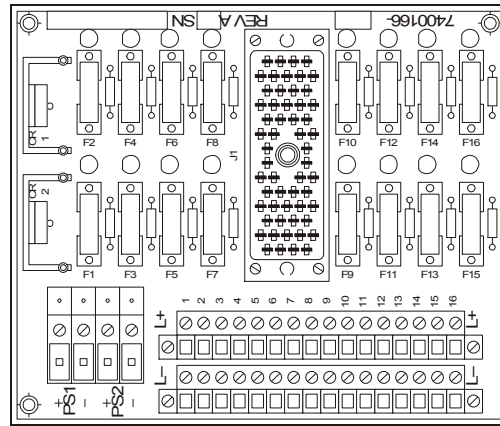
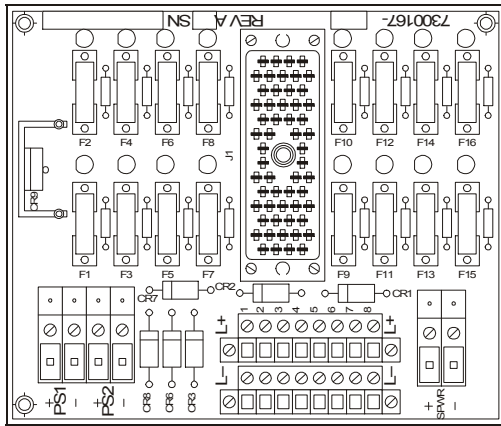

8-Point and 16-Point Digital Output Termination Panels with Fuses

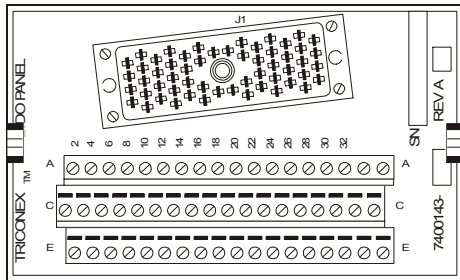

Basic Termination Panel for Various Types of I/O Modules

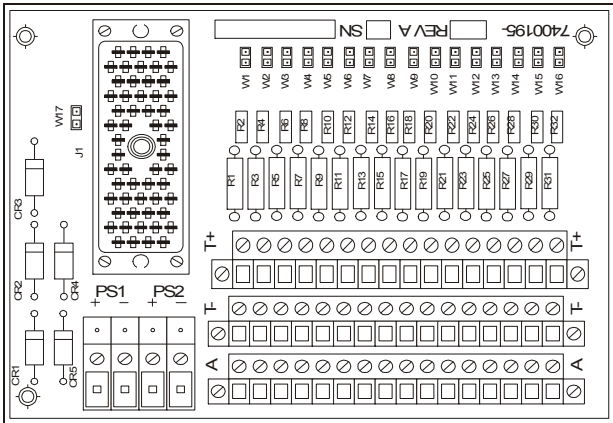

16-Point Analog Input and Digital Input Termination Panels

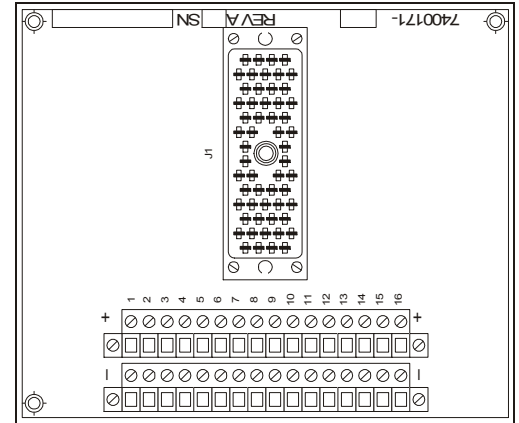

16-Point Thermocouple Input and Analog Input Termination Panels

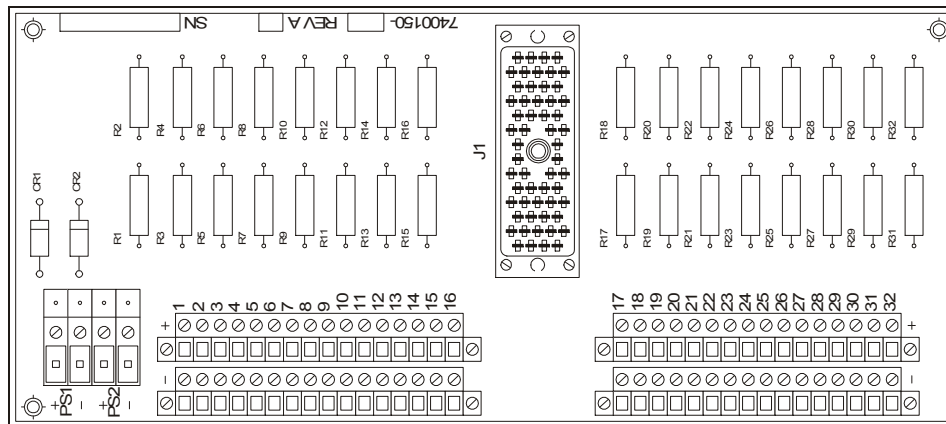

32-Point Analog Input and Digital Input Termination Panels

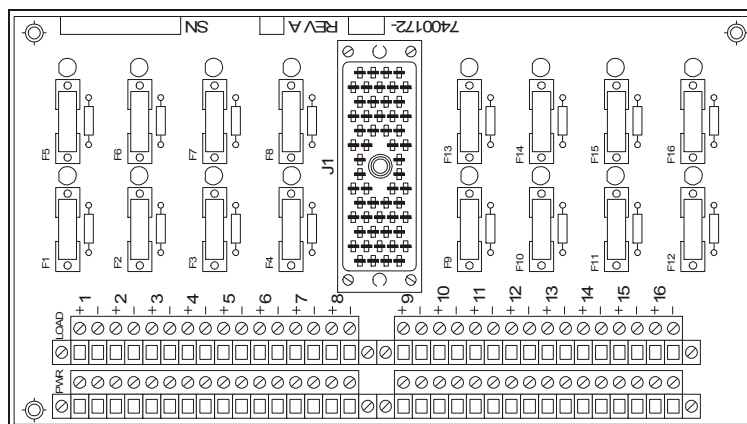

Standard Non-Commoned Termination Panels for Digital Input, Digital Output and Relay Modules

# Field Termination Options

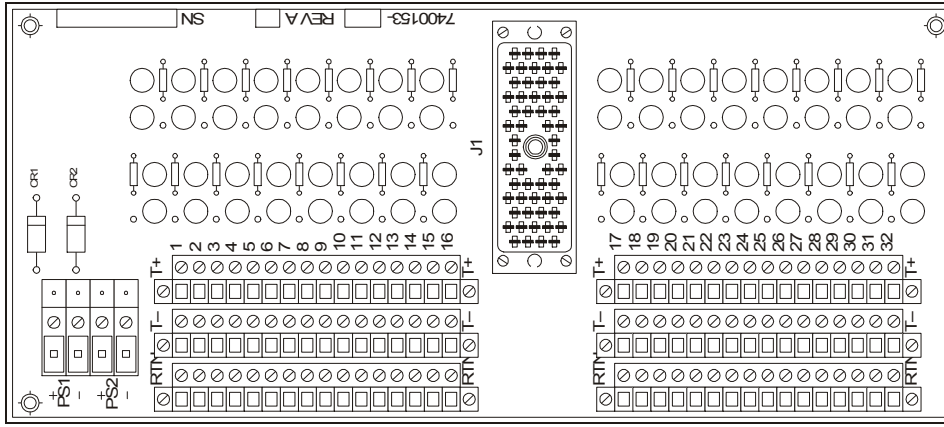

3-Wire Transmitter Analog Input Termination Panel

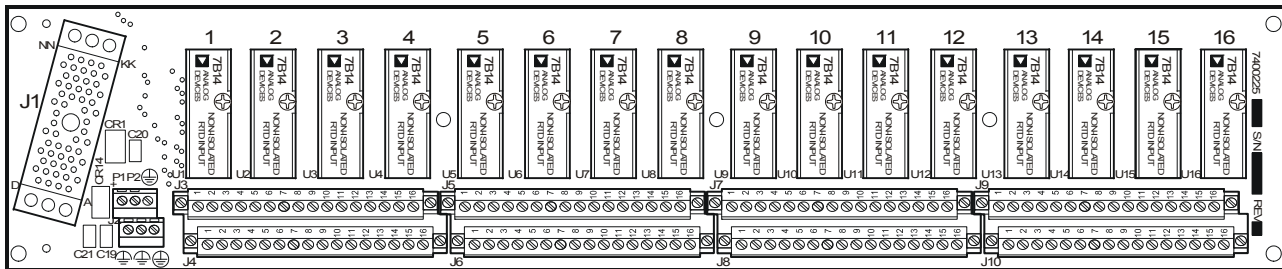

RTD/TC/AI External Termination Panel

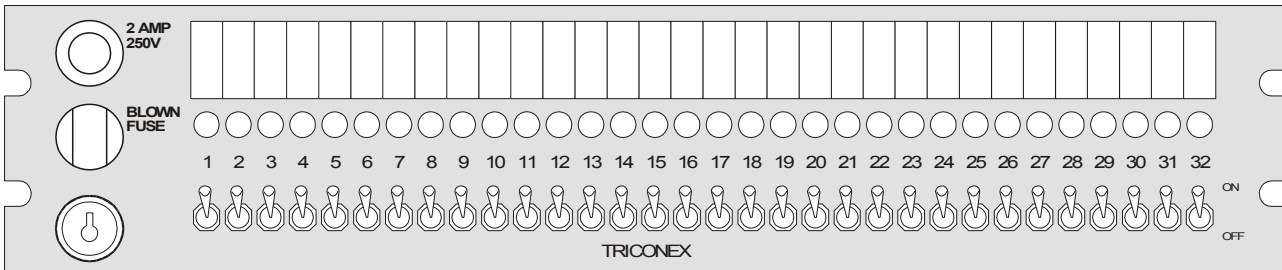

External Bypass Termination Panel

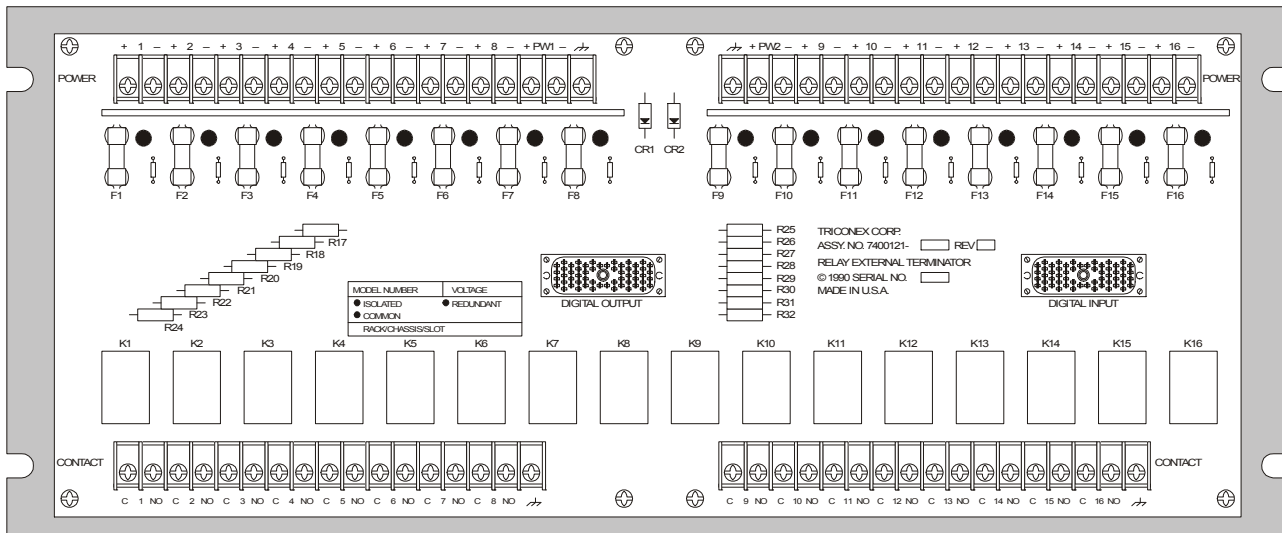

External Relay Termination with 16 Interposing Relay Contacts

## Sample Drawings of Nonincendive External Termination Panels

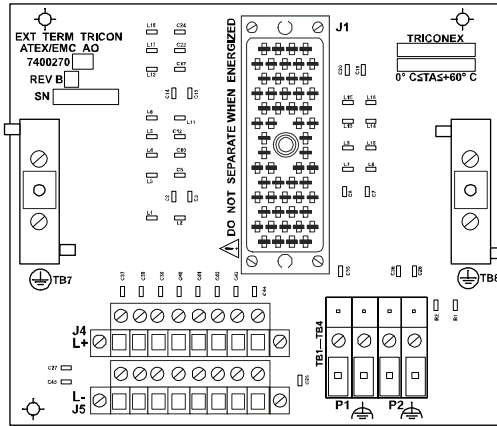

8-Point Nonincendive Analog Output Termination Panels

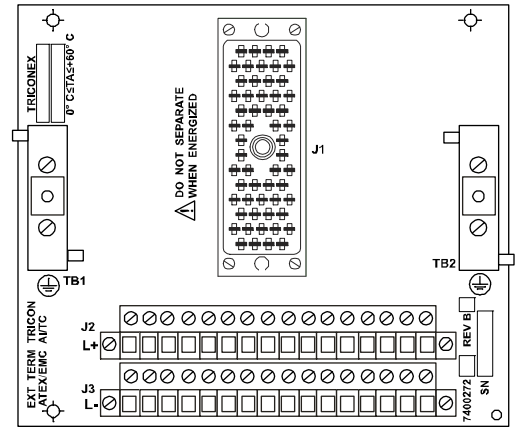

16-Point Nonincendive Analog Input and Pulse Input Termination Panels

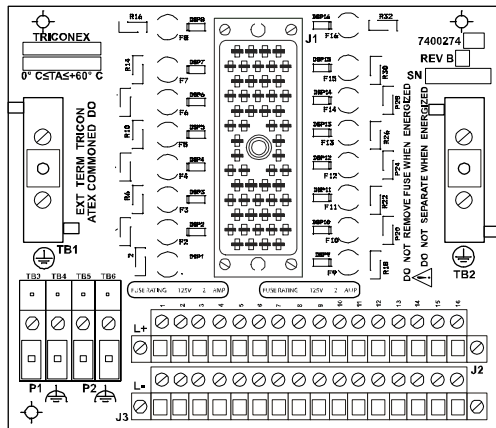

16-Point Nonincendive Digital Output Termination Panels

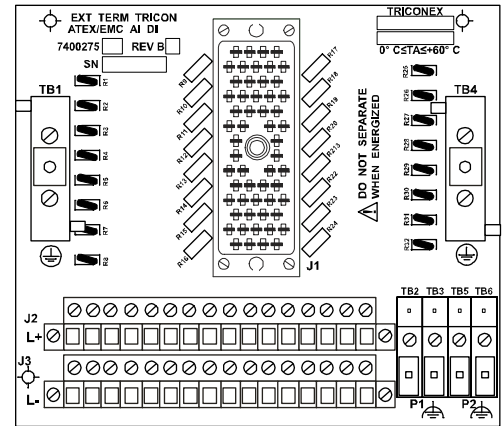

16-Point Nonincendive Current Analog Input and Digital Input Termination Panels

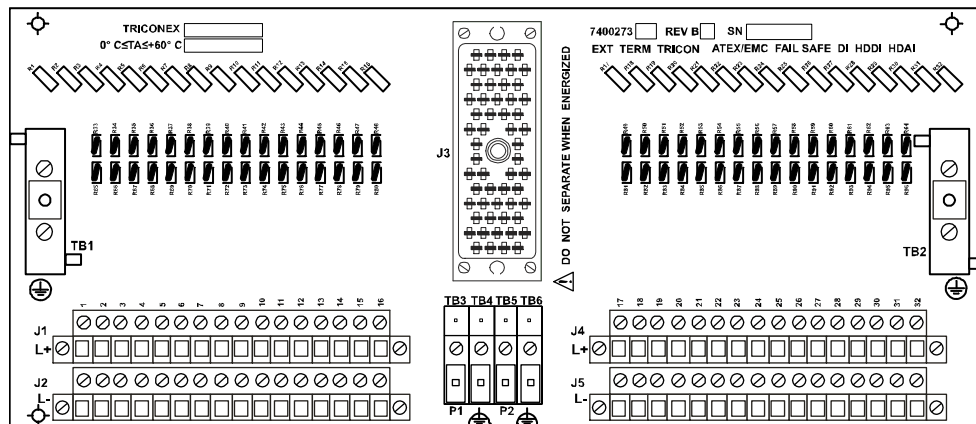

32-Point Nonincendive Analog Input and Digital Input Termination Panels



*The Tricon controller can interface with Modbus masters and slaves, Distributed Control Systems (DCS), external host computers on Ethernet networks, other Triconex Controllers on a Peer-to-Peer network, and a TriStation 1131 PC.*

## Communication Capabilities

In most process-control applications, there are two systems which monitor and manage the process. One is a Distributed Control System (DCS) and the other is a safety system such as the Tricon controller. These two systems are usually isolated, but share a common operator interface. Distributed Control Systems are designed to allow highly effective communication with the process operator, who must be informed of the state of the process at all times. This is desirable for safety systems as well, but was not feasible in the past because of the type of technology used to implement these systems.

Today, the state-of-the-art, microprocessor-based architecture of the Tricon controller supports several modes of communication. Depending on control program requirements, the Tricon can interface with:

- Any Modbus master, including DCS from ABB, Bailey, Fisher-Rosemount and Yokogawa
- Modbus slave devices
- A Foxboro Intelligent Automation (I/A) Series Nodebus
- A Honeywell Universal Control Network (UCN)
- A Honeywell Data Hiway and Local Control Network (LCN)

- External host computers on Ethernet (802.3) networks
- Other Triconex controllers in a Peer-to-Peer, TÜV-certified network
- A TriStation 1131 PC
- OPC Server for Triconex

### Networking with Modbus

The *Tricon Communication Module (TCM)* supports the industry-standard Modbus protocol over a serial link or a TCP network. The *Enhanced Intelligent Communication Module (EICM)* supports the Modbus protocol over a serial link. Most suppliers of operator

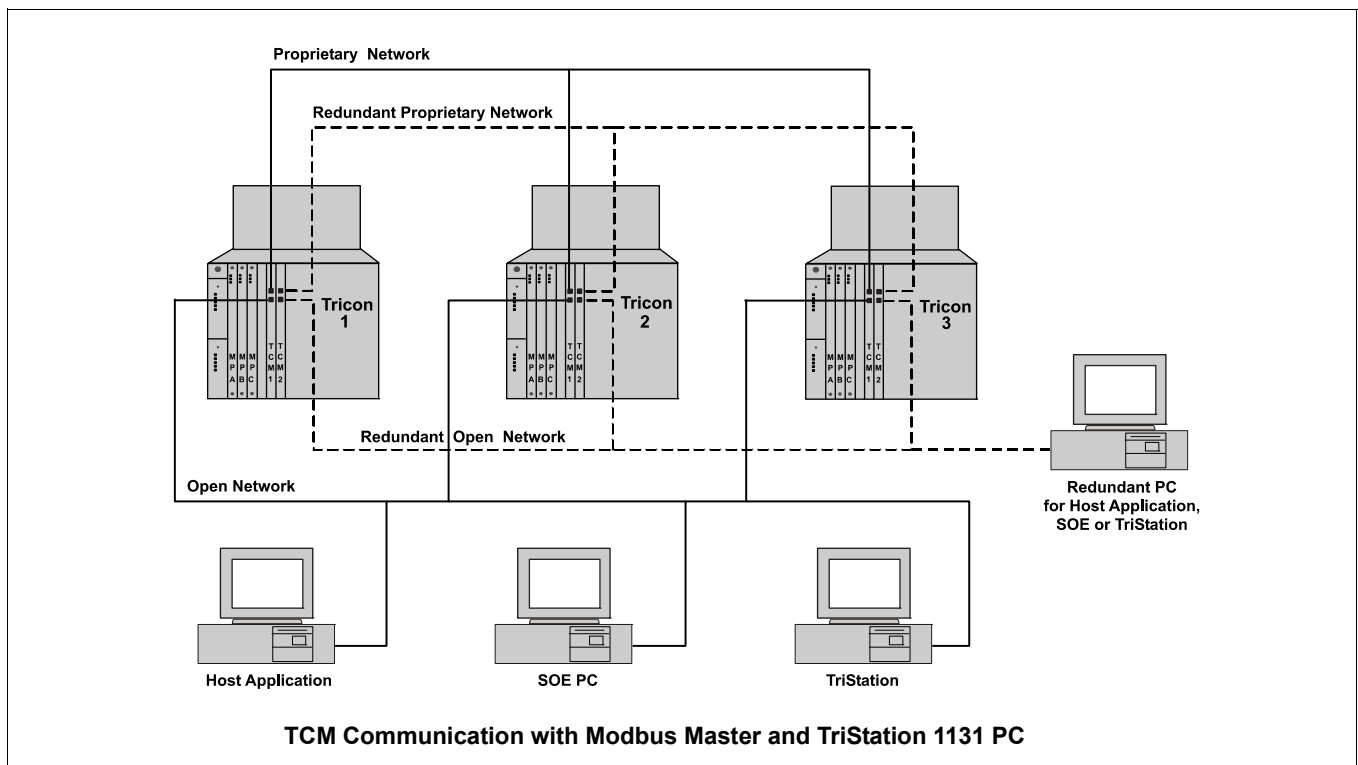

# Communication Capabilities

workstation software (PC-based or mini-computer-based) support Modbus RTU and ASCII protocol, as do most DCS vendors, by means of a network-bridging device.

Because the TCM and the EICM can operate as a Modbus master or slave (the EICM can simultaneously act as both), the productivity of the Tricon controller can be expanded in a low-cost manner for non-critical I/O. When the TCM or the EICM operates as the master, it can control slave devices such as annunciators, bypass switches on non-critical PLCs, or other Tricon controllers. When the TCM or the EICM operates as a slave, a computer on the network is the master—this can be a DCS, an operator workstation, or any general-purpose computer programmed to support Modbus devices.

TCM and EICM users can select the RS-232 point-to-point interface for one master and one slave, or the RS-485 interface for one master and up to 32 slaves. The RS-485 network trunk can be one or two twisted-pair wires up to a maximum of 4,000 feet (1,200 meters).

While the TCM and the EICM are appropriate for many applications, Invensys offers alternate communication methods when fast response time or a large amount of data throughput is required.

## Networking with Ethernet

The Tricon controller supports Ethernet (802.3) communication through the NET 1 and NET 2 ports on the Tricon Communication Module (TCM), and the NET 2 ports on the Advanced Communication Module (ACM) and the Network Communication Module (NCM). All of these modules support Triconex applications, user-written applications, and “open” networking

| Protocols                                      | TCM | EICM | NCM | ACM |
|--|-----|------|-----|-----|
| Peer-to-Peer                                   | ✓   | —    | ✓   | —   |
| Time Synchronization                           | ✓   | —    | ✓   | —   |
| Trimble GPS (TAIP)                             | ✓   | —    | —   | —   |
| SNTP   | ✓   | —    | —   | —   |
| Network Printing using Jet Direct              | ✓   | ✓    | —   | —   |
| TriStation                                     | ✓   | ✓    | ✓   | ✓   |
| Tricon System Access control program (TSAA)    | ✓   | —    | ✓   | ✓   |
| <b>Protocols for User-Written Applications</b> |     |      |     |     |
| Modbus RTU and ASCII                           | ✓   | ✓    | —   | —   |
| Modbus TCP                                     | ✓   | —    | —   | —   |
| TCP-IP/TCP-UDP                                 | ✓   | —    | ✓   | ✓   |
| <b>Triconex Applications</b>                   |     |      |     |     |
| Sequence of Events                             | ✓   | —    | ✓   | ✓   |
| DDE Server                                     | ✓   | —    | ✓   | ✓   |
| TriStation 1131                                | ✓   | ✓    | ✓   | ✓   |
| Enhanced Diagnostic Monitor                    | ✓   | —    | —   | —   |
| OPC Server for Triconex <sup>a</sup>           | ✓   | —    | ✓   | —   |

### Protocols and Applications for Networking

#### NOTES

<sup>a</sup>TCM Models 4351A, 4351B, 4352A, and 4352B, and NCMs rely on an external Matrikon OPC Server. TCM Models 4353 and 4354 have an Embedded OPC Server.

See page 33, page 35, page 37, and page 38 for network port usage on the TCM, EICM, NCM, and ACM

with external systems by means of TCP-IP/UDP-IP protocol.

In addition, the TCM and NCM support the Triconex Peer-to-Peer and Time Synchronization protocols on the NET 1 port. The TCM and NCM also support a fully redundant OPC capability. The table above lists the protocols and applications that can be used with the TCM, NCM, and ACM.

To maximize safety, the Tricon system offers module, media, and workstation redundancy. Module/media redundancy is achieved by installing two TCMs, NCMs, or ACMs in the same logical slot and connecting their network nodes with two sets of cables. This arrangement permits continuous operation in case of broken cables,

intermittent cable connections, port failures, or TCM/ NCM/ACM failures.

External host redundancy is obtained by connecting a spare external host machine to the network. If the primary host fails, it can be shut down and the control program restarted on the spare host. All Triconex applications use PCs as external hosts, so all of the applications could be loaded on the primary and spare hosts without requiring any other PCs.

#### Triconex Protocols

A protocol is a set of rules for exchanging data between two or more devices. In a Peer-to-Peer protocol, any device on the network can initiate a data transfer operation. In a master/slave protocol, only the master can initiate a

data exchange. Invensys has developed one peer-to-peer protocol and three master/slave protocols (Time Synchronization, TriStation, and TSAA) to support different types of applications. All of the following Triconex protocols support a maximum of 31 Tricon controllers on a network. Please contact Invensys for application guidelines and potential performance limitations.

**Peer-to-Peer**

Peer-to-Peer protocol allows Tricon controllers to exchange small amounts of safety and process information on the proprietary network. For information about using the Peer-to-Peer Send and Recv functions in applications, see the *TriStation 1131 Developer's Guide*.

**Time Synchronization**

Time Synchronization is a master/slave protocol used to maintain a consistent time base for all Tricon controllers connected to each other by means of TCMs or NCMs.

**TriStation**

The TriStation protocol is a master/slave protocol in which the master (the TriStation 1131 PC) communicates with the slave (the Tricon controller) over an Ethernet network. Although the TriStation protocol supports a maximum of 31 Tricon controllers, the master can

communicate with only one slave at a time.

**TSAA**

The Tricon System Access control program (TSAA) protocol is a master/slave protocol in which the master (the external host) communicates with one or more slaves (Tricon controllers) over an open network. TSAA specifies the interfaces, commands and data structures used to develop applications that send and receive data to and from Tricon controllers.

TSAA can be used to develop these types of applications:

- Control (read/write) applications such as an operator interface that requires access to Tricon controller status and the ability to write data to the Tricon controller.
- Monitor (read only) applications such as a Sequential Events Recorder, Event Logger or status display that retrieves data from the Tricon controller.

For more information about TSAA, see the *Communication Guide for Tricon v9-v10 Systems*.

**Triconex Applications**

Invensys offers several applications for Ethernet (802.3) networks, all of which use a PC as the external host. These

applications are briefly described in the table below.

The Tricon controller offers considerable flexibility and functionality in the area of data communication, and can readily be configured to match control program requirements. Invensys is continually striving to advance the state of the art in safety systems. High-speed, redundant network communication is another example of that commitment.

**Foxboro's Intelligent Automation Series System**

Invensys offers the *Advanced Communication Module (ACM)* for tightly-integrated interfacing with Foxboro's Intelligent Automation (I/A) Series Nodebus. The ACM communicates process information at full network data rates for use anywhere on the I/A Series system, transmitting all Tricon aliased data and diagnostic information to operator workstations in display formats that are familiar to Foxboro operators.

The ACM makes the following functions available to the I/A Series:

- Handles critical I/O points and passes results to the I/A Series
- Processes Tricon controller alarms and propagates them to user-defined

| Triconex Application                 | Description  |
|--------------------------------------|--|
| TriStation 1131                      | Allows development, testing, and monitoring of applications for the Tricon controller.   |
| Sequence of Events (SOE)             | Retrieves events (state changes of discrete variables) from Tricon controllers on a network. For system maintenance and shutdown analysis.   |
| Enhanced Diagnostic Monitor          | Allows monitoring the hardware and application status of Tricon controllers.   |
| DDE Server                           | Allows Windows-based DDE client applications such as Microsoft® Excel® to read and write Tricon aliased data.  |
| OPC Server for Triconex <sup>a</sup> | Allows OPC clients to have read and write access to Triconex controller program variables. Requires the Network Communication Module (NCM) or the Tricon Communication Module (TCM). |

<sup>a</sup>TCM Models 4351A, 4351B, 4352A, and 4352B, and NCMs rely on an external Matrikon OPC Server. TCM Models 4353 and 4354 have an embedded OPC Server.

## Communication Capabilities

---

I/A Series destinations (consoles, printers, etc.)

- Propagates Tricon controller alarms as I/A Series system messages
- Reads/writes aliased data to satisfy I/A Series requests
- Enables time synchronization from the I/A Series environment
- Reads Tricon controller diagnostics for display by the I/A Series workstation
- Provides write protection to lock out changes to the Tricon controller from all I/A Series sources
- Provides hot-spare capability for uninterrupted communication with the I/A Series Nodebus

The ACM also supports these Triconex protocols and applications on external host PCs connected to a separate BNC port (that is, NET 2):

- TriStation protocol for the TriStation 1131 software
- TSAA protocol for Triconex applications
- TSAA/TCP(UDP)/IP for user-written applications on external hosts

### Honeywell's TDC-3000 DCS

Invensys offers the *Safety Manager Module (SMM)* and the *Hiway Interface Module (HIM)* for tightly-integrated interfacing with various networks of the TDC-3000 DCS.

The SMM is used solely for communication with the Universal Control Network (UCN), one of three principal networks of the TDC-3000. Appearing to the Honeywell system as a safety node, the SMM communicates process information at full network data rates for use anywhere on the TDC-3000. The SMM transmits all Tricon aliased data and diagnostic information to operator workstations in display formats that are familiar to Honeywell operators.

The SMM makes the following functions available to the TDC-3000:

- Handles critical I/O points and passes results to the DCS
- Processes Tricon controller alarms and propagates them to user-defined DCS destinations (consoles, printers, etc.)
- Reads/writes aliased data to satisfy DCS requests
- Reads Tricon controller diagnostics for display by the DCS
- Provides write protection to lock out changes to the Tricon controllers from all TDC-3000 sources
- Enables time synchronization from the DCS
- Allows Peer-to-Peer communication for plants with many Tricon controllers
- Provides sequence of events to help determine the cause of plant trips and increase process uptime
- Provides hot-spare capability for uninterrupted communication with Honeywell networks

The HIM interfaces with the TDC-3000 by means of the Hiway Gateway and Local Control Network (LCN). The HIM can also interface with Honeywell's older TDC 2000 control system by means of the Data Hiway. Using the HIM, higher-order devices on the LCN or Data Hiway (such as computers and operator workstations) can communicate with the Tricon controller.

Both the SMM and the HIM offer the hot-spare capability for uninterrupted communication with Honeywell networks.

*Easy-to-use developer's workbench allows you to develop, test, and document process-control applications for the Tricon controller.*

## TriStation 1131 Developer's Workbench

TriStation 1131 Developer's Workbench is an integrated tool for developing, testing, and documenting safety and critical-process control applications for the Tricon controller. The programming methodology, user interface and self-documentation capabilities make the system superior to traditional and competing engineering tools.

This table identifies the compatibility of Tricon system and TriStation 1131 software versions.

| TriStation 1131 | Tricon        |
|-----------------|---------------|
| 4.1.419–4.1.420 | 10.0.x        |
| 4.1.433         | 10.0.x–10.1.x |
| 4.1.437         | 10.0.x–10.2.x |
| 4.2.x           | 10.0.x–10.3.x |
| 4.3.x–4.5.x     | 10.0.x–10.4.x |
| 4.6.x–4.10.x    | 10.0.x–10.5.x |

The TriStation 1131 software is compliant with Part 3 of the IEC 61131 International Standard for Programmable Controllers, which defines programming languages.

The TriStation 1131 v4.7.0 and later software supports the following Windows operating systems:

- Windows® XP Professional
- Windows 7 Professional/Enterprise (32-bit and 64-bit)
- Windows Server® 2003
- Windows Server 2008 R2 (32-bit and 64-bit)

For detailed version compatibility information, see the *Product Release*

*Notice for TriStation 1131 v4.x, available on the Invensys Global Customer Support (GCS) website.*

### Functional Overview

The TriStation 1131 software provides three editors which support these IEC 61131-3 languages:

- Function Block Diagram
- Ladder Diagram
- Structured Text

An optional Triconex programming language, CEMPLE (Cause and Effect Matrix Programming Language Editor) supports the widely used Cause and Effect Matrix (CEM) methodology.

The TriStation 1131 software allows you to:

- Create programs, functions, and function blocks
- Define the controller configuration

- Declare tagnames
- Test applications in the Triconex Emulator
- Download and monitor applications

### Features in TriStation 1131 v4.10.0

TriStation 1131 version 4.10.0 is a significant release, with the following new features:

- I/O Utilization and Disabled Points Reports
- Support for process alarm configuration and monitoring
- Verification of downloaded programs
- Enhanced Peer-to-Peer communication

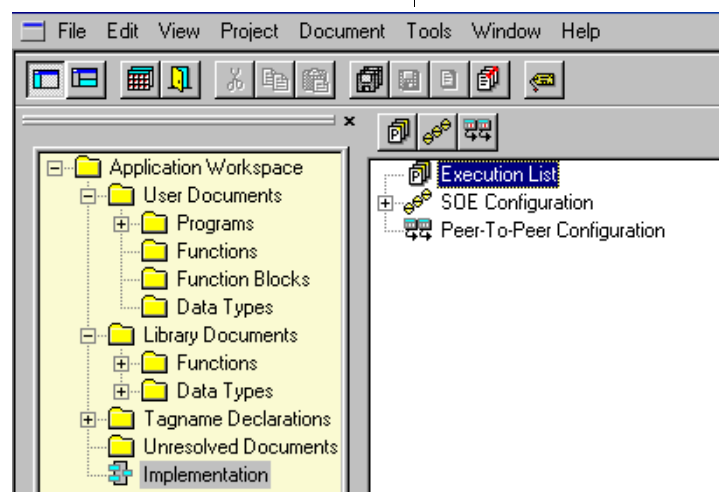

Example of the TriStation 1131 4.x Software Interface

# TriStation 1131 Developer's Workbench

## Enhanced Diagnostic Monitor

The Enhanced Diagnostic Monitor is an application which monitors the hardware health of Triconex controllers and allows users to effectively troubleshoot the safety system during maintenance.

Starting with TriStation 1131 v4.1.437, the Enhanced Diagnostic Monitor is a separate application from the TriStation 1131 software.

For more information on the Enhanced Diagnostic Monitor, see the online Help or printed guide included with the Enhanced Diagnostic Monitor.

## Elements of a TriStation 1131 Project

A TriStation 1131 project contains all of the elements required to implement a safety or control program in a Tricon controller. Some of these elements are automatically included in every project by the TriStation 1131 software, while others are user-created.

### Programs

A program is the highest-level executable logic element in a TriStation 1131 project. It is an assembly of programming language elements (functions, function blocks, and data variables) that work together to allow a programmable control system to achieve control of a machine or a process. Each program is uniquely identified by a user-defined type name. A TriStation 1131 project can support hundreds of programs.

### Functions

A function is a logic element which yields exactly one result. Unlike a function block, the data associated with a function is not retained from one evaluation of the function to the next. Functions do not have to be instanced.

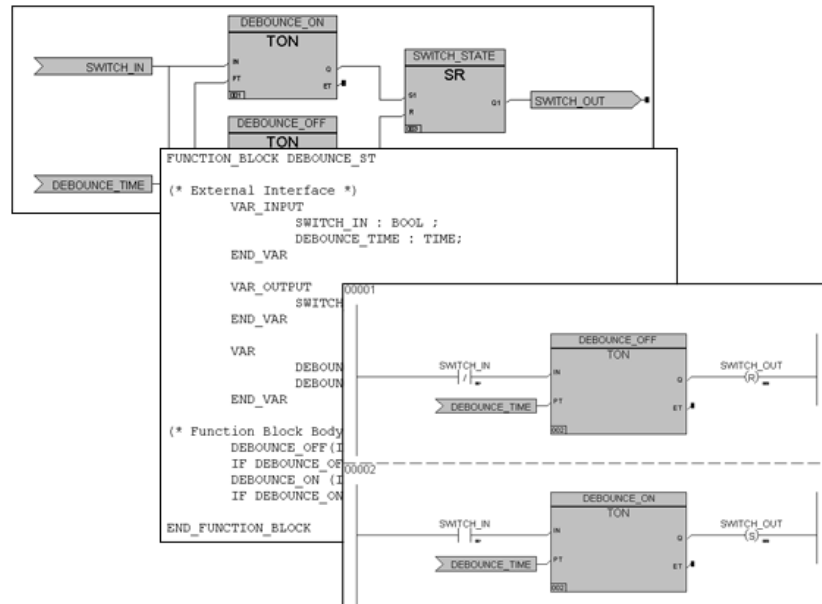

Sample Logic in FBD, ST, and LD Languages

### Function Blocks

A function block is a logic element which yields one or more results. To use a function block in a program, an instance of the function block type must first be declared. Each instance is identified by a user-defined instance name. All of the data associated with a specific instance of a function block is retained from one evaluation of the function block to the next.

### Data Types

A data type defines the size and characteristics of variables declared in a program, function or function block. Data types used by the TriStation 1131 software include discrete (BOOL), analog (DINT), and real (REAL).

### Libraries

The TriStation 1131 software includes libraries of pre-defined functions, function blocks, and data types that can be used in a project.

The TriStation 1131 software includes these libraries:

- IEC 61131-3 Standard Library – a set of functions and function blocks defined by the IEC 61131-3 Standard
- Triconex Library – a set of Triconex functions and function blocks that can be used with any Triconex programmable controller
- Tricon Library – a set of functions and function blocks that are specifically for use with the Tricon controller

In addition to the pre-defined libraries, you can also develop your own libraries of project elements. These libraries can include programs, functions, function blocks, and data types which can be imported to other TriStation 1131 projects.

### Programming Languages

The TriStation 1131 software includes these programming languages: Function Block Diagram, Structured Text, and Ladder Diagram. An optional language, CEMPLE, can be purchased separately.

### Function Block Diagram (FBD)

Function Block Diagram is a graphical language that corresponds to circuit diagrams. FBD elements appear as blocks that are wired together to form circuits. The wires transfer binary and other types of data between elements.

### Structured Text (ST)

Structure Text is a high-level, textual programming language that is similar to PASCAL. Structured Text allows Boolean and arithmetic expressions, and programming structures such as conditional (IF...THEN...ELSE) statements. Functions and function blocks can be invoked in Structured Text.

In the TriStation 1131 v4.0 software, these structures were added: arrays, structures, ForLoop and Exit statements, CASE statement, enumerated data types, var-external, and var-temp variables.

### Ladder Diagram (LD)

Ladder Diagram is a graphical language that uses a standard set of symbols for representing relay logic. The basic elements are coils and contacts which are connected by links. Links are different from the wires in

|  |            |                                    | OR                                    | OR                                    | OR                                    | OR                                    | OR                                    |                          |                          |
|--|------------|------------------------------------|---------------------------------------|---------------------------------------|---------------------------------------|---------------------------------------|---------------------------------------|--------------------------|--------------------------|
|  |            |                                    | UNIT_1_ALARM                          | UNIT_2_ALARM                          | UNIT_3_ALARM                          | UNIT_4_ALARM                          | UNIT_5_ALARM                          |                          |                          |
|  |            |                                    | Description                           | Description                           | Description                           | Description                           | Description                           |                          |                          |
|  |            |                                    | High level alarm indicator for tank 1 | High level alarm indicator for tank 2 | High level alarm indicator for tank 3 | High level alarm indicator for tank 4 | High level alarm indicator for tank 5 |                          |                          |
|  |            |                                    | Cause                                 | Description                           | E01                                   | E02                                   | E03                                   | E04                      | E05                      |
|  | LEVEL_1_   | TRUE=Fluid level in tank 1 is high | C01                                   | <input checked="" type="checkbox"/>   | <input type="checkbox"/>              | <input type="checkbox"/>              | <input type="checkbox"/>              | <input type="checkbox"/> | <input type="checkbox"/> |
|  | LEVEL_2_HI | TRUE=Fluid level in tank 2 is high | C02                                   | <input type="checkbox"/>              | <input checked="" type="checkbox"/>   | <input type="checkbox"/>              | <input type="checkbox"/>              | <input type="checkbox"/> | <input type="checkbox"/> |
|  | LEVEL_3_HI | TRUE=Fluid level in tank 3 is high | C03                                   | <input type="checkbox"/>              | <input type="checkbox"/>              | <input checked="" type="checkbox"/>   | <input type="checkbox"/>              | <input type="checkbox"/> | <input type="checkbox"/> |
|  | LEVEL_4_HI | TRUE=Fluid level in tank 4 is high | C04                                   | <input type="checkbox"/>              | <input type="checkbox"/>              | <input type="checkbox"/>              | <input checked="" type="checkbox"/>   | <input type="checkbox"/> | <input type="checkbox"/> |

| Loc | Terminal | Var/Const     | VarType | Data Type | Description |
|-----|----------|---------------|---------|-----------|-------------|
| C01 |          | P1_LEVEL_1_HI | Tagname | BOOL      |             |

Sample CEM from a TriStation 1131 Project

FBD in that they transfer only binary data between the elements.

### Cause and Effect Matrix Programming Language Editor (CEMPLE)

CEMPLE is a high-level graphical language that provides a two-dimensional matrix in which you can associate a problem in a process with one or more corrective actions. The problem is referred to as the cause and the action as the effect. The matrix associates a cause with an effect in the intersection of the cause row and the effect column.

CEMPLE is the first automated implementation of CEM, a methodology that is commonly used throughout the process-control industry and readily understood by a broad range of plant personnel. CEM diagrams are automatically translated into IEC 61131-3 compliant Function Block Diagrams, thereby eliminating the risks associated with manual translation from hand-drawn CEMs.

### Controller Configuration

In the TriStation 1131 software, the controller configuration identifies the modules in the system, communication settings, memory allocation for tagnames, and operating parameters. These configuration settings are included in the control program that is downloaded to the controller.

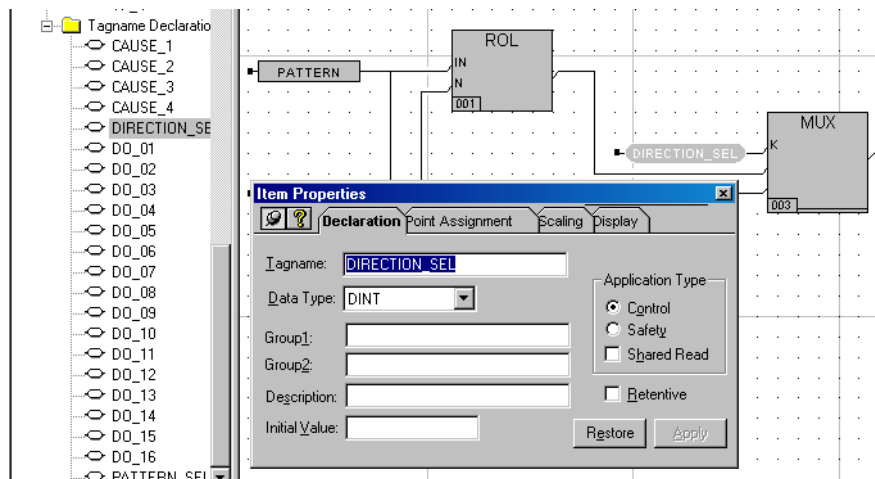

Declaring Tagnames in a Program

# TriStation 1131 Developer's Workbench

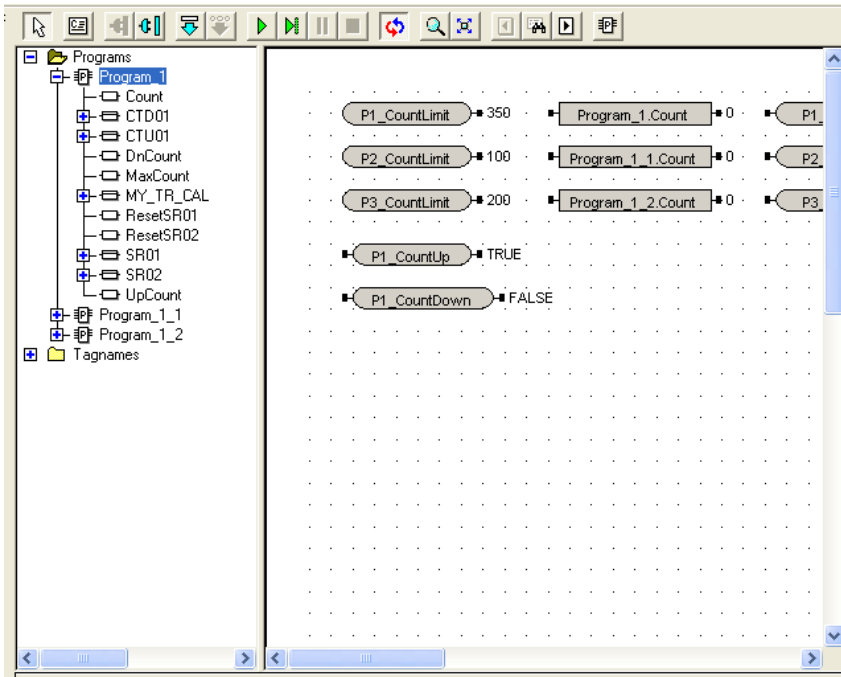

Emulator Panel

## Emulator Panel

The Emulator Panel allows you to connect to the Triconex Emulator, download the control program, and test and debug the control program. The panel lists the programs, variables, and tagnames in the control program. Testing can be done by dragging variables and tagnames from the list to the monitor panel and changing the values as desired. You can specify commands to run the control program without intervention, to run in single-step, or to halt the execution.

## Controller Panel

The Controller Panel allows connection to the controller for real-time execution of the control program.

## TriStation 1131 Interface Options

The TriStation 1131 software allows you to specify options to be used in the interface. For example, you can specify the drawing colors used in the programming editors, and editor options such as double-spacing between function block

terminals. You can also specify the directory location for files.

## Reports and Documentation

The TriStation 1131 software includes multiple methods of sorting data and documenting project elements, both during and after project development. Printouts of user-developed function blocks and programs can be obtained on a variety of user-selected engineering drawing templates.

Standard reports are available to document the project configuration data. You can also create customized reports with Crystal Reports™.

## Password Security

The TriStation 1131 software provides a security system that defines users and their privileges with regard to editing, library changes, state changes and other operations.

## Project History

An audit trail function is provided to document the history of a project and its

program version changes. This detailed log keeps track of user actions and comments by automatically time-stamping critical events within a session and manually logging user comments on demand.

## Annotations

Annotations can be added to constants, tagnames, and variables. An annotation can be used to display descriptive text, including information specified in system and user-modifiable macros. You can also display the value of a variable during program execution.

## Comments

Comments can be added to programs, functions, and function blocks to add information about the operations.

## Help Documentation

The TriStation 1131 software features an extensive online Help system which provides detailed information about TriStation 1131 features and functions.

*CEMPLE is the Triconex automated implementation of the traditional CEM methodology that has been used by process control engineers for decades.*

# CEM Programming Language Editor

Cause and Effect Matrix (CEM) is a methodology that is commonly used in the process control industry to define alarms, emergency shutdown strategies, and mitigation actions. For decades, process control engineers have used manual methods such as graph paper and spreadsheet programs to identify problem conditions and corrective actions.

## Automated CEM Called CEMPLE

The traditional CEM method is time-consuming and subject to errors caused by misinterpretation of the matrix or inaccurate coding. Triconex has automated the CEM process with the Cause and Effect Matrix Programming Language Editor, referred to as CEMPLE.

CEMPLE enables a cause and effect matrix to be used as the basis for a TriStation 1131 program.

## CEMPLE Features

CEMPLE includes the following features:

- Ability to specify up to 99 causes, 99 effects, and 1,000 intersections
- Ability to invoke functions and function blocks to evaluate cause, intersection, and effect states

- Automatic conversion of matrix to Function Block Diagram language
- Customized view monitoring of active causes, intersections, and effects
- Multiple levels of undo and redo editing

## CEM Editor

The CEM Editor includes the following components as shown in the figure below:

- Matrix
- FBD Network
- Variable Detail Table

## Matrix

As the major component of the CEM Editor, the Matrix identifies the parts of associated with causes, effects, and intersections. The Matrix can also include functions or function blocks related to causes, effects, and intersections.

## FBD Network

The FBD Network displays the Function Block Diagram (FBD) related to the cause, intersection, or effect that is selected in the matrix. It can also be used to specify properties and to invert values for variables.

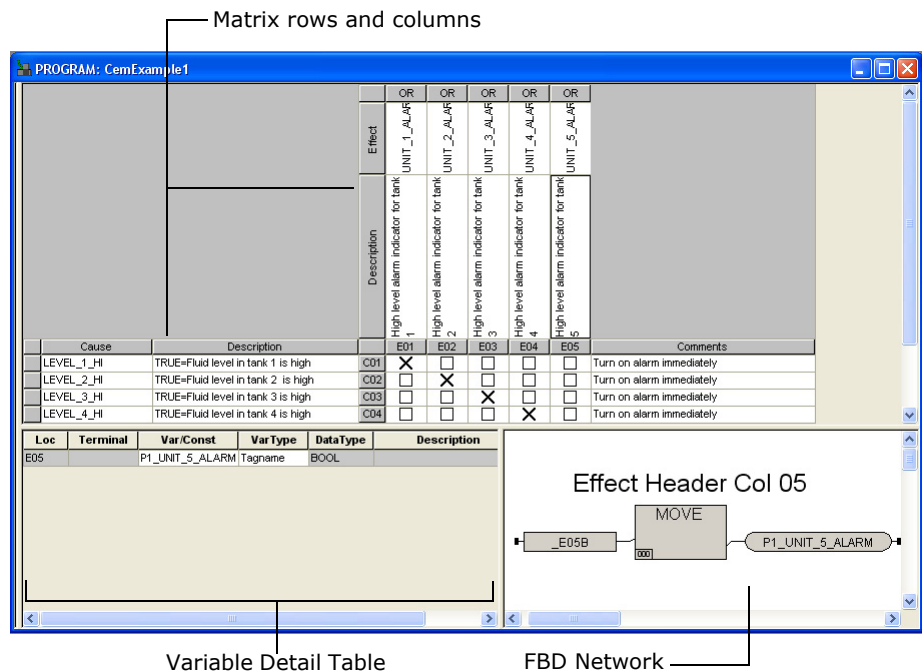

CEM Editor Components

# CEM Programming Language Editor

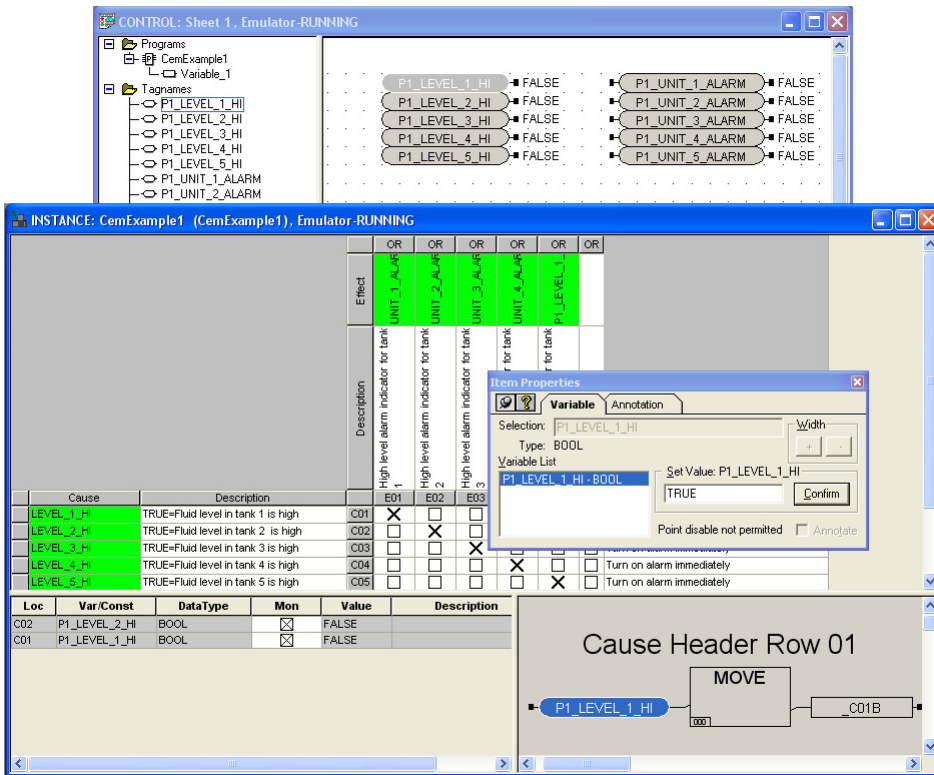

Instance View of a Matrix

The FBD network uses internal boolean variables to save and move results to associated cells so that causes and effects can be evaluated. For each cause, effect, and intersection, an internal variable is automatically created to store and move results between cells.

## Variable Detail Table

The Variable Detail Table displays the inputs and outputs of the FBD Network that are generated when a cause, effect, or intersection is selected.

The variable type and data type can also be specified from the Variable Detail Table.

## Developing a Matrix

A matrix created in CEMPLE can be as basic or complex as the situation

requires. In a basic matrix, causes are identified as true or false inputs related to one or more effects through the intersections between them. The state of a cause (true or false) determines the state of the related effect. If more than one cause is related to an effect, the state of the effect is based on how the matrix is evaluated.

The effect state can be determined in either of two ways: by a logical AND operation or by a logical OR operation on the intersection. A logical AND is typically used for de-energize to trip systems; a logical OR is typically used for energize to trip systems.

## Using Functions and Function Blocks

For more complex processes, CEMPLE enables functions and function blocks to be added to causes, effects, and intersections. This feature can be used for

many purposes, such as; evaluation of process input to determine the cause state, calculating one or more process variable values based on the state of an effect, and using time delays.

User-created functions and function blocks, must be created and enabled for use before they can be included in a matrix.

## Testing and Monitoring

Like all TriStation 1131 programs, a matrix can be tested and debugged off-line using the Emulator Control Panel. After the project is downloaded, the Control Panel can be used to monitor the values of variables during real-time execution.

In an instance view of a matrix, active causes, intersections, and effects can be viewed in a choice of colors.

As with other types of executable elements, values and variables can be set for use during emulation and real-time execution.

## CEMPLE Tools

A matrix can be developed and edited using a variety of graphical interface methods. Commands can be selected from a main menu, toolbar, and pop-up menu.

Variables can be added or renamed by making changes in the Variable Detail Table. Where appropriate, drop-down lists provide variable names or function and function block names to be selected.

For more information, see the *TriStation 1131 Developer's Guide*.

*During each scan of the control program, the Main Processors examine selected discrete variables for state changes known as events.*

## Sequence of Events (SOE) Capability

Triconex systems support the ability to report, by exception, events that are significant in your application. This capability, called Sequence of Events (SOE), includes the following parts:

- Defining the discrete data items to be monitored through the TriStation 1131 application
- Monitoring and collecting events by the Triconex controller
- Retrieving the events from the Triconex controller using a host system

The following host systems can be used to retrieve event data:

- Triconex SOE Recorder, a Windows-based application that runs on a PC
- Safety Manager Module (SMM) for Honeywell DCS systems
- Advanced Communication Module (ACM) for Foxboro DCS systems
- An OPC client control program which has implemented the Alarm and Events Handler as specified in the OPC standard version 1.0

With the Triconex SOE Recorder software you can:

- Collect and analyze event data
- Export event database files
- Print reports with event data

The SOE data file, which is output from the TriStation 1131 software, is only for use with Triconex SOE Recorder. This file is read by the software and adds descriptive information which is

associated with the tagname in the Configuration file in the TriStation 1131 software.

### Preparing Your System for Event Collection

To enable the controller to detect events, event variables and SOE blocks are identified in the TriStation 1131 project. In addition, the project must include an SOE function block that starts the event collection.

After an SOE-enabled project is downloaded to the controller, the TriStation 1131 software creates an SOE definition file that contains the SOE block definitions.

When the SOE software collects an event from the controller, it obtains the tagname, alias, state name, and other

information about the event variable from the SOE definition file.

These tasks are done in the TriStation 1131 software:

- Defining SOE blocks with buffer size and block types
- Assigning event variables to the SOE blocks
- Adding SOE function blocks to the program logic

### Types of Event Variables

The types of discrete variables that can be designated as event variables are:

- BOOL input
- BOOL aliased memory variables

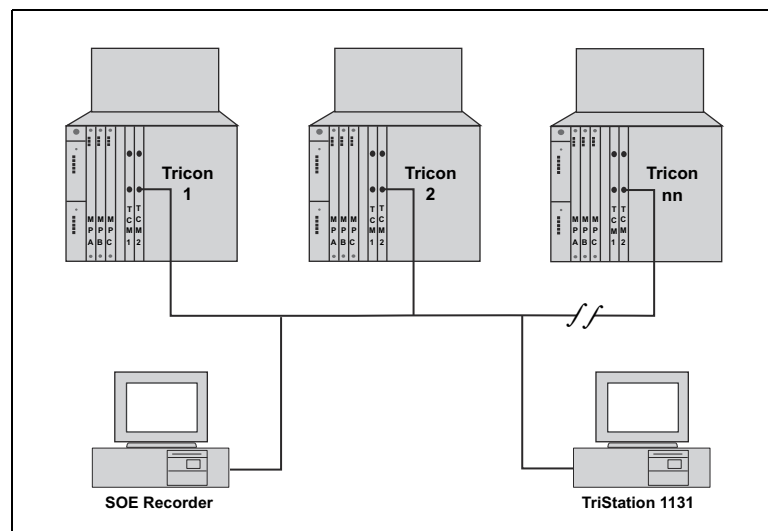

Tricon Network with SOE PC

# Sequence of Events (SOE) Capability

## Configuring SOE Blocks

An SOE block is a data structure that resides in the memory of a controller's Main Processors. When SOE blocks are configured, the event variables to be detected by the controller are specified for each block.

The maximum individual block size is 20,000 events, with 60,000 events for all blocks. The block size is the amount of memory that the Main Processors reserve for recording of events.

When a block is collecting events, the Main Processors write an event entry which includes the values of event variables that changed during the current scan and a time stamp.

### SOE Function Blocks

SOE function blocks control and verify event collection for SOE blocks. The following function blocks are available:

- SOESTRT starts event collection
- SOESTOP stops event collection
- SOESTAT checks status of SOE blocks
- SOECLR clears status of SOE blocks

The SOESTRT function block must be added to the TriStation 1131 program to identify the SOE blocks from which events are to be collected. The other SOE function blocks are optional.

### SOE Software

SOE software can simultaneously collect event data from as many as 31 networked controllers. It queries all the controllers on the network to determine which downloaded TriStation 1131 projects include SOE blocks. If a project includes one or more SOE blocks, the software opens the appropriate SOE definition file and begins collecting events from the associated controller.

| Date       | Time         | Alias | TagName     | Vari... | Node           | Block            |
|------------|--------------|-------|-------------|---------|----------------|------------------|
| 08/24/2000 | 21:14:41.246 | 02001 | EVENT_VAR1  | ON      | 06 - TRINODE06 | 01 - soe_block_1 |
| 08/24/2000 | 21:14:41.246 | 02002 | EVENT_VAR2  | OFF     | 06 - TRINODE06 | 01 - soe_block_1 |
| 08/24/2000 | 21:14:41.246 | 02003 | EVENT_VAR3  | ON      | 06 - TRINODE06 | 01 - soe_block_1 |
| 08/24/2000 | 21:14:41.246 | 02004 | EVENT_VAR4  | OFF     | 06 - TRINODE06 | 01 - soe_block_1 |
| 08/24/2000 | 21:14:41.246 | 02005 | EVENT_VAR5  | ON      | 06 - TRINODE06 | 01 - soe_block_1 |
| 08/24/2000 | 21:14:41.246 | 02006 | EVENT_VAR6  | OFF     | 06 - TRINODE06 | 01 - soe_block_1 |
| 08/24/2000 | 21:14:41.246 | 02007 | EVENT_VAR7  | ON      | 06 - TRINODE06 | 01 - soe_block_1 |
| 08/24/2000 | 21:14:41.246 | 02008 | EVENT_VAR8  | OFF     | 06 - TRINODE06 | 01 - soe_block_1 |
| 08/24/2000 | 21:14:41.246 | 02009 | EVENT_VAR9  | OFF     | 06 - TRINODE06 | 01 - soe_block_1 |
| 08/24/2000 | 21:14:41.246 | 02010 | EVENT_VAR10 | ON      | 06 - TRINODE06 | 01 - soe_block_1 |
| 08/24/2000 | 21:14:41.246 | 02011 | EVENT_VAR11 | OFF     | 06 - TRINODE06 | 01 - soe_block_1 |
| 08/24/2000 | 21:14:41.246 | 02012 | EVENT_VAR12 | ON      | 06 - TRINODE06 | 01 - soe_block_1 |
| 08/24/2000 | 21:14:41.246 | 02013 | EVENT_VAR13 | OFF     | 06 - TRINODE06 | 01 - soe_block_1 |
| 08/24/2000 | 21:14:41.246 | 02014 | EVENT_VAR14 | ON      | 06 - TRINODE06 | 01 - soe_block_1 |
| 08/24/2000 | 21:14:41.246 | 02015 | EVENT_VAR15 | OFF     | 06 - TRINODE06 | 01 - soe_block_1 |
| 08/24/2000 | 21:14:41.246 | 02016 | EVENT_VAR16 | ON      | 06 - TRINODE06 | 01 - soe_block_1 |
| 08/24/2000 | 21:14:41.246 | 02017 | EVENT_VAR17 | OFF     | 06 - TRINODE06 | 01 - soe_block_1 |
| 08/24/2000 | 21:14:41.246 | 02018 | EVENT_VAR18 | ON      | 06 - TRINODE06 | 01 - soe_block_1 |
| 08/24/2000 | 21:14:41.246 | 02019 | EVENT_VAR19 | OFF     | 06 - TRINODE06 | 01 - soe_block_1 |

SOE Events File

While the TriStation 1131 project is running, the SOE software can be used to analyze events online as it collects them from the controllers. Snapshots of events that cover specific periods of time before or after trips have occurred can also be saved.

To analyze the event data, the Triconex SOE Recorder software includes tools for these tasks:

- Finding events and copying them to other Windows-based applications
- Filtering and sorting saved event data
- Specifying the display of point properties for event data
- Viewing the properties of individual events

SOE Recorder also allows event data to be exported to database or ASCII text files, either manually or automatically. A report engine and standard report are included.

### Trip Processing

A trip is a shutdown of the controlled process, or a portion of the controlled process. A TriStation 1131 project used for safety shutdown typically includes one trip variable, whose state change initiates the shutdown activities. If a project requires several variables

related to trip conditions, these variables must be evaluated in combination to determine the final state of the trip variable. When a trip event occurs, the SOE software can automatically create a trip snapshot. This snapshot is a file of events that occurred *x* minutes before a trip and *y* minutes after a trip, based on the settings in the TriStation 1131 software.

### Time Synchronization and Time Stamps

In a typical Peer-to-Peer network, the controllers synchronize their time with the master node (the controller with the lowest node number) within ±25 milliseconds. A controller recognizes events on a scan basis and time-stamps each event at the beginning of the scan.

Because the scans of the various controllers on the network are not synchronized, the same event can be logged by two controllers with different time stamps. The worst-case difference is the longer scan time plus 25 milliseconds.

Each day, the SOE software compares its clock with the clock of each controller from which event data is being collected. If a controller's clock is out of sync by more than five minutes, a message is displayed in the SOE message bar.

*Triconex Safety View ABM allows you to monitor and manage safety alarms.*

## Safety View ABM

Triconex Safety View Alarm and Bypass Management (ABM) is part of the Triconex Safety View suite of applications. Safety View ABM is used to monitor and acknowledge safety alarms, and bypass tagnames. The safety alarms are generated from field devices connected to the safety controllers, and represent conditions impacting the safety of the equipment under control. Safety View ABM also displays the current alarm state and process condition for all configured tagnames. The user interface, configurability, and bypass capabilities make Safety View ABM superior to traditional safety monitoring tools.

Safety View ABM supports compliance with NERC cyber security requirements, and is TÜV-approved for use with SIL3 safety systems per IEC 61508 and IEC 61511. Safety View ABM can be used with the following Triconex controllers:

- Tricon v9.x and later
- Trident v1.x and later
- Triconex General Purpose (Tri-GP) v2.x and later

Safety View ABM v1.0.0 supports the following Windows operating systems:

- Windows Server® 2003
- Windows Server 2008 SP2 (32-bit and 64-bit)
- Windows XP Professional SP3
- Windows 7 Professional (32-bit and 64-bit)

### Functional Overview

Safety View ABM depends on the implementation of process alarms in the safety controller using TriStation 1131.

Safety View ABM supports alarm states and sequences as defined in the *ISA 18.1 - 2004 (R)-Annunciator Sequences and Specifications* standard.

Safety View ABM allows you to:

- Configure tagnames for alarm monitoring
- Monitor alarms generated from controllers
- Retrieve alarm-related data from up to 63 controllers simultaneously

Safety View ABM is comprised of several components, including the following:

- **Configuration Component:** The Safety View Configuration Component allows you to add, delete, update, import, and export configuration settings for controllers, users, tagnames, alarms, and monitoring workstations. Once configuration is complete, you deploy the Alarm Monitoring Application to the monitoring workstations.
- **Safety View Server:** The Safety View server manages communication with the controller, the Safety View database, and the Alarm Monitoring Application. The server sends commands from the Alarm Monitoring Application to the controller for processing and to the database for storage. The server

also retrieves alarm and process condition information continuously from the configured controllers and displays the collected information in the Alarm Monitoring Application even when no user is logged on.

- **Safety View Database:** The Safety View database stores configuration information, alarm state data, and security information from the Configuration Component, the Alarm Monitoring Application, and the controllers.
- **Alarm Monitoring Application:** The Alarm Monitoring Application is a managed InTouch® application that is deployed to monitoring workstations via the Configuration Component. It allows you to perform a number of alarm management functions.

The Safety View ABM components are installed on designated PCs or servers in the supervisory network. The Invensys Arcestra™ framework maintains the Safety View ABM components and serves as the underlying infrastructure that supports Safety View ABM.

# Safety View ABM

## Alarm Monitoring Application Features

The Safety View ABM Alarm Monitoring Application allows a plant operator to view, manage, and bypass tagnames and safety alarms. It continually updates alarm states and process conditions even when an operator is not logged in; user authentication is required to perform any operation. The Shift Change functionality re-activates all alarms acknowledged by an operator during the previous work shift.

The Safety View ABM Alarm Monitoring Application allows you to:

- Acknowledge individual and group alarms
- Re-activate alarms acknowledged by an operator during the previous work shift
- Clear first-out alarms
- Bypass and unbypass tagnames
- Add and review notes for bypassed tagnames
- Silence audible alarms
- Reset alarms in the ringback state
- Print audit trail records

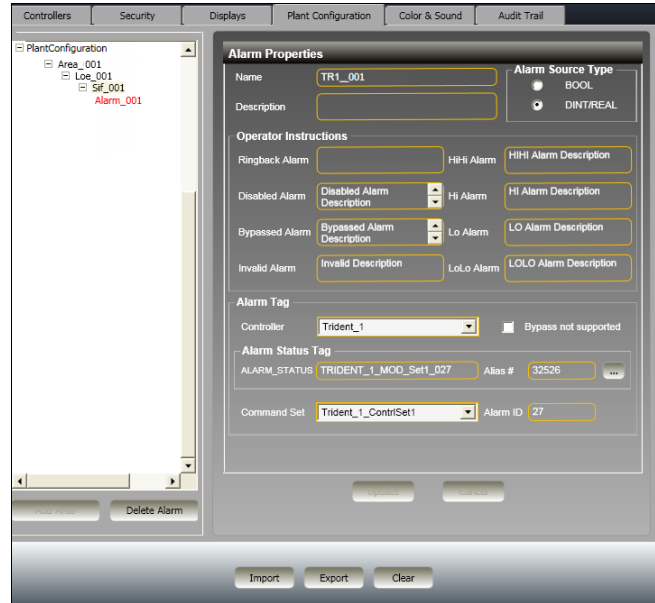

Example of the Configuration Component Interface

## Configuration Component Features

The Safety View ABM Configuration Component is an ArchestrA object that is accessed from the ArchestrA IDE. It allows you to add, delete, update, import, and export configuration settings for the following:

- Safety controllers
- Users, roles, and security permissions
- Monitoring workstations and their corresponding displays
- Areas, lines of equipment (LoEs), safety instrumented functions (SIFs), and field devices
- Alarm colors and sounds
- Audit trail network printer

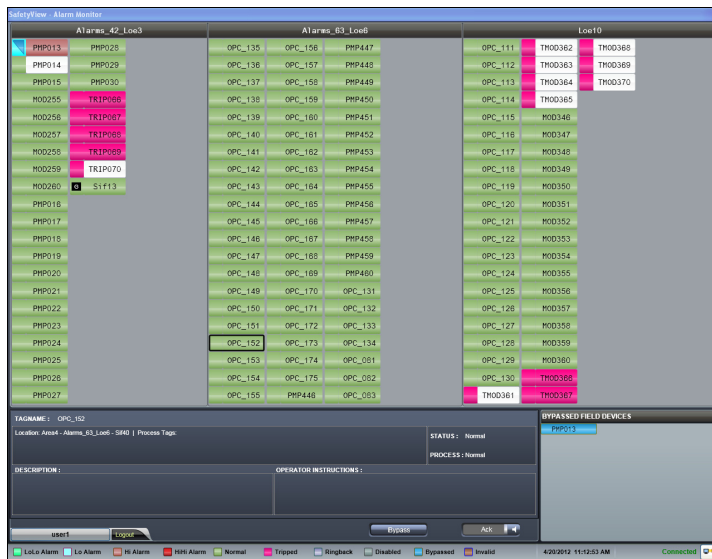

Example of the Alarm Monitoring Application Interface

# *Part Number Cross-Reference*

The table below identifies the external termination assembly (ETA) part number and the cable part number for each termination panel model number.

There are four cable types included in this table:

- **FT4:** Ninety-degree cables that meet FT4 flame test ratings. Add “F” at the end of the base model number to obtain the complete model number. For example, 9551-110F.
- **Z:** Zero-degree cables, designed to be used with G-Series Enclosures for Tricon systems that have front access. Add “F-Z” at the end of the base model number to obtain the complete model number. For example, 9551-110F-Z.
- **LSZH:** Low Smoke Zero Halogen ninety-degree cables. Add “J” at the end of the base model number to obtain the complete model number. For example, 9551-110J.
- **FT1:** Ninety-degree cables that were shipped with pre-FT4 ETP models. These models did not include a letter at the end of the base model number.

## Part Number Cross-Reference—ETPs

| Base Model # | ETA         | FT4 Cable   | Z Cable     | LSZH Cable  | FT1 Cable (Old) |
|--------------|-------------|-------------|-------------|-------------|-----------------|
| 9551-110     | 3000400-160 | 4000187-110 | 4000192-110 | 4000140-110 | 4000093-110     |
| 9552-610     | 3000400-260 | 4000187-210 | 4000192-210 | 4000140-210 | 4000093-210     |
| 9553-610     | 3000400-360 | 4000187-310 | 4000192-310 | 4000140-310 | 4000093-310     |
| 9561-110     | 3000560-110 | 4000187-110 | 4000192-110 | 4000140-110 | 4000093-110     |
| 9561-810     | 3000510-180 | 4000187-110 | 4000192-110 | 4000140-110 | 4000093-110     |
| 9562-810     | 3000510-280 | 4000187-210 | 4000192-210 | 4000140-210 | 4000093-210     |
| 9563-810     | 3000510-380 | 4000187-310 | 4000192-310 | 4000140-310 | 4000093-310     |
| 9563-910     | 3000510-390 | 4000187-310 | 4000192-310 | 4000140-310 | 4000093-310     |
| 9565-810     | 3000540-280 | 4000187-210 | 4000192-210 | 4000140-210 | 4000093-210     |
| 9566-710     | 3000530-380 | 4000187-310 | 4000192-310 | 4000140-310 | 4000093-310     |
| 9566-810     | 3000540-380 | 4000187-310 | 4000192-310 | 4000140-310 | 4000093-310     |
| 9570-610     | 3000768-370 | 4000195-310 | 4000199-310 | n/a         | 4000165-310     |
| 9571-610     | 3000768-390 | 4000195-310 | 4000199-310 | n/a         | 4000165-310     |
| 9572-610     | 3000771-380 | 4000195-310 | 4000199-310 | n/a         | 4000165-310     |
| 9651-110     | 3000410-160 | 4000188-110 | 4000193-110 | 4000141-110 | 4000094-110     |
| 9652-610     | 3000410-260 | 4000188-210 | 4000193-210 | 4000141-210 | 4000094-210     |
| 9653-610     | 3000410-360 | 4000188-310 | 4000193-310 | 4000141-310 | 4000094-310     |
| 9661-110     | 3000570-110 | 4000188-110 | 4000193-110 | 4000141-110 | 4000094-110     |
| 9661-510     | 3000550-160 | 4000188-110 | 4000193-110 | 4000141-110 | 4000094-110     |

# Part Number Cross-Reference

## Part Number Cross-Reference—ETPs (continued)

| Base Model # | ETA         | FT4 Cable   | Z Cable     | LSZH Cable  | FT1 Cable (Old) |
|--------------|-------------|-------------|-------------|-------------|-----------------|
| 9661-610     | 3000520-160 | 4000188-110 | 4000193-110 | 4000141-110 | 4000094-110     |
| 9661-810     | 3000550-180 | 4000188-110 | 4000193-110 | 4000141-110 | 4000094-110     |
| 9661-910     | 3000520-180 | 4000188-110 | 4000193-110 | 4000141-110 | 4000094-110     |
| 9662-110     | 3000570-310 | 4000188-310 | 4000193-310 | 4000141-310 | 4000094-310     |
| 9662-610     | 3000520-390 | 4000188-310 | 4000193-310 | 4000141-310 | 4000094-310     |
| 9662-710     | 3000550-390 | 4000188-310 | 4000193-310 | 4000141-310 | 4000094-310     |
| 9662-810     | 3000520-380 | 4000188-310 | 4000193-310 | 4000141-310 | 4000094-310     |
| 9662-910     | 3000550-380 | 4000188-310 | 4000193-310 | 4000141-310 | 4000094-310     |
| 9663-610     | 3000725-160 | 4000188-110 | 4000193-110 | 4000141-110 | 4000094-110     |
| 9664-110     | 3000726-110 | 4000188-110 | 4000193-110 | 4000141-110 | 4000094-110     |
| 9664-810     | 3000520-170 | 4000188-110 | 4000193-110 | 4000141-110 | 4000094-110     |
| 9667-110     | 3000570-710 | 4000188-210 | 4000193-210 | 4000141-210 | 4000094-210     |
| 9667-810     | 3000520-280 | 4000188-210 | 4000193-210 | 4000141-210 | 4000094-210     |
| 9667-910     | 3000550-280 | 4000188-210 | 4000193-210 | 4000141-210 | 4000094-210     |
| 9668-110     | 3000590-110 | 4000188-110 | 4000193-110 | 4000141-110 | 4000094-110     |
| 9670-110     | 3000290-110 | 4000203-110 | 4000204-110 | n/a         | 4000111-110     |
| 9670-610     | 3000290-160 | 4000203-110 | 4000204-110 | n/a         | 4000111-110     |
| 9671-610     | 3000769-390 | 4000196-310 | 4000200-310 | n/a         | 4000166-310     |
| 9671-810     | 3000290-380 | 4000203-310 | 4000204-310 | n/a         | 4000111-310     |
| 9672-810     | 3000290-280 | 4000203-210 | 4000204-210 | n/a         | 4000111-210     |
| 9673-810     | 3000290-181 | 4000203-110 | 4000204-110 | n/a         | 4000111-110     |
| 9750-210     | 3000420-120 | 4000206-510 | 4000207-510 | n/a         | 4000093-510     |
| 9750-310     | 3000420-310 | 4000187-310 | 4000192-310 | 4000140-310 | 4000093-310     |
| 9750-410     | 3000420-410 | 4000187-210 | 4000192-210 | 4000140-210 | 4000093-210     |
| 9750-810     | 3000420-180 | 4000206-510 | 4000207-510 | n/a         | 4000093-510     |
| 9753-110     | 3000400-510 | 4000189-510 | 4000191-510 | 4000142-510 | 4000103-510     |
| 9760-210     | 3000470-510 | 4000206-510 | 4000207-510 | n/a         | 4000093-510     |
| 9760-410     | 3000470-530 | 4000206-510 | 4000207-510 | n/a         | 4000093-510     |
| 9761-210     | 3000510-510 | 4000189-510 | 4000191-510 | 4000142-510 | 4000103-510     |
| 9761-410     | 3000510-530 | 4000189-510 | 4000191-510 | 4000142-510 | 4000103-510     |
| 9762-210     | 3000510-560 | 4000189-510 | 4000191-510 | 4000142-510 | 4000103-510     |

**Part Number Cross-Reference—ETPs** *(continued)*

| Base Model # | ETA                        | FT4 Cable   | Z Cable     | LSZH Cable  | FT1 Cable (Old) |
|--------------|----------------------------|-------------|-------------|-------------|-----------------|
| 9762-410     | 3000510-580                | 4000189-510 | 4000191-510 | 4000142-510 | 4000103-510     |
| 9763-810     | 3000580-110                | 4000189-510 | 4000191-510 | 4000142-510 | 4000103-510     |
| 9764-310     | 3000712-200                | 4000189-510 | 4000191-510 | 4000142-510 | 4000103-510     |
| 9765-210     | 3000475-520                | 4000206-510 | 4000207-510 | n/a         | 4000093-510     |
| 9765-610     | 3000580-230                | 4000189-510 | 4000191-510 | 4000142-510 | 4000103-510     |
| 9766-210     | 3000580-210                | 4000189-510 | 4000191-510 | 4000142-510 | 4000103-510     |
| 9766-510     | 3000580-220                | 4000189-510 | 4000191-510 | 4000142-510 | 4000103-510     |
| 9771-210     | 3000656-210                | 4000189-510 | 4000191-510 | 4000142-510 | 4000103-510     |
| 9782-110     | 3000767-280                | 4000189-510 | 4000191-510 | 4000142-510 | 4000103-510     |
| 9783-110     | 3000767-160                | 4000189-510 | 4000191-510 | 4000142-510 | 4000103-510     |
| 9784-610     | 3000767-220                | 4000197-510 | 4000201-510 | n/a         | 4000164-510     |
| 9785-610     | 3000767-210                | 4000197-510 | 4000201-510 | n/a         | 4000164-510     |
| 9786-110     | 3000767-230                | 4000197-510 | 4000201-510 | n/a         | 4000164-510     |
| 9787-110     | 3000767-110                | 4000197-510 | 4000201-510 | n/a         | 4000164-510     |
| 9789-610     | 3000768-510                | 4000209-510 | 4000208-510 | n/a         | 4000165-510     |
| 9790-610     | 3000771-560                | 4000189-510 | 4000191-510 | 4000142-510 | 4000103-510     |
| 9791-610     | 3000771-510                | 4000197-510 | 4000201-510 | 4000142-510 | 4000164-510     |
| 9792-610     | 3000772-660                | 4000191-510 | 4000201-510 | 4000142-510 | 4000103-510     |
| 9793-110     | 3000767-115                | 4000201-510 | 4000191-510 | n/a         | 4000164-510     |
| 9794-110     | 3000767-165                | 4000189-510 | 4000191-510 | 4000142-510 | 4000103-510     |
| 9795-610     | 3000771-460                | 4000191-510 | 4000194-510 | 4000142-510 | 4000103-510     |
| 9853-610     | 3000400-530                | 4000190-510 | 4000194-510 | 4000157-510 | 4000098-510     |
| 9860-610     | 3000770-610                | 4000194-510 | 4000202-510 | 4000157-510 | 4000098-510     |
| 9861-610     | 3000770-560                | 4000202-510 | 4000194-510 | n/a         | 4000163-510     |
| 9863-710     | 1600049-010<br>1600049-100 | 4000194-510 | 4000202-510 | 4000157-510 | 4000098-510     |
| 9871-810     | 3000818-560                | 4000202-510 | 4000194-510 | n/a         | 4000163-510     |
| 9881-810     | 3000818-660                | 4000194-510 | 4000192-110 | 4000157-510 | 4000098-510     |



---

# Glossary

---

**Ω**

The symbol which represents ohm.

**μ**

The symbol which represents micro.

**A**

Abbreviation for amp.

*alias*

A five-digit number which identifies the data type and hardware address of a point in the Triconex controller. Alias is a convention of Modbus which is a communication protocol available with Triconex communication modules.

*control program*

A control program is the compiled code (built from program elements and configuration information in a TriStation 1131 project) that is downloaded to and runs in a Triconex controller.

*ASIC*

Stands for Application Specific Integrated Circuit.

*ATEX*

Stands for “Atmosphères Explosibles” and refers to the European Union Directive 94/9/EC, which is one of a number of new approach directives developed by the European Union and covers all equipment and protective systems intended for use in potentially explosive atmospheres.

*availability*

The probability that the control system is operational at some instance of time.

*bin*

An address range of aliased variables in Triconex controllers, based on Class and Type combinations.

*board*

See *module*.

*card*

See *module*.

*cause*

In CEM methodology, a cause is a problem to be solved by the matrix.

*CEM*

Stands for Cause and Effect Matrix which is a two-dimensional matrix for the development of safety control programs. In this type of matrix, causes are represented by rows and effects are represented by columns.

*CE Mark*

A type of certification by the European Union which ensures the electro-magnetic compatibility of Triconex controllers with other pieces of electrical and electronic equipment.

*CEMPLE*

A language editor in the TriStation 1131 Developer's Workbench that allows you to develop CEMs for safety shutdown applications.

*communication modules*

Modules that enable the Triconex controllers to communicate with host computers. Invensys offers communication modules with Ethernet and serial protocol.

*configuration*

In the TriStation 1131 software, the modules and settings used in a Triconex controller, including Main Processors, communication and I/O modules, field termination panels, and memory and module settings.

*control system*

The system which governs the operation of plant, machinery, or other equipment by producing appropriate instructions in response to input signals.

*controller*

A Triconex controller includes Main Processors, communication and I/O modules, and field termination devices.

*DCS*

Stands for distributed control system, which is a system that controls a process and provides status information to an operator.

# Glossary

---

## *DDE*

Stands for Dynamic Data Exchange (DDE) which is an interprocess communication mechanism provided by Microsoft Windows. Windows-based applications can use DDE to send and receive data and instructions to and from each other.

## *debug*

The act of locating and correcting faults: 1) one of the normal operations in software development such as editing, compiling, debugging, loading, and verifying; or 2) the identification and isolation of a faulty physical component, including its replacement or repair to return the PLC to operational status.

## *effect*

In CEM methodology, an effect is an action that must be taken to solve a cause (problem).

## *event*

A state change of a discrete aliased variable which has been designated for event logging. An event occurs when a variable changes from the normal state to another state.

## *event logger*

A utility that logs, displays, and prints critical events in real time, based on state changes of discrete variables in the user-written control program. Proper use of an event logger warns users about dangerous conditions and print-outs of events can help identify the sequence of events that led to a trip.

## *event variable*

A discrete memory variable or discrete input point that has been assigned to an SOE block.

## *external device*

A device (PC, server, printer, or other device) that communicates with the Tricon controller over a network.

## *fault tolerance*

The ability to identify and compensate for failed control system elements and allow repair while continuing an assigned task without process interruption. Fault tolerance is achieved by incorporating redundancy and fault masking.

## *FBD*

Stands for Function Block Diagram which is a graphical programming language that corresponds to circuit diagrams. Used for connective programming, FBD

programs are structured by groups of interconnected elements (networks), allowing the integration of function and function blocks.

## *HART*

Highway Addressable Remote Transducer protocol is a bi-directional industrial field communication protocol used to communicate between intelligent field instruments and host systems over 4–20 mA instrumentation wiring.

## *hazardous location*

Any location that contains, or has the potential to contain, an explosive or flammable atmosphere.

## *host*

See *external device*.

## *hot-spare*

A unique feature of Triconex controllers which allows spare I/O modules to be installed with automatic switch to the spare in case the primary module fails.

## *IEEE*

Stands for the Institute of Electrical and Electronics Engineers (IEEE) which is a professional society for engineers.

## *IEC 61131-3*

The part of the IEC 61131 standard for programmable controllers that specifies the syntax and semantics of a unified suite of programming languages for programmable controllers.

## *input poll time*

The time required by the Triconex controller to collect input data from the controlled process. Input polling is asynchronous and overlaps execution of the user-written control program.

## *instance view*

In the TriStation 1131 software, the Emulator Control Panel and Triconex Control Panel displays the values of annotated variables while a TriStation 1131 project is running. In an instance view, you can change the values of variables during emulation or real-time execution.

## *intermittent fault*

A fault or error that is only occasionally present due to unstable hardware or varying software states.

## Glossary

### *intersection*

In CEMPLE, a cell in a matrix where a cause row intersects an effect column.

### *intersection function*

In CEMPLE, a function or function block that can be selected from a list in the Intersection cell of a cause row and an effect row.

### *ISO*

Stands for the International Organization for Standardization (ISO) which is a worldwide federation of national standards bodies (ISO member bodies) that promulgates standards affecting international commerce and communications.

### *LD*

Stands for Ladder Diagram, which is a graphical programming language that uses a set of symbols to represent relay logic. Modules are defined by their connection to a left and right power rail.

### *logical slot*

In a Triconex chassis, a logical slot is a repository for a primary module, a hot-spare module, and their associated field termination component.

### *m*

Abbreviation for milli.

### *Markov model*

A generalized modeling technique which can be used to represent a system with an arbitrary number of modules, failure events, and repair events. A Markov model can be mathematically solved to produce a resultant probability.

### *matrix*

1. A CEM program
2. A traditional methodology for ESD applications which associates a problem (cause) in a process with one or more actions (effects) that must be taken to correct the problem.

### *module*

An active field-replaceable unit consisting of an electronic circuit assembly housed in a metal spine. Also called *board* or *card*.

### *MTBF*

Stands for Mean Time Between Failure which is the expected average time between failures of a system,

including the time taken to repair the system. Usually expressed in hours.

### *MTTF*

Stands for Mean Time To Failure which is the expected average time to a system failure in a population of identical systems. Usually expressed in hours.

### *MTTR*

Stands for Mean Time To Repair which is the expected time to repair a failed system or subsystem. Usually expressed in hours.

### *node*

Any of the machines on a network. In this document, node usually means a Triconex controller.

### *node number*

The physical address of a node.

### *nonincendive*

Not capable of igniting a flammable gas or vapor under normal operating conditions.

### *open network*

A network to which an external host can be connected.

### *output poll time*

The time required by the Triconex controller to implement the outputs generated by the user-written control program in response to inputs from the controlled process.

### *Peer-to-Peer*

A protocol that allow multiple Triconex controllers on a proprietary network to exchange limited amounts of process and safety information.

### *program*

1. The set of instructions, commands, and/or directions that define the Triconex controller's output signals in terms of input signals.
2. The act of creating such a set of instructions using the relay ladder language of the TriStation 1131 programming software.

### *protocol*

A set of rules describing the format used for data exchange between two entities.

# Glossary

---

## *reliability*

The probability that no failure of the system will have occurred in a given period of time.

## *scan time*

The period of the Triconex controller's cycle of required control functions. Scan time is composed of three elements:

- Input poll time (asynchronous with execution of the user-written control program)
- The time required to execute the user-written control program
- Output poll time

## *ST*

Stands for Structured Text, which is a high-level programming language used for complex arithmetic calculations and procedures that are not easily expressed in graphical languages.

## *system*

Consists of a set of components which interact under the control of a design.

## *TCP/IP*

Stands for Transmission Control Protocol/Internet Protocol (TCP/IP) which are protocols for the Transport and Network layers of the OSI network model. TCP/IP provides reliable, sequenced data delivery.

## *Time Synchronization*

A Triconex protocol used to establish and maintain a synchronized, network-wide time basis. Time can be synchronized with the master node in a network of Tricon or Trident controllers, with a distributed control system (DCS), or with an OPC client/server control program.

## *transient fault*

A fault or error resulting from a temporary environmental condition.

## *TMR*

Stands for Triple-Modular Redundant architecture, which allows Triconex controllers to achieve fault tolerance. The complete system is triplicated; each of the three identical systems is called a leg. Each leg independently executes the user-written control program in parallel with the other legs.

## *trip*

A safety-related shutdown of the controlled process or a portion of the controlled process.

## *TriStation 1131*

Software for developing and downloading user-written control programs and for performing maintenance and diagnostics.

## *TriStation protocol*

A master/slave protocol used by the TriStation 1131 software for communication with Triconex controllers.

## *TÜV Rheinland*

TÜV stands for Technischer Überwachungs-Verein which translates to Technical Supervisory Association. In Germany, TÜV Rheinland is an authorized technical inspection agency for a wide variety of products, processes, installations, plants and equipment.

## *UDP/IP*

Stands for User Datagram Protocol/Internet Protocol (UDP/IP) which are protocols for the Transport and Network layers of the OSI network model. UDP/IP provides best-effort datagram delivery.

## *voting*

A mechanism whereby each leg of a TMR system compares and corrects the data in each leg using a two-out-of-three majority voting scheme.

# CONTACT US & SUPPORT

NEED A QUOTE OR TECHNICAL PARTS REPLACEMENT?

**Company:** [PLC ProTech Ltd.](#)  
**Website:** [www.plcprotech.com](http://www.plcprotech.com)  
**Email:** [sales@plcprotech.com](mailto:sales@plcprotech.com)  
**Phone:** +86 180 4631 7198

## Our Service Guarantee:

- 100% Brand New Original & Factory Sealed Components
- 12-Month Quality Warranty on All Industrial Parts
- Worldwide Same-Day Fast Dispatch via DHL / FedEx

[SUBMIT ONLINE RFQ \(REQUEST FOR QUOTE\) >>](#)

[About Us](#) · [Contact](#) · [All Products](#)