

Enabling the Extraordinary
To Fly To Power To Live

MEGGITT

SAFETY MANUAL

vibro-meter®

VM600
machinery protection system (MPS)

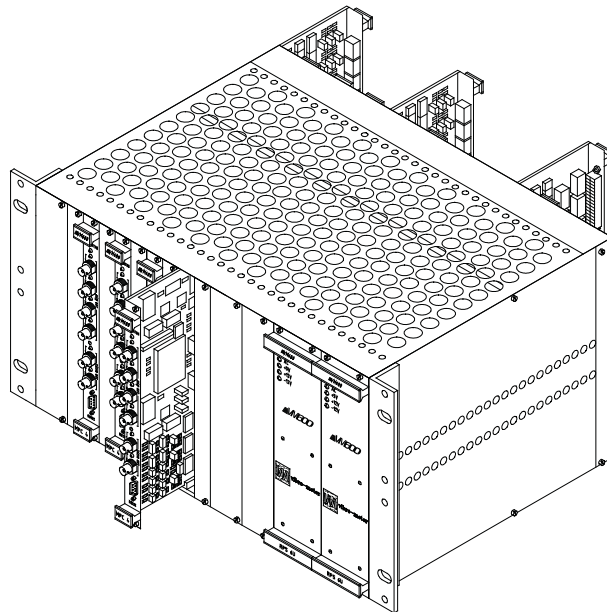

This document contains important information about products that are intended for use in safety-related applications.

Document reference MAVM600-FS/E
Edition 8 – September 2020

REVISION RECORD SHEET

Edition	Date of issue	Written by / modified by	Description	Signature
1	18.11.2009	Oliver Dixon / Peter Ward	First edition based on the document "VM600 safety manual release ver 00" which was approved by TÜV® NORD. This document has been edited to align with VM Energy publication standards.	OD / PW
2	03.05.2010	Peter Ward	In the first edition of this manual, in the SP5 row of Table 3-4: Safety parameters, the PFD figure for PT=1.0 should have read 1.1e-2 (not 1.1e-3). However, the SP5 row of this table has now been updated to use PFDavg figures (instead of PFD figures). This change is to support clients who calculate safety loops according to IEC 61508 / IEC 61511 and therefore use PFDavg calculations.	PW
3	06.08.2010	Peter Ward	Review Copy: Updated Table 1-2: Reference part numbers. Added new section 1.6 to explain the difference between 'standard' and 'safety' MPC4 cards. Added new section 1.6.1 to outline the permitted rack configurations. Added new section 1.7 to explain the verification of possible conflicts in card configurations. Updated Table 3-2: Overview of valid safety inputs and outputs.	PW
3	10.09.2010	Peter Ward	Review Copy 2: Deleted connection covers from Table 1-2. Cosmetic rewording to section 1.6. Additions to Table 1-4. Rewrite of section 1.7 to simplify and clarify configuration restrictions and requirements.	PW
4	07.02.2011	Peter Ward	Corrected some part numbers, updated 'standard' and 'safety' MPC4 card front panel images in section 1.6, updated TÜV NORD certificate in section 2, and clarified configuration verification procedure in section 3.9.4. Also updated in accordance with the latest Meggitt brand guidelines, with all references to InSight software changed to VibroSight® software.	PW

MEGGITT

Edition	Date of issue	Written by / modified by	Description	Signature
5	24.07.2014	Melina Brunet / Peter Ward	<p>Added a terminology section (Terminology) and clarified the difference between the VM600 MPS1 and MPS2 software.</p> <p>Updated Table 1-2 and Table 1-3 to use generic part numbers, where applicable.</p> <p>Updated Table 1-4 to reference the latest versions of the relevant manuals.</p> <p>Clarified the differences between the different versions of MPC4 card and which versions are certified by TÜV NORD (1.7 Different versions of the MPC4 card).</p> <p>Moved the SIL certificates from TÜV NORD to an appendix (Appendix A: Safety certificates).</p> <p>Clarified the sharing of safety relevant and non-safety relevant signals between VM600 cards (1.8 Avoiding possible conflicts from additional cards).</p> <p>Updated Table 1-8 to be more generic (that is, not safety-relevant specific).</p> <p>Clarified alarm and relay configuration requirements when a safety function is performed by an external system using an alarm detected by a VM600 system as an input (2.1 VM600 in a safety-related system).</p>	MB / PW
6	25.05.2015	Melina Brunet / Peter Ward	<p>Updated Table 2-1 to include the Dual mathematical function (DMF), which is certified as a valid processing mode for safety-related systems.</p> <p>Updated the proof test information to include the product lifetime and guidance on the replacement of MPC4SIL cards at the proof test interval (2.11 Proof test interval and product lifetime) including a new form (MPC4SIL card proof test interval form).</p> <p>Updated the maintenance information to remove the guidelines for the proof test as they are no longer required (2.12 Maintenance).</p> <p>Updated the failure report form to include the operating time before failure (Energy product return form).</p> <p>Added the latest SIL certificate from TÜV NORD to the appendix (Appendix A: Safety certificates).</p>	MB / PW

MEGGITT

Edition	Date of issue	Written by / modified by	Description	Signature
7	01.02.2018	Melina Brunet / Peter Ward	<p>Added a statement that Meggitt SA product certifications and warranties are valid only for products purchased directly from Meggitt SA or an authorised distributor (see Important notices).</p> <p>Updated product part numbers (PNRs) to reflect the latest RoHS versions of the MPC4, IOC4T and RLC16 cards (see Table 1-3 in 1.4 Reference part numbers).</p> <p>Updated the document editions to reflect the latest versions of the associated documentation (see Table 1-4 in 1.5 Related documentation).</p> <p>Clarified that the buffered (raw) outputs from the MPC4 card or the IOC4T card must not be used to share safety-relevant signals between VM600 cards (see 1.8 Avoiding possible conflicts from additional cards).</p> <p>Added alarm delay time configuration requirements when a safety function uses a VM600-rack based system alarm that is configured as latching (see 2.1 VM600 in a safety-related system and 2.9.2 Define the alarm outputs).</p> <p>Added the latest safety (SIL) certificate from TÜV NORD to the appendix (see Figure A-4 in Appendix A: Safety certificates).</p> <p>Updated to use the latest Meggitt vibro-meter® Energy website information.</p>	MB / PW
8	21.09.2020	Ricardo Madureira / Peter Ward	<p>Added a related documentation section to include data sheets and to refer to the latest versions of the associated documentation (see 1.5 Related documentation).</p> <p>Updated the applicable standards section (see 1.6 Applicable standards).</p> <p>Further clarified that the buffered (raw) outputs from the MPC4 and IOC4T cards can be used to share signals that are non-safety-relevant (see 1.8 Avoiding possible conflicts from additional cards).</p> <p>Clarified that speed/phase reference (tachometer) processing can be performed but that the results must not be used for any safety-relevant functionality and that the speed/phase reference (tachometer) buffered (TTL) outputs from the MPC4 card and the VM600 rack's Tacho Bus must not be used to share safety-relevant signals (see 2.3 Safety inputs and outputs).</p> <p>Updated the Energy product return procedure and form to be consistent with the Meggitt vibro-meter® Energy website (see 4 Service and support).</p> <p>Updated to use the latest Meggitt brand identity and for consistency with other vibro-meter® safety manuals.</p>	RM / PW

MEGGITT

	Department	Name	Date	Signature
Technical content approved by	Systems and Safety	Ricardo Madureira	21.09.2020	RM
	Functional Safety	François Favre	21.09.2020	FF
	Product Line Management	Michaël Hafner	21.09.2020	MH
Document released by	Technical Publications	Peter Ward	21.09.2020	PW

The duly signed master copy of this page is stored by the Technical publications department of Meggitt SA and can be obtained by writing to Technical Publications.

MEGGITT

IMPORTANT NOTICES

All statements, technical information, and recommendations in this document which relate to the products supplied by Meggitt vibro-meter® (Meggitt SA) are based on information believed to be reliable, but unless otherwise expressly agreed in writing with Meggitt SA the accuracy or completeness of such data is not guaranteed. Before using this product, you must evaluate it and determine if it is suitable for your intended application. You should also check our website at www.meggittsensing.com/energy for any updates to data sheets, Ex certificates, product drawings, user manuals, service bulletins and/or other instructions affecting the product.

Unless otherwise expressly agreed in writing with Meggitt SA, you assume all risks and liability associated with use of the product. Meggitt SA takes no responsibility for any statements related to the product which are not contained in a current English language Meggitt SA publication, nor for any statements contained in extracts, summaries, translations or any other documents not authored and produced by Meggitt SA.

The certifications and warranties applicable to the products supplied by Meggitt SA are valid only for new products purchased directly from Meggitt SA or from an authorised distributor of Meggitt SA. Meggitt SA reserves the right to alter any part of this publication without prior notice.

EXPORT CONTROL

The information contained in this document may be subject to export control regulations of the European Community, USA or other countries. Each recipient of this document is responsible for ensuring that the transfer or use of any information contained in this document complies with all relevant export control regulations. ECN N/A.

COPYRIGHT

Copyright© 2009-2020 Meggitt SA

All rights reserved.

Published and printed by Meggitt SA in Fribourg, Switzerland.

The names of actual companies and products mentioned herein may be the trademarks of their respective owners.

The information contained in this document is subject to change without notice. This information shall not be used, duplicated or disclosed, in whole or in part, without the express written permission of Meggitt SA (Meggitt vibro-meter®).

MEGGITT

PREFACE

About this manual

This manual provides reference information on using VM600-rack based systems, from Meggitt's vibro-meter[®] product line, in safety-related applications (functional safety contexts).

It is applicable to the following VM600-rack based monitoring and protection systems:

- Machinery protection system (MPS).

About Meggitt and vibro-meter[®]

Meggitt PLC is a global engineering group, headquartered in the UK, specialising in the design and manufacture of high-performance components and systems for aerospace and energy markets.

The Meggitt facility in Fribourg, Switzerland, operates as the legal entity Meggitt SA (formerly Vibro-Meter SA). Vibro-meter[®] is a product line of Meggitt that applies our core sensing and monitoring technologies to power generation, oil & gas and other industrial markets.

Meggitt SA produces a wide range of vibration, dynamic pressure, proximity, air-gap and other sensors capable of operation in extreme environments, electronic monitoring and protection systems, and innovative software for aerospace and land-based turbomachinery.

Vibro-Meter[®] products and solutions have been at the forefront of sensing and monitoring for more than 65 years and help keep machinery and equipment working safely, reliably and efficiently. This includes the VM600-rack based systems produced for the Meggitt vibro-meter[®] product line.

To learn more about Meggitt Switzerland, our proud tradition of innovation and excellence, and our solutions for energy markets and applications, visit the www.meggittsensing.com/energy website.

Who should use this manual?

This manual is intended for personnel such as designers and operators of process monitoring and process control systems using VM600-rack based systems in safety-related applications.

The system designers and operators are assumed to have the necessary technical training in safety, reliability, electronics and/or mechanical engineering (professional certificate/diploma or equivalent) to enable them to design, install, configure, use and maintain such a system (safety instrumented system or SIS) that performs a safety function.

Structure of the manual

This section gives an overview of the structure of the document and the information contained within it. Some information has been deliberately repeated in different sections of the document to minimize cross-referencing and to facilitate understanding through reiteration.

The chapters are presented in a logical order. You should read those that are most relevant to you and then keep the document at hand for future reference.

The structure of the document is as follows:

Chapter 1	Introduction Explains the purpose and scope of this document.
Chapter 2	Safety issues Provides information on the safety issues related to the use of a VM600-rack based system in a safety-related application (functional safety context).
Chapter 3	End-of-life product disposal Provides advice on how to dispose of your electrical and electronic equipment at the end of its life.
Chapter 4	Service and support Provides contact details for technical queries and for getting equipment repaired. Includes a customer feedback form allowing the user to provide us with valuable feedback on our documentation.
Appendix A	Safety certificates Includes copies of the safety certificates for VM600-rack based systems.

Related publications and documentation

See 1.5 Related documentation and 1.6 Applicable standards.

Abbreviations

The following table defines some abbreviations useful to this safety manual and related documentation.

Abbreviation	Meaning
AC	alternating current
ABE04x	VM600 system rack (19" rack with a height of 6U)
AMC8	VM600 analog monitoring card with 8 channels
CMC16	VM600 condition monitoring card with 16 channels
CMS	condition monitoring system
CPU	central processing unit
CPUM	VM600 modular CPU card
CRC	cyclic redundancy check

MEGGITT

Abbreviation	Meaning
CSA	Canadian Standards Association
DC	diagnostic coverage
DC	direct current
EUC	equipment under control
FMEDA	failure modes, effects and diagnostic analysis
HFT	hardware fault tolerance
IEC 61508	IEC standard "Functional safety of electrical/electronic/programmable electronic safety-related systems"
IEC 61511	IEC standard "Functional safety – safety instrumented systems for the process industry sector"
IOC4T	VM600 input/output card (for use with MPC4 cards)
IOC8T	VM600 input/output card (for use with the AMC8 card)
IOC16T	VM600 input/output card (for use with the CMC16 card)
IOCN	VM600 input/output card (for use with the CPUM card)
IRC4	VM600 intelligent relay card (for use with the MPC4 cards and AMC8 card)
ISO 13849-1	ISO standard "Safety of machinery – Safety-related parts of control systems – Part 1: General principles for design"
MOSFET	metal oxide semiconductor field-effect transistor
MPC4	VM600 machinery protection card
MPC4SIL	VM600 machinery protection card with no VME bus interface
MPS	machinery protection system
MPSx	See VM600 MPSx
MTTFd	mean time to fail dangerous
MTTR	mean time to repair/restoration
N/A	not applicable, not available
OC	open collector
PFD	probability of failure on demand
PFDavg	average probability of failure on demand
PFH	probability of failure per hour (high-demand system)
PL	performance level
PTC	proof test coverage
PTI	proof test interval
PNR	part number
PLC	programmable logic controller
PSU	power supply unit

Abbreviation	Meaning
RLC16	VM600 relay card
RPM	revolutions per minute
RPS6U	VM600 power supply
SFF	safe failure fraction
SIF	safety instrumented function
SIL	safety integrity level
SIS	safety instrumented system
SRS	safety-related system
SP	safety parameters
SRS	safety-related system
TÜV	A technical inspection agency (from the German – Technischer Überwachungs-Verein)
vibro-meter®	A Meggitt product line
VM	Vibro-Meter SA (Vibro-Meter SA is now Meggitt SA and vibro-meter® is a product line of Meggitt)
VM600	VM600 series of machinery protection systems and condition monitoring systems
VM600 MPSx	VM600 MPS1 and VM600 MPS2 software
VME	Versa Module Eurocard (a computer bus standard)
WEEE	waste electrical and electronic equipment
XIO16T	VM600 extended input/output card (for use with the XMC16 and XMV16)
XMC16	VM600 extended monitoring card for combustion with 16 channels
XMV16	VM600 extended monitoring card for vibration with 16 channels

Terminology

MPC4 cards

The MPC4 machinery protection card is available in different versions, including a standard version, a separate circuits version and a safety (SIL) version. See 1.7 Different versions of the MPC4 card for additional information.

In general, MPC4 is used in this manual to refer to all versions of the card. However, where it is necessary to make a distinction, MPC4 is used to indicate the standard and separate circuits versions of the card and MPC4SIL is used to indicate the safety version.

MEGGITT

Relays

By convention, the normally closed (NC) and normally open (NO) relay terminology refers to the state of the relay contacts when the relay's coil is de-energised. This use of the word "normally" is not directly related to the "normal" operation/state of the machinery being monitored, as explained below.

When the power supply to a device is turned off:

- There is a closed circuit between the normally closed (NC) and common (COM) contacts.
- There is an open circuit between the normally open (NO) and common (COM) contacts.

When the power supply to a device is turned on, the state of the relay contacts depends on whether the relay's coil is energised or de-energised.

When the relay's coil is energised:

- There is an open circuit between the normally closed (NC) and common (COM) contacts.
- There is a closed circuit between the normally open (NO) and common (COM) contacts.

Whether a relay's coil is energised or de-energised depends on how the relay has been configured, for example, as normally de-energised (NDE) or normally energised (NE) and as latched or not latched. It also depends on the control signal that is used to drive the relay. For example, specific alarms (A+, D- and so on) generated by an MPC4 card.

A relay can be configured to be either normally de-energised (NDE) or normally energised (NE).

Normally de-energised (NDE) and normally energised (NE) refer to the relay coil state (that is, the relay switching circuit) when the hardware is powered and the signal driving the relay's control circuit is in a normal (non-alarm) state.

- For relays configured as normally de-energised (NDE), the control input to the relay's coil is off by default so there is a closed circuit between the NC and COM contacts (and an open circuit between the NO and COM contacts) for a normal state.
- For relays configured as normally energised (NE), the control input to the relay's coil is on by default so there is an open circuit between the NC and COM contacts (and a closed circuit between the NO and COM contacts) for a normal state.

NOTE: Relays configured as normally energised (NE) must de-energise to trip. That is:

- The relay is energised when the monitored levels are within their specified tolerances, in order to indicate normal operation.
- The relay is de-energised when the monitored levels are outside their specified tolerances, in order to indicate an alarm.

An advantage of normally energised (NE) relays is that the "de-energise to trip principle" allows problems with hardware to be detected (for example, due to power supply or wiring failures).

See 2.1 VM600 in a safety-related system for addition information.

MEGGITT

Software

VM600 MPSx is proprietary software from the Meggitt vibro-meter[®] product line that can configure and manage VM600 racks containing AMC8 and MPC4 cards:

- VM600 MPS1[©] allows the complete configuration of a VM600 machinery protection system and the display of live data. It is intended to be used for machinery protection applications.
- VM600 MPS2[©] allows the complete configuration of a VM600 machinery protection system and the display of historical or live data. It is intended to be used for machinery protection and/or basic condition monitoring applications.

(VM600 MPS2 includes all of the functionality provided by the VM600 MPS1 software with additional features, such as plots for the visualisation and trending of data.)

VibroSight[®] is proprietary software from the Meggitt vibro-meter[®] product line that can configure and manage VM600 XMx16 cards such as the XMC16, XMV16 and XMVS16, and/or VibroSmart[®] distributed monitoring system (DMS) modules such as the VSI010 and VSV30x.

VM600 IRC4 Configurator is proprietary software from the Meggitt vibro-meter[®] product line that can configure and manage IRC4 cards.

MEGGITT

SAFETY

Symbols and styles used in this manual

The following symbols are used in this manual where appropriate:



The **WARNING** safety symbol

THIS INTRODUCES DIRECTIVES, PROCEDURES OR PRECAUTIONARY MEASURES WHICH MUST BE EXECUTED OR FOLLOWED. FAILURE TO OBEY A WARNING MIGHT RESULT IN INJURY TO THE OPERATOR AND/OR THIRD PARTIES, AND/OR RESULT IN DAMAGE TO EQUIPMENT.



The **CAUTION** safety symbol

This draws the operator's attention to information, directives or procedures which must be executed or followed. Failure to obey a caution can result in damage to equipment.

NOTE: This is an example of the NOTE paragraph style. This draws the operator's attention to complementary information or advice relating to the subject being treated.

Important remarks on safety-related applications



USE OF A VM600 MACHINERY PROTECTION SYSTEM (MPS) IN A SAFETY-RELATED APPLICATION ASSUMES THAT THE INSTRUCTIONS AND RECOMMENDATIONS IN THIS SAFETY MANUAL ARE IMPLEMENTED AS APPROPRIATE BY THE END USER.

FAILURE TO FOLLOW THE INSTRUCTIONS AND IMPLEMENT THE RECOMMENDATIONS IN THIS SAFETY MANUAL MIGHT RESULT IN INJURY TO THE OPERATOR AND/OR THIRD PARTIES, AND/OR RESULT IN DAMAGE TO EQUIPMENT AND WILL INVALIDATE ANY WARRANTY.

MEGGITT

Important remarks on safety



Read this manual carefully and observe the safety instructions before installing and using the equipment described.

By doing this, you will be aware of the potential hazards and be able to work safely, ensuring your own protection and also that of the equipment.

Every effort has been made to include specific safety-related procedures in this manual using the symbols described above. However, operating personnel are expected to follow all generally accepted safety procedures.

All personnel who are liable to operate the equipment described in this manual should be trained in the correct safety procedures.

Meggitt does not accept any liability for injury or material damage caused by failure to obey any safety-related instructions or due to any modification, transformation or repair carried out on the equipment without written permission from Meggitt SA. Any modification, transformation or repair carried out on the equipment without written permission from Meggitt SA will invalidate any warranty.

MEGGITT**TABLE OF CONTENTS**

TITLE PAGE	i
REVISION RECORD SHEET	ii
IMPORTANT NOTICES	vi
PREFACE	vii
SAFETY	xiii
TABLE OF CONTENTS	xv
1 INTRODUCTION	1-1
1.1 Purpose	1-1
1.2 Scope	1-1
1.3 Warning	1-2
1.4 Reference part numbers	1-2
1.5 Related documentation	1-4
1.6 Applicable standards	1-5
1.7 Different versions of the MPC4 card	1-5
1.7.1 Standard version of the MPC4	1-6
1.7.2 Separate circuits version of the MPC4	1-6
1.7.3 Safety version of the MPC4	1-6
1.7.4 Identifying different versions of the MPC4 card	1-7
1.7.5 Permitted rack configurations	1-9
1.8 Avoiding possible conflicts from additional cards	1-10



2 SAFETY ISSUES	2-1
2.1 VM600 in a safety-related system	2-1
2.2 Valid safety configurations	2-1
2.3 Safety inputs and outputs	2-2
2.4 Safety function.	2-3
2.5 ISO 13849-1 performance level	2-4
2.6 Safety time	2-4
2.7 Protection of relay contacts	2-4
2.8 Installation	2-5
2.9 Configuring the system	2-5
2.9.1 Define the levels	2-5
2.9.2 Define the alarm outputs	2-5
2.9.3 Upload the levels and configuration	2-6
2.9.4 Configuration verification.	2-6
2.10 Commissioning	2-7
2.10.1 Guidelines for commissioning	2-7
2.11 Proof test interval and product lifetime	2-7
2.12 Maintenance	2-7
3 END-OF-LIFE PRODUCT DISPOSAL	3-1
4 SERVICE AND SUPPORT	4-1
4.1 Contacting us	4-1
4.2 Technical support	4-1
4.3 Sales and repairs support	4-2
4.4 Customer feedback	4-2
Energy product return procedure	3
Energy product return form	4
MPC4SIL card proof test interval procedure	7
MPC4SIL card proof test interval form	8
Energy customer feedback form	10
A APPENDIX A: SAFETY CERTIFICATES	A-1

1 INTRODUCTION

1.1 Purpose

The purpose of this document is to describe the use of a VM600 machinery protection system (MPS) in a safety-related application (functional safety context) as defined by IEC 61508 and ISO 13849-1.

1.2 Scope

The document applies to VM600 rack-based machinery protection system (MPSs) as outlined below in Figure 1-1 and Table 1-1.

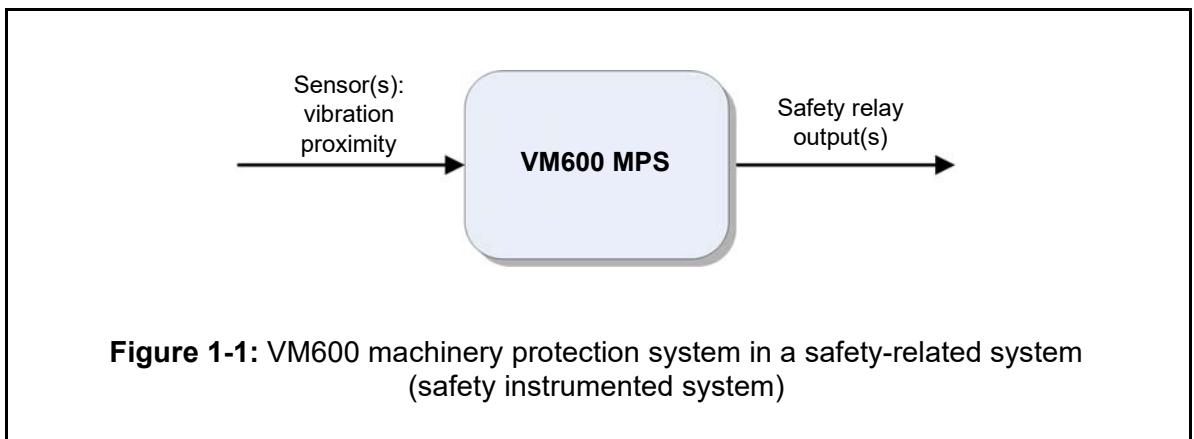

Table 1-1: VM600 machinery protection system components

Part	Description	Mandatory	Comment
ABE04x	Rack	Yes	19" rack
RPS6U	Power supply	Yes	Two PSUs should be used. The PSUs can be AC or DC.
MPC4	Machinery protection card (4+2 channels)	Yes	1 to <i>n</i> cards
IOC4T	Input/output card for the MPC4	Yes	1 per MPC4 card
RLC16	Relay card	No	
VM600 MPSx	Software	Yes	

A VM600 machinery protection system (MPS) can be used as a complete safety-related system (SRS) that performs a safety function or it can be used as an input to an external system that performs a safety function. See 2.1 VM600 in a safety-related system for further information.

INTRODUCTION

Warning

MEGGITT

1.3 Warning

The following symbol introduces directives, procedures or precautionary measures which must be executed or followed.



FAILURE TO OBEY A WARNING MIGHT RESULT IN INJURY TO THE OPERATOR OR THIRD PARTIES AND DAMAGE TO EQUIPMENT.

1.4 Reference part numbers

Table 1-2 lists the reference part numbers that are applicable to safety-system racks using the standard version of the MPC4 card.

Table 1-3 lists the reference part numbers that are applicable to safety-system racks using a safety version of the MPC4 card (MPC4SIL).

For an explanation of the differences between standard and safety versions of the MPC4, see 1.7 Different versions of the MPC4 card.

NOTE: Table 1-2 refers to earlier safety-system racks using a previous version of the standard MPC4 card and should be used for reference only.

Table 1-2: Reference part numbers for VM600 safety-system racks using a standard MPC4 card

Part number (PNR)	Card or product name
204-040-100-012	Standard 19" rack
204-040-100-112	Standard 19" rack, separate circuits version
204-040-100-211	Standard 19" rack, CSA standard
204-042-100-012	Standard 19" rack, Siemens standard
200-582-200-013	RPS6U power supply, 24 V _{DC} version
200-582-300-013	RPS6U power supply, 48 V _{DC} version
200-582-400-011	RPS6U power supply, 72 V _{DC} version
200-582-600-013	RPS6U power supply, 110 V _{DC} version
200-582-500-013	RPS6U power supply, 110/230 V _{AC} version
200-510-071-113	MPC4 machinery protection card (standard version)
200-560-000-113	IOC4T input/output card (for the MPC4)
200-570-000-111	RLC16 relay card
209-500-100-SSS	VM600 MPSx software (used to configure cards)

NOTE: Table 1-3 refers to current safety-system racks using the latest versions of the safety MPC4 card (MPC4SIL) and the standard MPC4 card.

Table 1-3: Reference part numbers for VM600 safety-system racks using a safety MPC4 card (MPC4SIL)

Part number (PNR)	Card or product name
204-040-100-0Hh	Standard 19" rack
204-040-100-1Hh	Standard 19" rack, separate circuits version
200-582-xxx-HHh	RPS6U power supply, 24 V _{DC} , 48 V _{DC} , 72 V _{DC} , 110 V _{DC} or 110/230 V _{AC} version
200-510-077-313 <i>or</i> 200-510-077-312 <i>or</i> 200-510-071-311	MPC4SIL machinery protection card (safety version – with no VME bus interface)
200-510-0SS-1Hh	MPC4 machinery protection card (standard version)
200-560-000-114 <i>or</i> 200-560-000-113	IOC4T input/output card (for the MPC4)
200-570-000-112 <i>or</i> 200-570-000-111	RLC16 relay card
601-001-CCC-HHh	IRC4 intelligent relay card
200-550-SSs-HHh	AMC8 analog monitoring card
200-580-000-HHh	IOC8T input/output card (for the AMC8)
200-530-SSs-HHh	CMC16 condition monitoring card
200-565-000-HHh	IOC16T input/output card (for the CMC16)
200-595-SSs-HHh	CPUM modular CPU card
200-566-000-HHh	IOCN input/output card (for the CPUM)
600-002-VVV-VVV	XMC16 extended monitoring card for combustion
600-003-VVV-VVV	XMV16 extended monitoring card for vibration
620-002-000-HHH	XIO16T extended input/output card (for the XMC16 and XMV16)

INTRODUCTION

Related documentation

MEGGITT

1.5 Related documentation

This safety manual is limited to the information and actions that are required to ensure compliance with the relevant safety certifications and standards.

Table 1-4 lists other Meggitt vibro-meter[®] documentation, such as data sheets and manuals, that must be referred to for information outside the scope of this safety manual.

Table 1-4: Related documentation

Document name	Document reference
<i>VM600 system rack (ABE04x) data sheet</i>	268-001
<i>RPS6U rack power supply data sheet</i>	268-011
<i>MPC4 machinery protection card data sheet</i>	268-021
<i>IOC4T input/output card for MPC4 data sheet</i>	268-071
<i>RLC16 relay card data sheet</i>	268-081
<i>AMC8 and IOC8T analog monitoring card and input/output card data sheet</i>	268-041
<i>CPUM and IOCN modular CPU card and input/output card data sheet</i>	268-031
<i>IRC4 Intelligent relay card data sheet</i>	268-085
<i>XMx16 and XIO16T extended condition monitoring cards data sheet</i>	660-020-010-20xA
<i>VM600 machinery protection system (standard version) hardware manual</i>	MAMPS-HW/E
<i>VM600 MPS1 configuration software for machinery protection systems software manual</i>	MAMPS1-SW/E
<i>VM600 MPS2 configuration software for machinery protection systems software manual</i>	MAMPS2-SW/E

NOTE: Ensure that the latest version of related documentation is being used by obtaining the documents from the Meggitt vibro-meter[®] Energy website at www.meggittsensing.com/energy or by contacting your local Meggitt representative.

1.6 Applicable standards

Table 1-5 : Applicable standards

Document name	Document reference
<i>IEC 61508: Functional safety of electrical/electronic/programmable electronic safety-related systems</i>	Edition 2 (2010)
<i>IEC 61511: Functional safety – safety instrumented systems for the process industry sector</i>	Edition 1 (2003/2004)
<i>ISO 13849-1: Safety of machinery – Safety-related parts of control systems – Part 1</i>	Edition 3 (2015)
<i>ISO 13849-2: Safety of machinery – Safety-related parts of control systems – Part 2</i>	Edition 2 (2012)

1.7 Different versions of the MPC4 card

The MPC4 machinery protection card is available in different versions, including:

- Standard version – see 1.7.1 Standard version of the MPC4.
- Separate circuits version – see 1.7.2 Separate circuits version of the MPC4.
- Safety version (MPC4SIL) – see 1.7.3 Safety version of the MPC4.

NOTE: Both the standard and the safety versions of the MPC4 card are certified to IEC 61508 and ISO 13849. The safety version (MPC4SIL) was developed to permit a wider range of installation options.

The original IEC 61508 and ISO 13849 certification process targeted a VM600 rack for safety-related system applications with a limited range of cards, that is, standard MPC4/IOC4T card pairs and RLC16 relay cards (see Table 1-2).

Then Meggitt SA decided to safety certify another system with additional functionality, such as monitoring (see Table 1-3). To safety certify such a VM600 rack, it was necessary to ensure that there is no possibility of the configuration being inadvertently modified. The safety version (MPC4SIL) of the MPC4 card overcomes this potential configuration issue by not implementing a VME bus interface, so data corruption via the VM600 rack backplane's VME bus is impossible.

NOTE: Only the standard version and the safety version of the MPC4 are certified by TÜV® NORD for use in safety-related systems. The other versions of the MPC4 card which exist are not certified for use in safety-related systems.

INTRODUCTION

Different versions of the MPC4 card

MEGGITT

1.7.1 Standard version of the MPC4

The standard MPC4 card is the original version, intended for systems using a VM600 rack with a limited range of cards, that is, standard MPC4/IOC4T card pairs and RLC16 relay cards (see Table 1-2).

The standard MPC4 has a VME-compatible slave interface and is software configurable via RS-232 (on the front panel of the MPC4 card) or via VME for a networked VM600 rack. It also supports all processing modes (refer to Table 7-1 in section 7.1 Different versions of the MPC4 card of the *VM600 machinery protection system (standard version) hardware manual*).

1.7.2 Separate circuits version of the MPC4

The separate circuits MPC4 card is intended for systems using a separate circuits version of the VM600 rack. The separate circuits MPC4 was developed in accordance with the CEI/IEC 60255-5 standard: "Insulation coordination for measuring relays and protection equipment – Requirements and tests" and has slightly different circuitry (refer to section 9.10 Grounding options in the *VM600 machinery protection system (standard version) hardware manual*).

Like the standard MPC4, the separate circuits MPC4 has a VME-compatible slave interface and is software configurable via RS-232 (on the front panel of the MPC4 card) or via VME for a networked VM600 rack. It also supports all processing modes (refer to Table 7-1 in section 7.1 Different versions of the MPC4 card of the *VM600 machinery protection system (standard version) hardware manual*).

1.7.3 Safety version of the MPC4

The safety (SIL) version of the MPC4 card, that is the MPC4SIL, was developed to permit a wider range of installation options with a single VM600 rack, for example, condition monitoring in addition to machinery protection (see Table 1-3). To safety certify these systems, it was necessary to ensure that the safety MPC4 is isolated from the other cards in a VM600 rack, so that there is no possibility of its configuration being inadvertently modified.

As the safety MPC4 (MPC4SIL) does not have a VME bus interface, corruption of its configuration is impossible as it is only software configurable via RS-232 (on the front panel of the MPC4 card). Therefore, it is now possible to define a single VM600 rack configuration containing condition monitoring cards (such as the CMC16 and XMx16) and relay cards (such as the IRC4 and RLC16) in addition to safety-related machinery protection in the form of safety MPC4 cards.

However, the MPC4SIL card does not support all of the processing modes supported by the standard and the separate circuits versions of the MPC4 cards (refer to Table 7-1 in section 7.1 Different versions of the MPC4 card of the *VM600 machinery protection system (standard version) hardware manual*).

For example, the MPC4 SIL card does not support the Narrow Band (Tracking) Vibration and S_{max} processing functions, speed/phase reference (tachometer) processing, or the danger bypass (DB) and trip multiply (TM) functions.

For an MPC4SIL card, the valid MPC4 card processing modes (signal processing functions) for safety-related systems are summarised in Table 2-1.

1.7.4 Identifying different versions of the MPC4 card

The different versions of the MPC4 card can be visually identified from their front panels, as the lower handle on the front panel is different.

- For the standard and separate circuits versions of the MPC4 card, the label on the lower handle of the front panel displays the text “MPC 4” against a blue background, as shown in Figure 1-2 (a).
- For the safety (SIL) version of the MPC4 card, the label on the lower handle of the front panel displays the circular TÜV NORD logo and text “MPC 4” against an orange background, as shown in Figure 1-2 (b).

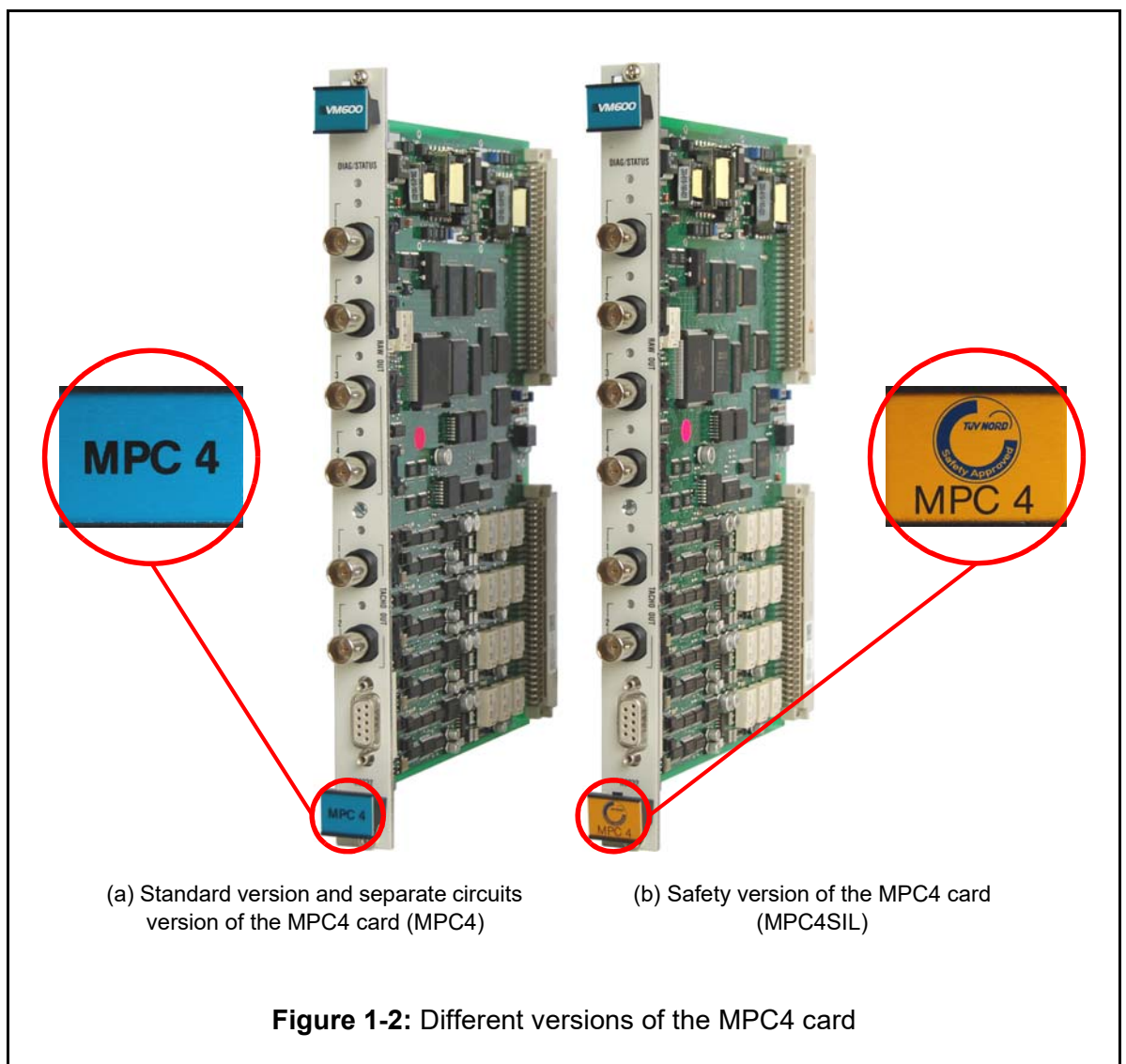

INTRODUCTION

Different versions of the MPC4 card

MEGGITT

The ordering number (PNR) for a MPC4 card is given in the format 200-510-SSS-xHh.

In this PNR, **x** represents the version of the MPC4 card as follows:

- 1 indicates the standard version of the card.
- 2 indicates the separate circuits version of the card.
- 3 indicates the safety (SIL) version of the card.

NOTE: Refer to the *MPC4 machinery protection card data sheet* for further information (see 1.5 Related documentation).

In addition, in the VM600 MPSx software (version 2.6.x or later), two different names are used to identify and work with the different versions of MPC4 card:

- MPC4 is used to refer to the standard and separate circuits versions of the MPC4 card.
- MPC4SIL is used to refer to safety version of the MPC4 card.

NOTE: Refer to the *VM600 MPS1 configuration software for machinery protection systems software manual* for further information (see 1.5 Related documentation).

1.7.5 Permitted rack configurations

The standard MPC4 card (MPC4, PNR 200-510-071-113) is safety certified. However, there are certain restrictions to the optional card configurations that are allowed with a standard MPC4 card in a VM600 rack.

The safety MPC4 card (MPC4SIL, PNR 200-510-077-313, PNR 200-510-077-312 and PNR 200-510-071-311) can be installed in a VM600 rack that also contains additional cards.

The permitted VM600-rack based monitoring and protection system options are summarised in Table 1-6.

Table 1-6: Summary of permitted VM600-rack based monitoring and protection system options

Processing and respective input/output cards	Description	Allowed with standard MPC4 (PNR 200-510-071-113)	Allowed with safety MPC4 (PNR 200-510-077-313, PNR 200-510-077-312 and PNR 200-510-071-311)
RPS6U	Power supply	2 required	2 required
RLC16	Relay card	Yes	Yes
IRC4	Intelligent relay card	No	Yes
CPUM and IOCN	Modular CPU card pair	No	Yes
AMC8 and IOC8T	Analog monitoring card pair	No	Yes
CMC16 and IOC16T	Condition monitoring card pair	No	Yes
XMC16 and XIO16T	Extended monitoring card pair for combustion	No	Yes
XMV16 and XIO16T	Extended monitoring card pair for vibration	No	Yes

NOTE: Refer to the corresponding data sheets for further information on card functionality and options.

INTRODUCTION

Avoiding possible conflicts from additional cards

MEGGITT

1.8 Avoiding possible conflicts from additional cards



INTERFERENCE TO A SAFETY FUNCTION MIGHT OCCUR IF ADDITIONAL VM600 CARDS ARE INSTALLED IN A RACK WITH AN IMPROPER CONFIGURATION. CERTAIN FAILURES, WHILST UNLIKELY, MIGHT ALSO COMPROMISE A SAFETY FUNCTION. THESE CAN BE AVOIDED BY CONFIGURATION RESTRICTIONS AND RULES.

It is essential that the complete system configuration is reviewed by the operator to identify any conflicts. These conflicts are in two categories:

- Raw Bus issues

The Raw Bus is a bus on the VM600 rack's backplane that is normally used to pass sensor signals to other VM600 cards. It contains 64 parallel bus lines, arranged as 32 differential line pairs. It is common to all slots in the rack.

- OC Bus issues

The OC Bus is a bus on the VM600 rack's backplane that is normally used to drive RLC16 relay cards. It consists of 96 open collector lines, arranged as six bus partitions of 16 lines. Each bus partition is separate and is associated with only three slots in the rack.

The configuration rules needed for safety-related systems are:

- If any safety-relevant signal is to be shared between VM600 cards in the same rack (upstream or downstream), then this function must be performed by external cabling.

NOTE: The buffered (raw) outputs from the MPC4 card and the IOC4T card must not be used to feed safety-relevant signals to other safety-relevant equipment, including other VM600 cards.

However, the buffered (raw) outputs from the MPC4 card and the IOC4T card can be used to feed these signals to non-safety-relevant equipment and systems, such as a data recorder or other VM600 cards not being used for safety.

Rack-internal signal transfer via Raw Bus lines (not buffered) must not be used for safety-relevant channels but can be used for non-safety-relevant channels.

NOTE: The Raw Bus must not be used to share safety-relevant signals between VM600 cards.

- The use of the Raw Bus to drive a safety relay is forbidden¹.
- If AMC8 and IOC8T, XMC16/XMV16 and XIO16T, or IRC4 cards are to be used, then they must be placed in a rack slot that is not associated with an OC Bus partition used by a safety function²³.

1. The use of the Raw Bus for relay drive is a secondary function that is described in section 3.4.4 The Raw Bus of the *VM600 machinery protection system (standard version) hardware manual*.

2. This only applies if an RLC16 card is used for a safety function.

3. Refer to section 3.4.3 The Open Collector Bus of the *VM600 machinery protection system (standard version) hardware manual* for details of the OC Bus and the arrangement of the separate channels by card slot.

Further detail is given in Table 1-7 and Table 1-8 but reference must be made to the associated hardware and/or software manuals in order to obtain complete instructions (see 1.5 Related documentation).

NOTE: If you are in any doubt as to the validity of a particular configuration then you should contact Meggitt customer support for assistance (see 4.1 Contacting us).

The checks summarised in Table 1-7 apply only to racks using an RLC16 relay card as part of a safety function.

Table 1-7: OC Bus checks for safety-related systems that contain a RLC16 card

Rack contains	Verification step	Configuration aid
Single MPC4/IOC4T card pair	No additional checks are required	
Additional MPC4/IOC4T card pairs	Check the configuration for conflicts	VM600 MPSx© software
Additional AMC8/IOC8T card pairs	Place in a different OC Bus partition ^{See note 1}	VM600 MPSx© software
IRC4 card	Place in a different OC Bus partition ^{See note 1}	IRC4 Configurator software
XMx16/XIO16T card pairs	Place in a different OC Bus partition ^{See note 1}	VibroSight® software

Notes

1. The split of the OC Bus into six (6) discrete sections is described in section 3.4.3 The Open Collector Bus of the VM600 machinery protection system (standard version) hardware manual.

The checks summarised in Table 1-8 need only to be made if a signal from a sensor that is locally attached to the safety-relevant IOC4T is routed using the Raw Bus to a separate VM600 card, such as an XMV16 vibration monitoring card. The measures for the XIO16T are needed to cover the unlikely event of a failure of the MOSFET switch matrix that is used by this card.

Other cards use a physical jumper matrix only to racks using an RLC16 relay card as part of a safety function.

INTRODUCTION

Avoiding possible conflicts from additional cards

MEGGITT**Table 1-8:** Raw Bus checks for safety-related systems that share a non-safety signal with other VM600 cards

Rack contains	Verification step / requirement	Configuration aid
Single MPC4/IOC4T card pair	No additional checks are required	
Additional MPC4/IOC4T card pairs	Check the configuration for conflicts	VM600 MPSx© software
Additional AMC8/IOC8T card pairs	Check for double utilisation	VM600 MPSx© software
CMC16/IOC16T card pairs	No additional checks are required	
IRC4 ^{See note 1}	Verify configuration	
XMx16/XIO16T card pairs	Verify configuration	VibroSight® software

Notes

1. The IRC4 intelligent relay card is not used for a safety function itself.

2 SAFETY ISSUES

2.1 VM600 in a safety-related system



WHEN A VM600 IS PART OF A SAFETY-RELATED SYSTEM (SRS), CERTAIN CONFIGURATION RESTRICTIONS MUST BE APPLIED.

NOTE: Alarms can be configured as either latching or as not latching. Relays can be configured as either normally energised (NE), that is, de-energised to trip) or as normally de-energised (NDE), that is, energised to trip.

NOTE: VM600 safety relays corresponding to alarms are refreshed every 100 ms. See also 2.6 Safety time.

In particular:

- The alarms and relays must be configured depending on the role of the VM600 in the safety loop.
 - If a safety function is performed by a VM600-rack based system only, any safety relay corresponding to an alarm must be configured as latching and normally energised (de-energised to trip).
 - If a safety function is performed by an external system using an alarm detected by a VM600-rack based system as an input, the relay corresponding to this alarm may not be configured as latching.

However, an analysis must be carried out at the safety-related system level to ensure that no alarm can be missed or to identify all possible impacts and acceptability of residual risks in case of a missed alarm.
- If a safety function uses a VM600-rack based system alarm that is configured as latching, the use of an alarm delay time is not allowed.
- The use of the VM function danger bypass (DB) is not allowed.
- The use of the VM function trip multiply (TM) is not allowed.
- The use of the VM function channel inhibit is not allowed.

NOTE: The safety version of the MPC4 card (MPC4SIL) does not support the channel inhibit function.

2.2 Valid safety configurations

The VM600 machinery protection system (MPS) is highly configurable. The different configuration options are described in more detail in the *VM600 machinery protection system (standard version) hardware manual* (see 1.5 Related documentation).

The MPC4 card supports many different processing modes and applications that allow a VM600 rack to be configured to protect rotating machines in a safety-related system.

The valid MPC4 card processing modes (signal processing functions) for safety-related systems are summarised in Table 2-1.

SAFETY ISSUES

Safety inputs and outputs



Table 2-1: Valid MPC4 card processing modes for safety-related systems

Processing mode	Reference in VM600 MPS hardware manual
(BBAB) Broad-band absolute bearing vibration	Section 7.2
(RS) Shaft relative vibration with gap monitoring	Section 7.4
(AS) Shaft absolute vibration	Section 7.5
(PS) Position measurement	Section 7.6
(DMF) Dual mathematical function	Section 7.17

Refer to the *VM600 machinery protection system (standard version) hardware manual* for a complete list of all processing modes supported by the MPC4 (see 1.5 Related documentation).

2.3 Safety inputs and outputs

Table 2-2: Overview of valid safety inputs and outputs

Signal	Comments	Reference in VM600 MPS hardware manual
MPC4 channel 1 to channel 4 (inputs)	Ensure cabling follows the guidelines	Table 9-1 (part 1 of 3)
MPC4 relay contacts (outputs)		Table 9-1 (part 2 of 3)
RLC16 relay contacts (outputs)		Figure 11-1

NOTE: Speed/phase reference (tachometer) processing can be performed but the processing results must not be used for any safety-relevant functionality, as the speed/phase reference inputs are not safety inputs.

NOTE: The speed/phase reference (tachometer) buffered (TTL) outputs from the MPC4 card and the VM600 rack’s Tacho Bus must not be used to feed safety-relevant signals to other safety-relevant equipment, including other VM600 cards, as these are not safety outputs.

NOTE: The buffered (raw) outputs from the MPC4 card and the IOC4T card must not be used to feed safety-relevant signals to other safety-relevant equipment, including other VM600 cards, as these are not safety outputs.



2.4 Safety function

With reference to IEC 61508, the safety function for a VM600-rack based system is defined in Table 2-3.

Table 2-3: Definition of the safety function for a VM600 MPS

SF number	Description	Safe state	Required safety parameters
SF1	If an input value (or values) exceed(s) a predefined limit, then a trip activation signal is made.	De-energise to trip (open relay contact). That is, the EUC and the VM600 interpret a de-energised state as a safe state.	See Table 2-4

For the required safety function SF1, the safety parameters (SP) listed in Table 2-4 are required in accordance with IEC 61508.

Table 2-4: Safety parameters

SP number	Safety parameter	Requirement	Comment			
SP1	Safety integrity level	SIL 1				
SP2	Operational mode	Low demand mode				
SP3a	Component type sensor	Type B				
	Component type logic (measuring logic)	Type B				
	Component type actuator (relay)	Type A				
SP4	Hardware fault tolerance (HFT)	0	Single channel architecture of an already existing proven-in-use system should be used for SIL 1 application without any changes			
SP5	Average probability of failure on demand (PFDavg)	$\geq 10^{-2}$ to 10^{-1}	PFDavg by proof test years FMEDA			
			PT=0.5a	PT=1a	PT=2a	PT=5a
			2.81e-3	5.60e-3	1.12e-2	2.79e-2
SP6	Safe failure fraction (SFF) for Type A subsystem	< 60% for SIL 1 and HFT 0				
	Safe failure fraction (SFF) for Type B subsystem	60% to < 90% for SIL 1 and HFT 0				

SAFETY ISSUES

ISO 13849-1 performance level



In practice, the output relay or relays are normally an ‘input’ to a safety-related PLC that takes this input together with other safety-related signals.

2.5 ISO 13849-1 performance level

Table 2-5 shows the breakdown of performance level (PL) by diagnostic coverage and mean time to dangerous failure (MTTFd).

Table 2-5: Determination of the performance level according to DIN EN ISO 13849-1

DC / MTTFd	Without	Without	Low	Medium	Low	Medium	High
Low	a	Not covered	a	b	b	c	Not covered
Medium	b	Not covered	b	c	c	d	Not covered
High	Not covered	c	c	d	d	d	e

Table 2-6 shows the calculated results for the VM600 MPS.

Table 2-6: ISO 13849 performance level achieved

Component	MTTFd (years)	MTTFd Category	Postulated DC for PL c	DC according to FMEDA	PL
VM600 MPS	118	High	< 60 %	35.64 %	c

2.6 Safety time

After the defined safety level threshold has been exceeded, a VM600-rack based system will open the associated safety relay within 100 ms.

2.7 Protection of relay contacts



IN A SAFETY-RELATED SYSTEM IT IS IMPORTANT TO PROTECT AGAINST A RELAY CONTACT BECOMING WELDED DUE TO EXCESSIVE CURRENT BEING INADVERTENTLY PASSED. THEREFORE, THE OUTPUTS MUST BE PROTECTED BY A 5A (T) FUSE.

NOTE: A type T fuse is a “timed” or slow-blow fuse, designed to allow a current which is above the rated value of the fuse to flow for a short period of time without the fuse blowing.

2.8 Installation

A VM600-rack based system must be installed following the procedures described in the *VM600 machinery protection system (standard version) hardware manual* (see 1.5 Related documentation).

Environmental restrictions are described in Appendix A of the hardware manual.

2.9 Configuring the system



IT IS IMPORTANT THAT THE LEVELS (VIBRATION AND SO ON) ARE ADJUSTED TO SUIT THE SYSTEM UNDER PROTECTION AND THAT A MANUAL VERIFICATION IS MADE OF THE PARAMETERS THAT ARE UPLOADED TO A VM600-RACK BASED SYSTEM (MPC4 CARD).

NOTE: The procedures described should only be performed by competent and authorised personnel following the plant specific guidelines in force at the installation site.

2.9.1 Define the levels

The choice of alarm levels must be made in consultation with the site manager. It is the end user's responsibility to ensure that the alarm levels are appropriate for the particular system being protected.

The levels are defined using either the VM600 MPS1 software (supplied) or the VM600 MPS2 software (optional). Refer to the appropriate documentation for complete information.

NOTE: Refer to a *VM600 MPSx configuration software for machinery protection systems software manual* for further information (see 1.5 Related documentation).

2.9.2 Define the alarm outputs

Any relay on the MPC4 or RLC16 cards can be configured to provide the safety function. As previously noted in 2.1 VM600 in a safety-related system, for a safety relay corresponding to an alarm, the alarms and relays must be configured depending on the role of the VM600 in the safety loop.

- If a safety function is performed by a VM600-rack based system only, any safety relay corresponding to an alarm must be configured as latching and normally energised (de-energised to trip).
- If a safety function is performed by an external system using an alarm detected by a VM600-rack based system as an input, the relay corresponding to this alarm may not be configured as latching.

However, an analysis must be carried out at the safety-related system level to ensure that no alarm can be missed or to identify all possible impacts and acceptability of residual risks in case of a missed alarm.

- If a safety function uses a VM600-rack based system alarm that is configured as latching, the use of an alarm delay time is not allowed. That is, the alarm delay time (**Delay**) for the alarm must be configured as zero (**0.0**).

SAFETY ISSUES

Configuring the system

MEGGITT

2.9.3 Upload the levels and configuration

Once the system parameters have been correctly defined using the VM600 MPSx software, the configuration for each MPC4 card must be uploaded to the card. This procedure is described in the *VM600 MPS1 configuration software for machinery protection systems software manual* (see 1.5 Related documentation).

2.9.4 Configuration verification

Whilst the actual upload of data is controlled by CRC verification and other techniques, a manual verification of this upload is required in order to fulfill the IEC 61508 requirements. The verification is made by downloading the configuration from the MPC4 card to the computer and comparing the data received with the original data uploaded to the card.

To verify an upload:

- 1- Select the appropriate MPC4 card with the VM600 MPSx software (as used in 2.9.3 Upload the levels and configuration).
- 2- Use the **Dump to File** option to save the configuration as *pc_card_1.csv*.
- 3- Define a dummy rack using a Tag name *from_sys_1*.
- 4- Select this rack, connect to the MPC4 card concerned and read its configuration back to the computer.
- 5- Dump this file as *sys_card_1.csv*.
- 6- Use the MS-DOS `fc` (file compare) command to compare the two files, as shown in Figure 2-1.

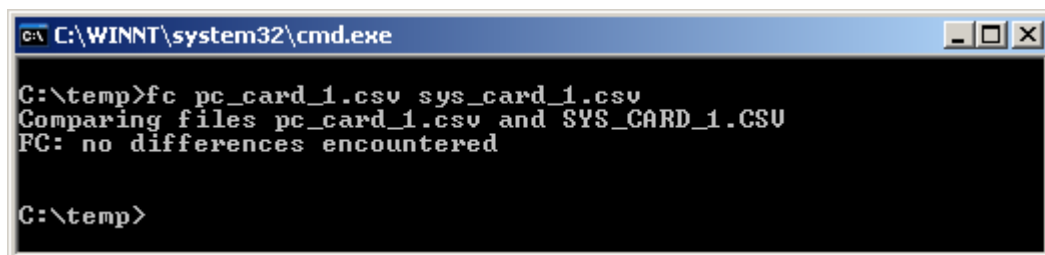

```
C:\WINNT\system32\cmd.exe
C:\temp>fc pc_card_1.csv sys_card_1.csv
Comparing files pc_card_1.csv and SYS_CARD_1.CSV
FC: no differences encountered
C:\temp>
```

Figure 2-1 : MS-DOS `fc` command screen shot

NOTE: If any differences exist, then the upload must be repeated and the comparison repeated.

2.10 Commissioning



A VM600-RACK BASED SYSTEM SHOULD BE COMMISSIONED AS AN INTEGRAL PART OF THE OVERALL SAFETY-RELATED SYSTEM COMMISSIONING.

NOTE: Installation and commissioning should only be performed by competent and authorised personnel following the plant specific guidelines in force at the installation.

2.10.1 Guidelines for commissioning

Installing a VM600-rack based system is fully described in section 8 of the *VM600 machinery protection system (standard version) hardware manual* (see 1.5 Related documentation).

2.11 Proof test interval and product lifetime

A safety MPC4 (MPC4SIL) card has a proof test interval of 5 years. That is, as a SIL-certified product operating in the low demand mode in a safety instrumented system (safety-related system), it has a product lifetime of 5 years.

At the proof test interval, or earlier, an MPC4SIL card used in a SIS must be either proof tested or replaced in order to ensure that the card is working and performing as expected (with no faults). To ensure the highest standards of reliability and risk reduction, Meggitt SA has elected to replace an MPC4SIL card used in a safety-related system at the proof test interval (end of product lifetime).

Every **5 years**, an MPC4SIL card used in a safety an SIS must be returned to Meggitt SA for replacement. Contact Meggitt customer support for further information (see 4.1 Contacting us).

NOTE: When a safety MPC4 (MPC4SIL) card is returned for replacement at the proof test interval, it should be accompanied by a completed MPC4SIL card proof test interval form, included on page 4-8.

2.12 Maintenance

System maintenance should be performed following the guidelines in the *VM600 machinery protection system (standard version) hardware manual* (see 1.5 Related documentation).

NOTE: Any attempt by unauthorised personnel to modify or repair equipment still under guarantee will invalidate the warranty.

See 4.1 Contacting us for the contact details relevant to repairing defective hardware.



IF THE VM600 MPS SYSTEM IS UNDER MAINTENANCE OR REPAIR, THEN THE ATTACHED SYSTEM AND EQUIPMENT MAY NO LONGER BE PROTECTED. THEREFORE, SUCH PROCEDURES SHOULD ONLY BE UNDERTAKEN BY AUTHORISED PERSONNEL RESPECTING THE OVERALL PLANT OPERATION PROCEDURES.

See also 2.11 Proof test interval and product lifetime.

SAFETY ISSUES

Maintenance

MEGGITT

THIS PAGE INTENTIONALLY LEFT BLANK

3 END-OF-LIFE PRODUCT DISPOSAL

A VM600-rack based system is an electrical/electronic product, therefore, it must be disposed of in an acceptable manner at the end of its useful life. This is important in order to reduce pollution and improve resource efficiency.

NOTE: For environmental and economic reasons, end-of-life electrical and electronic equipment must be collected and treated separately from other waste: it must not go into landfill (or tip, dump, rubbish dump, garbage dump or dumping ground).

In Europe (the European Union), end-of-life electrical/electronic products are classed as waste electrical and electronic equipment (WEEE), and are subject to the requirements of the European Union (EU) directive 2012/19/EU on waste electrical and electronic equipment (commonly referred to as the WEEE directive).

According to the WEEE regulations, all waste electrical and electronic equipment should be collected separately and then treated and disposed of in accordance with the best available and environmentally friendly techniques. This is because electronic waste (or e-waste) may contain substances harmful to the environment and/or to human health. In addition, electronic waste is also a valuable source of raw materials that can contribute to a circular economy.

The WEEE symbol (a “crossed-out wheeled bin”) is used on product labelling to indicate equipment that must be properly treated and disposed of at the end of its life (see Figure 3-1).

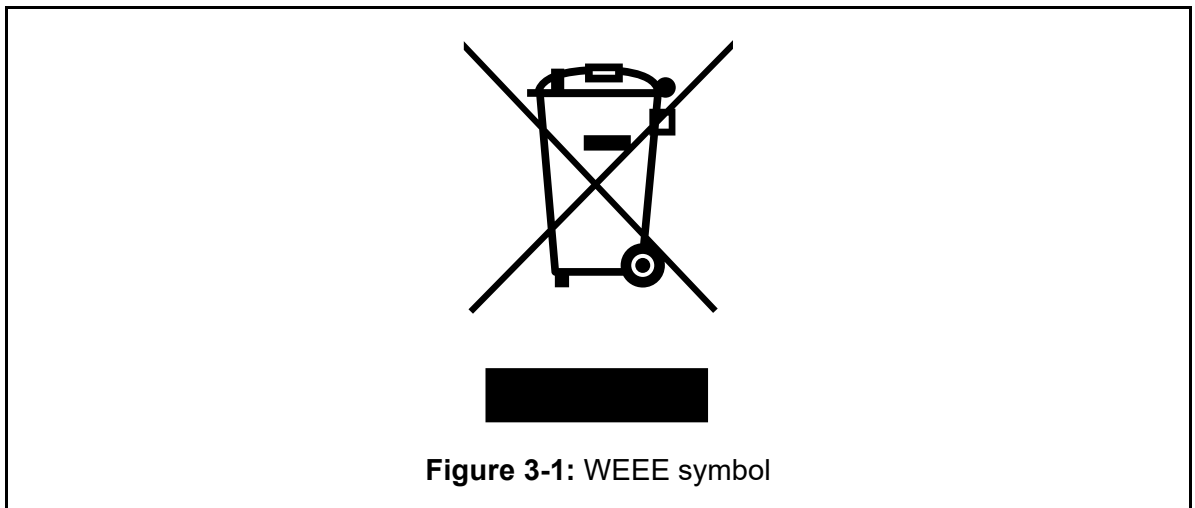

Although a number of non-EU countries have enacted WEEE regulations, different end-of-life product disposal laws and regulations apply in other countries and regions of the world. Accordingly, consult your local authorities to obtain the information and guidance relevant to your country and region.

NOTE: At the end of its useful life, a VM600-rack based system must be disposed of in an environmentally friendly manner.
In European Union Member States, the WEEE directive is applicable.
In other countries and regions of the world, different laws and regulations may be applicable, so consult your local authorities.

END-OF-LIFE PRODUCT DISPOSAL

MEGGITT

For additional end-of-life product disposal information and guidance, contact your local Meggitt representative. Alternatively, contact our main office:

Environment, health and safety department

Meggitt SA

Route de Moncor 4

Case postale

1701 Fribourg

Switzerland

Telephone: +41 26 407 11 11

Email: ehs@ch.meggitt.com

Website: www.meggittsensing.com/energy

4 SERVICE AND SUPPORT

4.1 Contacting us

Meggitt's worldwide customer support network offers a range of support, including 4.2 Technical support and 4.3 Sales and repairs support. For customer support, contact your local Meggitt representative. Alternatively, contact our main office:

Customer support department

Meggitt SA

Route de Moncor 4

Case postale

1701 Fribourg

Switzerland

Telephone: +41 26 407 11 11

Email: energysupport@ch.meggitt.com

Website: www.meggittsensing.com/energy

4.2 Technical support

Meggitt's technical support team provide both pre-sales and post-sales technical support, including:

- 1- General advice
- 2- Technical advice
- 3- Troubleshooting
- 4- Site visits.

NOTE: For further information, contact your local Meggitt representative or Meggitt SA (see 4.1 Contacting us).

SERVICE AND SUPPORT

Sales and repairs support

MEGGITT

4.3 Sales and repairs support

Meggitt's sales team provide both pre-sales and post-sales support, including advice on:

- 1- New products
- 2- Spare parts
- 3- Repairs
- 4- Safety MPC4 (MPC4SIL) card replacement at the proof test interval (every 5 years).

NOTE: If a product has to be returned for repairs, then it should be accompanied by a completed Energy product return form, included on page 4-4.

NOTE: When a safety MPC4 (MPC4SIL) card is returned for replacement at the proof test interval (see 2.11 Proof test interval and product lifetime), it should be accompanied by a completed MPC4SIL card proof test interval form, included on page 4-8.

4.4 Customer feedback

As part of our continuing commitment to improving customer service, we warmly welcome your opinions. To provide feedback, complete the Energy customer feedback form on page 4-10 and return it to Meggitt SA's main office (see 4.1 Contacting us).

REPAIRS AND RETURNS

Energy product return procedure

If a Meggitt vibro-meter® Energy product needs to be returned to Meggitt Switzerland, please use the online product return procedure on the Meggitt vibro-meter® Energy website at: www.meggittsensing.com/energy/service-and-support/repair

As described on the website, the product return procedure is as follows:

- 1- Complete and submit online the **Energy product return form** that is available on the website (note: * indicates a required field).

For each Energy product to be returned, a separate Energy product return form must be completed and submitted online.

When an Energy product return form is submitted online, an acknowledgement email including an Energy product return reference number, will be sent by return to confirm that the form was received by Meggitt SA.

Please use the Energy product return reference number in all future communications regarding your product return.

- 2- Complete and include an end-user certificate.

For each Energy product to be returned, an associated end-user certificate is also required.

The single-use end-user certificate is recommended for smaller organisations that handle few products and the annual end-user certificate is recommended for larger organisations that handle many products.

Either end-user certificate can be used to cover multiple products.

NOTE: Visit the website or contact our Customer support department (see 4.1 Contacting us) to obtain the appropriate end-user certificate form.

- 3- Send the Energy product together with printed copies of the acknowledgement email (or emails) and the end-user certificate (or certificates) to Meggitt SA at:

Repairs department, Meggitt SA, Route de Moncor 4, Case postale, 1701 Fribourg, Switzerland.

A separate acknowledgement email (printed copy) is required for each product to be returned, although a single end-user certificate (printed copy) can be used for multiple products.

- 4- In addition, a purchase order (PO) with a value of CHF 0.00 must also be sent to Meggitt SA, in order to support the initial problem diagnosis.

NOTE: The **Energy product return form** reproduced below is included to support the gathering of information required for completion and submission online.

SERVICE AND SUPPORT

Customer feedback

MEGGITT

Energy product return form

Contact information

First name:*

Last name:*

Job title:

Company:*

Address:*

Country:*

Email:*

Telephone:*

Fax:

Product information

Product type:*

Part number (PNR):*

Serial number (SER):

Note: Enter "Unknown" if the serial number (SER) is not known.

Ex product:

 Yes No

SIL product:*

 Yes No

Meggitt SA purchase order number:

Date of purchase (dd.mm.yyyy):

Product under warranty:

 Yes No Don't know

Site where installed:

End user:

MEGGITT

SERVICE AND SUPPORT

Customer feedback

Return information

Reason for return:*

- Repair
- Out-of-box failure

If the reason for return is "Repair", please answer the following questions:*

Type of failure:

- Continuous
- Intermittent
- Temperature dependent

How long was the operating time before failure?

Description of failure:

Please provide a detailed description in order to help with problem diagnosis.

If the reason for return is "Out-of-box failure", please answer the following questions:*

Type of out-of-box failure:

- Product damaged
- Incorrect product configuration
- Incorrect product delivered
- Problem with documentation / labelling
- Product dead-on-arrival

Additional information:

Please provide as much information as possible in order to help with problem diagnosis.

SERVICE AND SUPPORT

Customer feedback

MEGGITT

Ex product information – additional information required for Ex products only

Is the product installed in a hazardous area (potentially explosive atmosphere)?:

- Yes
- No

If the product is installed in a hazardous area, please answer the following questions:

How long was the operating time before failure?:

Additional information:

SIL product information – additional information required for SIL products only*Note: For SIL products used in functional safety contexts/systems, this **SIL product information** section must be completed.

Is the product installed in a safety-related system?:*

- Yes
- No

If the product is installed in a safety-related system, please answer the following questions:*

Did the system fail** in a safe mode?:* (That is, the safety relay operated but the trip was spurious.)

- Yes
- No
- Not applicable

Did the system fail** in a dangerous state?:* (That is, the failure did not result in the safe state.)

- Yes
- No
- Not applicable

How long was the operating time before failure (in hours)?:*

Additional information:

** A faulty indicator LED is considered as a cosmetic failure.

MPC4SIL card proof test interval procedure

When a MPC4SIL (safety MPC4) card needs to be returned to Meggitt Switzerland for replacement at the proof test interval, please use the following MPC4SIL card proof test interval procedure.

The MPC4SIL card proof test interval procedure is as follows:

- 1- Complete the **MPC4SIL card proof test interval form** that is available on the following pages.

NOTE: For each MPC4SIL card to be returned for replacement at the proof test interval, a separate MPC4SIL card proof test interval form must be completed and submitted.

NOTE: Please provide as much information as possible in order to help ensure accurate record keeping for MPC4SIL cards and safety-related systems.

It is recommended to keep copies of completed MPC4SIL card proof test interval forms for your own records.

- 2- Send the MPC4SIL card together with a copy of the completed MPC4SIL card proof test interval form by registered post to Meggitt at:

**Repairs department, Meggitt SA, Route de Moncor 4, Case postale,
1701 Fribourg, Switzerland.**

SERVICE AND SUPPORT

Customer feedback

MEGGITT

MPC4SIL card proof test interval form

Contact information

First name:*

Last name:*

Job title:

Company:*

Address:*

Country:*

Email:*

Telephone:*

Fax:

Product information

Product type:*

Part number (PNR):*

Serial number (SER):

Note: Enter "Unknown" if the serial number (SER) is not known.

Meggitt SA purchase order number:

Date of purchase (dd.mm.yyyy):

Site where installed:

End user:



Safety-related system information

Date of installation (commissioning) of the MPC4SIL card in the safety-related system:

Date of previous replacement of MPC4SIL card at the proof test interval (if applicable):

Additional information:

Please provide as much feedback as possible in order to help ensure accurate record keeping for MPC4SIL cards and safety-related systems. Continue on a separate sheet if necessary ...

SERVICE AND SUPPORT

Customer feedback



FEEDBACK

Energy customer feedback form

Manual information

Title of manual:

*VM600 machinery protection system
safety manual*

Reference: MAVM600-FS/E

Version: Edition 8

Date of issue: September 2020

Customer contact information

First name:*

Last name:*

Job title:

Company:*

Address:*

Country:*

Email:*

Telephone:*

Fax:



Feedback – general

Please answer the following questions:

- | | | |
|--|------------------------------|-----------------------------|
| Is the document well organised? | <input type="checkbox"/> Yes | <input type="checkbox"/> No |
| Is the information technically accurate? | <input type="checkbox"/> Yes | <input type="checkbox"/> No |
| Is more technical detail required? | <input type="checkbox"/> Yes | <input type="checkbox"/> No |
| Are the instructions clear and complete? | <input type="checkbox"/> Yes | <input type="checkbox"/> No |
| Are the descriptions easy to understand? | <input type="checkbox"/> Yes | <input type="checkbox"/> No |
| Are the examples and diagrams/photos helpful? | <input type="checkbox"/> Yes | <input type="checkbox"/> No |
| Are there enough examples and diagrams/photos? | <input type="checkbox"/> Yes | <input type="checkbox"/> No |
| Is the style/wording easy to read? | <input type="checkbox"/> Yes | <input type="checkbox"/> No |
| Is any information not included? | <input type="checkbox"/> Yes | <input type="checkbox"/> No |

Please include any additional information in the “Feedback – additional” section below.

Feedback – additional

Additional information:

Please provide as much feedback as possible in order to help us improve our product documentation.
Continue on a separate sheet if necessary ...

SERVICE AND SUPPORT

Customer feedback

MEGGITT

THIS PAGE INTENTIONALLY LEFT BLANK

APPENDIX A: SAFETY CERTIFICATES

The VM600-rack based systems described in this document are certified by TÜV® NORD to the following levels:

- IEC 61508 Safety Integrated Level 1.
- ISO 13849-1 performance level C.

Scanned copies of the safety certificates issued by TÜV NORD are shown on the following pages. Additional information is given in Table A-1.

Table A-1: Index of safety certificates

MPC4 card		Safety certificate	Figure
PNR	Version		
200-510-071-113	Standard MPC4. This is the original “proven-in-use” version.	SLA-0111/09-1, Ver1.0	A-1
200-510-071-311	Safety MPC4 (MPC4SIL). This is the “proven-in-use” version but modified to disable the VME bus interface.	SLA-0052/10-1, Ver1.0	A-2
200-510-077-312	Safety MPC4 (MPC4SIL). This is the “proven-in-use” version with no VME bus interface, but modified to include minor hardware improvements and additional software functions.	SEBS-A. 145124/14, V1.0	A-3
200-510-077-313	Safety MPC4 (MPC4SIL). This is the “proven-in-use” version with no VME bus interface and minor modifications (hardware improvements and additional software functions), further modified to include additional hardware improvements related to RoHS and buffered “raw” outputs.	SEBS-A. 110353/16, V 1.0	A-4



Figure A-1: TÜV NORD certificate SLA-0111/09-1, Ver1.0 for the standard MPC4 card (PNR 200-510-071-113)



Certificate

No. SLA-0052/10-1, Ver. 1.0

TÜV NORD SysTec GmbH & Co. KG hereby certifies

Meggitt SA
Route de Moncor 4
1752 Villars-sur-Glâne
Switzerland

that the safety related

Vibro-Meter - VM600 Machinery Protection System

is capable for safety related applications up to SIL 1 and PL c and meets the requirements listed in the following standards

- IEC 61508: part 1:2010; part 2:2010; capable up to SIL 1
- EN ISO 13849-1:2008; capable up to PL c

The certification is based on the report No. SLA-0052/10TB-1 in the valid version.

This certificate entitles the holder to use the pictured Safety Approved mark.

Expiry date: 2015-11-19
Reference No.: G.SCC.DL.06.027.03.SLA

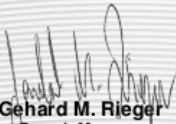
Gerhard M. Rieger
Branch Manager
Augsburg, 2010-11-19



TÜV NORD SysTec GmbH & Co. KG, Branch South, Halderstr. 27, 86150 Augsburg, Germany

Figure A-2: TÜV NORD certificate SLA-0052/10-1, Ver1.0 for the safety MPC4 card (MPC4SIL, PNR 200-510-071-311)

APPENDIX A: SAFETY CERTIFICATES

MEGGITT



Certificate

No. SEBS-A. 145124/14, V1.0

TÜV NORD Systems GmbH & Co. KG hereby certifies to

Meggitt SA
Route de Moncor 4
1752 Villars-sur-Glâne
Switzerland

that the Machinery Protection System
VM600

meets the requirements listed in the below mentioned standards

- IEC 61508:2010, SIL 1
- EN ISO 13849-1:2008, PL c
- EN ISO 13849-2:2012

Base of certification is the report SEBS-A.145124/14TB and the tracking list in the valid version.

This certificate entitles the holder to use the pictured safety approved mark.

Valid until: 2019-11-24
File reference: 8111377449

Hamburg, 2014-11-25

Bianca Puff

Certification Body SEECERT
TÜV NORD Systems GmbH & Co. KG
Große Bahnstraße 31, 22525 Hamburg, Germany



Please note our Test and Certification-Regulation on the back

Figure A-3: TÜV NORD certificate SEBS-A. 145124/14, V1.0 for the safety MPC4 card (MPC4SIL, PNR 200-510-077-312)

MEGGITT

APPENDIX A: SAFETY CERTIFICATES



Certificate

No. SEBS-A.110353/16, V 1.0

TÜV NORD Systems GmbH & Co. KG hereby certifies to

Meggitt Sensing Systems
Route de Moncor 4
1752 Villars-sur-Glâne
Switzerland

that the Machinery Protection System
VM600

is capable for safety related applications and meets the requirements listed in the following standards

- IEC 61508: 2010, SIL 1
- EN ISO 13849-1: 2015, PL c
- EN ISO 13849-2: 2012

The certification is based on the report No. SEBS-A.110353/16TB in the valid version.

This certificate entitles the holder to use the pictured Safety Approved mark.

Expiry date: 2022-09-11
Reference No.: 8113886404

Hamburg, 2017-09-11

B. Puff

Bianca Puff



Certification body SEECERT
TÜV NORD Systems GmbH & Co. KG
Große Bahnstraße 31, 22525 Hamburg, Germany

Figure A-4: TÜV NORD certificate SEBS-A. 110353/16, V 1.0 for the safety MPC4 card (MPC4SIL, PNR 200-510-077-313)

APPENDIX A: SAFETY CERTIFICATES



THIS PAGE INTENTIONALLY LEFT BLANK

CONTACT US & SUPPORT

NEED A QUOTE OR TECHNICAL PARTS REPLACEMENT?

Company: [PLC ProTech Ltd.](#)
Website: www.plcprotech.com
Email: sales@plcprotech.com
Phone: +86 180 4631 7198

Our Service Guarantee:

- 100% Brand New Original & Factory Sealed Components
- 12-Month Quality Warranty on All Industrial Parts
- Worldwide Same-Day Fast Dispatch via DHL / FedEx

[SUBMIT ONLINE RFQ \(REQUEST FOR QUOTE\) >>](#)

[About Us](#) · [Contact](#) · [All Products](#)